

6218A (Seikomatic Weekdater)

1. Specifications

Casing diameter	27.60 mm
Height	5.60 mm
Vibrations per hour	18,000
Automatic winding with sweep second	
Calendar (day and date)	
Second-setting device	

2. Automatic winding mechanism

2-1. Exploded view of automatic winding Fig. 1

2-2. Transmission of force in automatic winding mechanism

This automatic winding mechanism is the most simplified on the market; it consists mainly of the pawl lever and the transmission wheel.

The oscillating weight is rotated by slight movements of the arm, and its rotating torque is transmitted to the pawl lever through the eccentric pin fixed on the ball-bearing.

The pawl lever moves the transmission wheel gears into the ratchet wheel, the mainspring is wound. Fig. 2

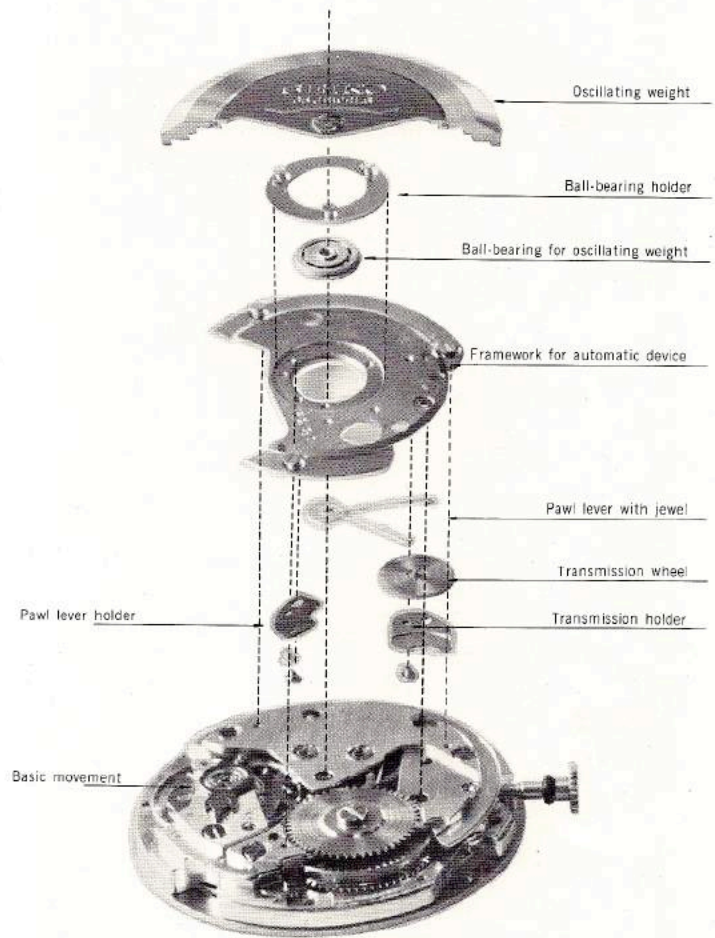

Fig 1

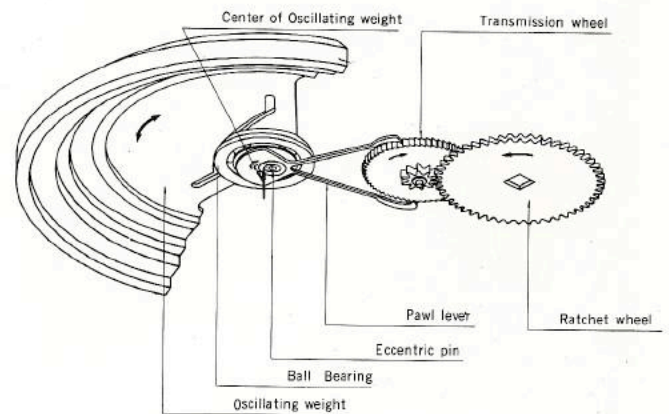

Fig. 2

3. Calendar mechanism

3-1. Exploded view of calendar device

Fig. 3

3-2. Mechanism of calendar device

1) Date driving mechanism

The torque is transmitted as follows:
 Hour wheel → Intermediate date wheel →
 Day & date driving wheel → Date finger →
 Date dial

2) Day driving mechanism

Day & date driving wheel → Day finger
 → Day star with dial disk

Fig. 4

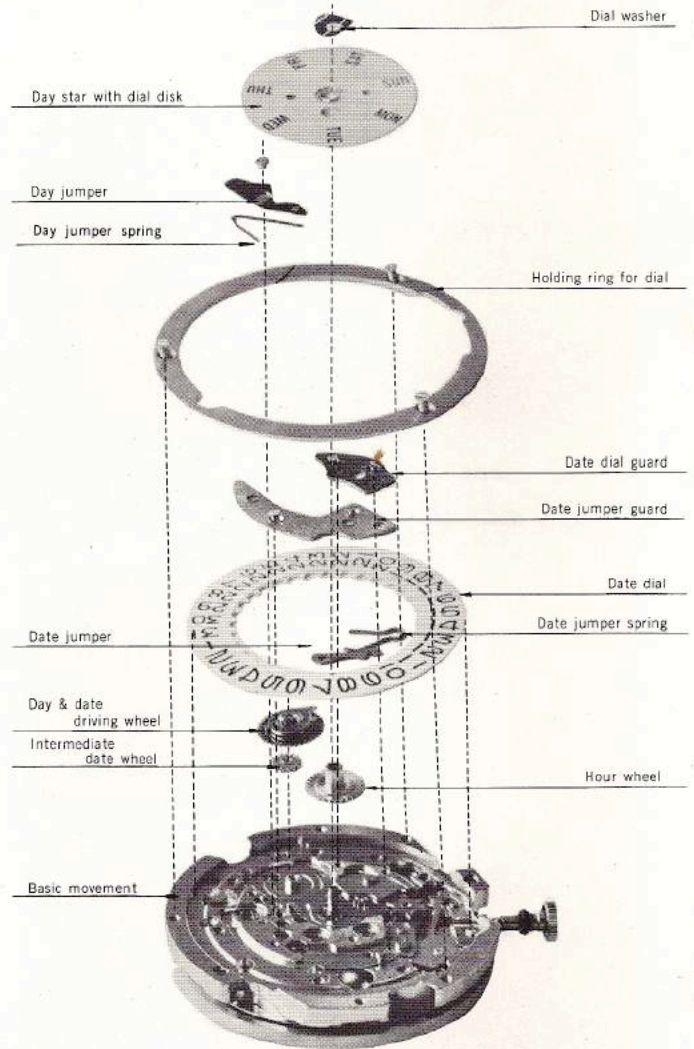

Fig. 3

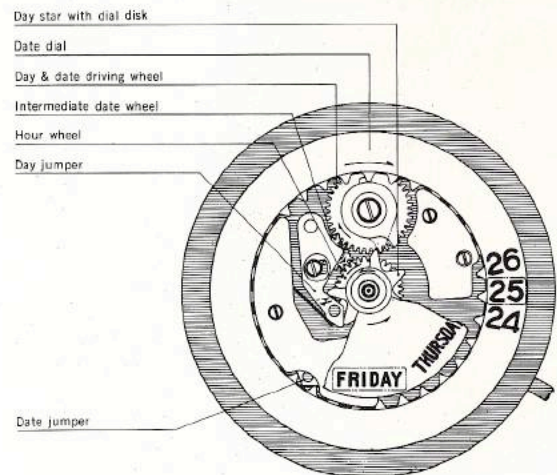

Fig. 4

3-3. Day setting

Pull the crown first to the third position and turn the hands counterclockwise from 1 a.m. to 10 p.m., then turn it clockwise from 10 p.m. to 1 a.m.; repeat until the correct day is shown.

3-4. Date setting

Pull the crown to its second position. Turn clockwise or counterclockwise, advancing or reversing the calendar date.

At the third position set the hands at the desired time.

Return the crown to its original position.

Note: Date setting cannot be done from 8 p.m. to 1 a.m.

4. Second-setting device

When the crown is pulled out to the third position, the sweep second hand stops because the second-setting lever locks the sweep second wheel.

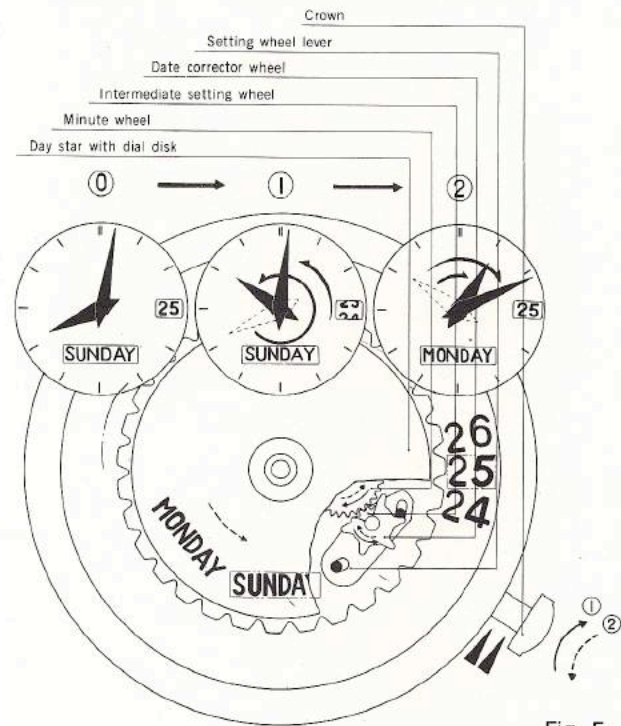

Fig. 5

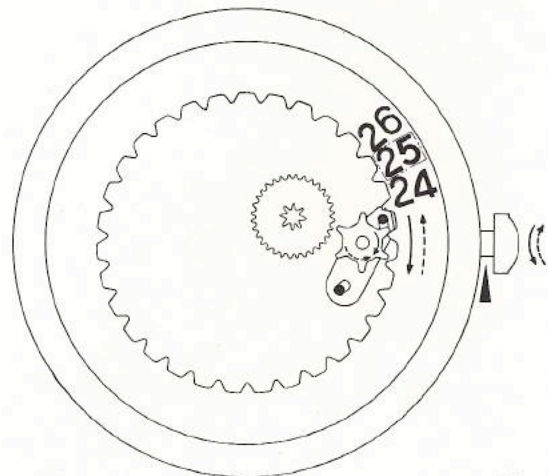

Fig. 6

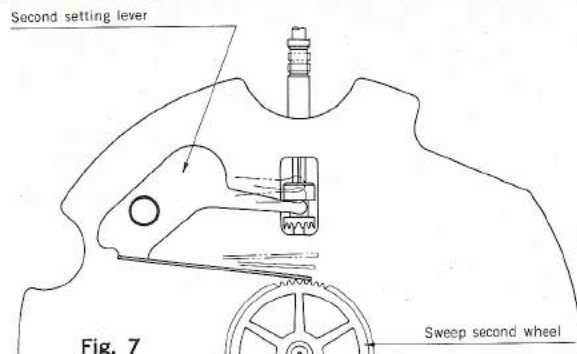

Fig. 7

5. Basic movement

Fig. 8, 9.

6. Disassembly and assembly

See. p. 6218A-5~6218A-13

7. Checking

- (1) Space between hands
- (2) The crown (by working)
- (3) Rotation of hands
- (4) Day and date setting
- (5) Date changes near midnight ; day changes at 1 a.m.
- (6) Positions of hour and minute hands at 12 o'clock
- (7) Second-setting device
- (8) Gasket placement
- (9) Waterproof tests

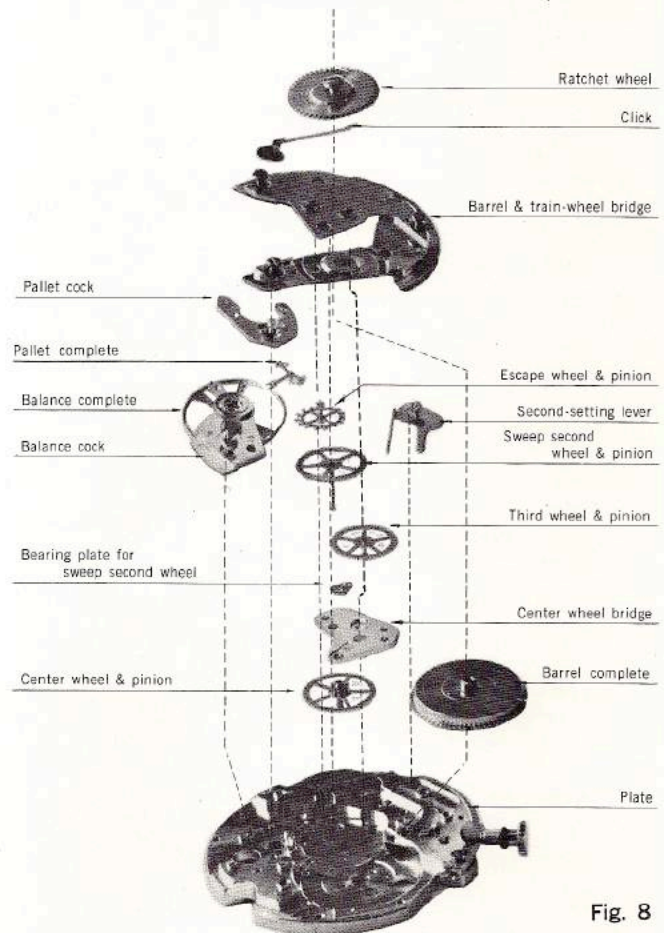

Fig. 8

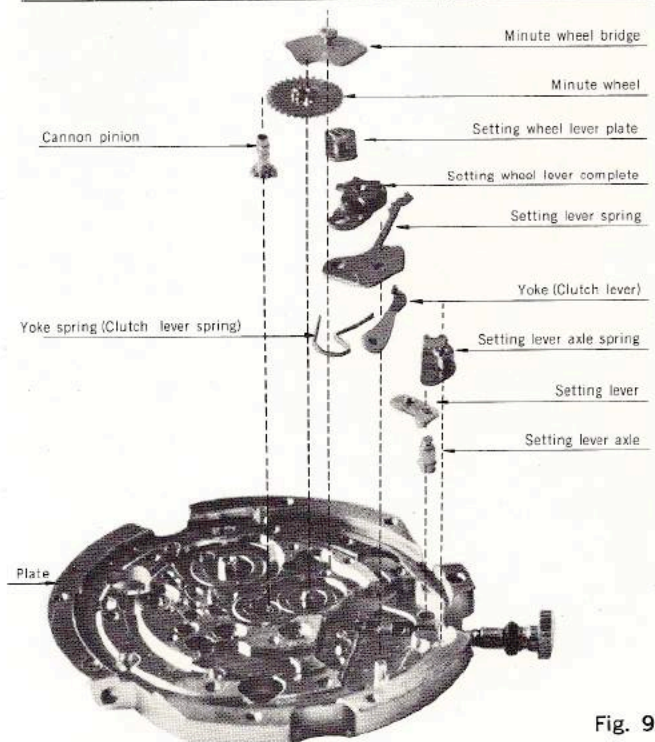
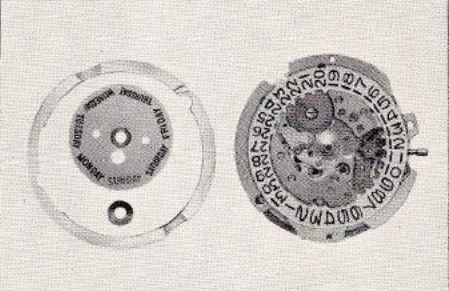
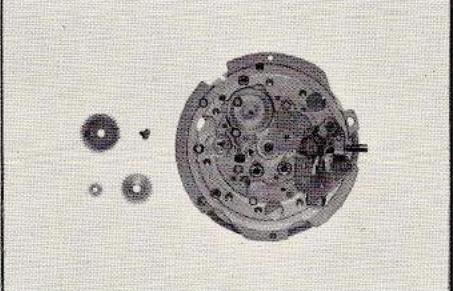
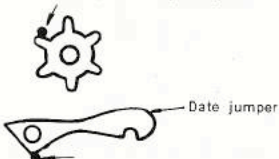
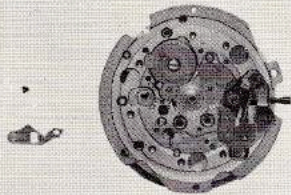

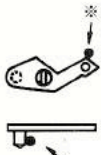

Fig. 9



6218A Disassembly and Assembly—continued

		1 DAY STAR WITH DIAL DISK	2 DATE DIAL
Disassembly	Method	<ol style="list-style-type: none"> 1) Remove holding ring for dial 2) Remove dial washer 3) Remove day star with dial disk 	<ol style="list-style-type: none"> 1) Remove date dial guard 2) Remove date jumper guard (2 screws) 3) Remove day jumper spring from date jumper guard 4) Remove date jumper and its spring 5) Remove date dial
	Remark		Do not immerse date dial into benzine, trichlorethylene, or similar cleaners.
	Photo		
25	INSPECTION	24	23
	Method	<ol style="list-style-type: none"> 1) Insert day jumper spring under date jumper guard 2) Set day star with dial disk 3) Set dial washer 4) Set holding for dial 	<ol style="list-style-type: none"> 1) Lubricate plate under date dial (Moebius Synt-A-Lube) 2) Set date dial 3) Lubricate date jumper (Moebius Synt-A-Lube) 4) Set date jumper and then spring 5) Set date jumper guard and fasten screws (2) 6) Set date dial guard and fasten screws (2) <p>Lubricate only when jumping action is not prompt</p> <p>Lubrication (Moebius Synt-A-Lube)</p>
	Remark		<p>Lubricate date corrector wheel when revolution is not promptly shifted.</p> <div style="text-align: center;">  </div>

6218A Disassembly and Assembly—continued

	3 DAY JUMPER	4 DAY AND DATE DRIVING WHEEL	5
Disassembly	<p>Method</p> <ol style="list-style-type: none"> 1) Loosen day jumper screw 2) Remove day jumper 	<p>Method</p> <ol style="list-style-type: none"> 1) Remove hour wheel 2) Remove intermediate date wheel 3) Remove day & date driving wheel screw 4) Remove day & date driving wheel 	
Remark			
Photo			
Assembly	<p>Method</p> <ol style="list-style-type: none"> 1) Check that day & date driving wheel have proper shake 2) Check that crown can be turned properly *3) Lubricate day jumper *4) Set day jumper and screw Lubricate only when jumping action is not prompt (Moebius Synt-A-Lube) 	<p>Method</p> <ol style="list-style-type: none"> 1) Lubricate pins of day & date driving wheel and intermediate date wheel (Moebius Synt-A-Lube) 2) Set day & date driving wheel 3) Set intermediate date wheel 4) Lubricate cannon pinion (Moebius Synt-A-Lube) 5) Set hour wheel 	
Remark	 <p>*Lubricate only on marked portions when jumping action is not prompt.</p>		

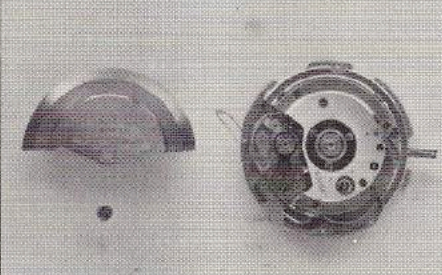
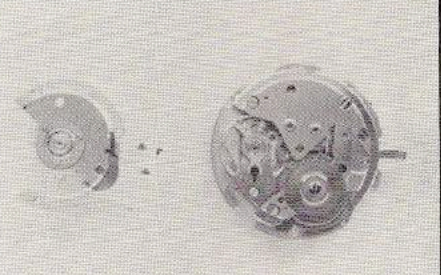
6218A Disassembly and Assembly—continued

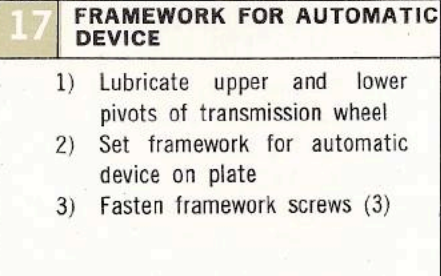
Disassembly	6	OSCILLATING WEIGHT	7	FRAMEWORK FOR AUTOMATIC DEVICE
		<ol style="list-style-type: none"> 1) Remove screw for oscillating weight 2) Remove oscillating weight 		<ol style="list-style-type: none"> 1) Remove screws (3) for framework of automatic device 2) Remove framework for automatic device
		In loosening screw for oscillating weight, press lightly on oscillating weight.		
				
Assembly	19	INSPECTION	18	OSCILLATING WEIGHT
		<ol style="list-style-type: none"> 1) Check position of pawl lever with jewel 2) Check the operation of automatic device 		<ol style="list-style-type: none"> 1) Set oscillating weight 2) Fasten screw for oscillating weight 3) Lubricate upper pivot of transmission wheel and teeth of transmission wheel (watch oil S-4 or Moebius grease "Remontoires")
			Fasten screw thoroughly	
				
				<ol style="list-style-type: none"> 1) Lubricate upper and lower pivots of transmission wheel 2) Set framework for automatic device on plate 3) Fasten framework screws (3)
				Lubrication (watch oil S-4 or Moebius Synt-A-Lube)

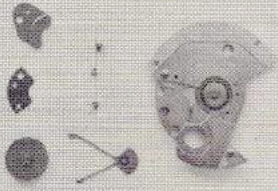
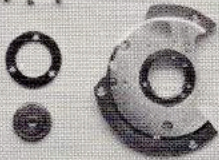
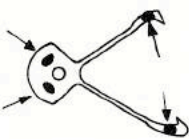
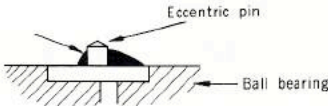

6218A Disassembly and Assembly— *continued*

	8	9	10
Disassembly	TRANSMISSION WHEEL AND PAWL LEVER	BALL BEARING	OUT VIEW INSPECTION OF PARTS
Method	<ol style="list-style-type: none"> 1) Remove transmission holder screw 2) Remove transmission holder 3) Remove pawl lever holder screws (2) 4) Remove pawl lever holder 5) Remove pawl lever and transmission wheel 	<ol style="list-style-type: none"> 1) Remove ball bearing holder screws (3) 2) Remove ball bearing holder 3) Remove ball bearing 	<ol style="list-style-type: none"> 1) Check each part for rust, stain, etc.
Remark	In disengaging teeth of transmission wheel and pawl lever, take care not to deform the shape of pawl lever.	Do not disassemble ball bearing.	
Photo			
Assembly	16	15	
Method	<ol style="list-style-type: none"> 1) Set pawl lever; place pawl lever holder on it, and fasten lever holding screws (2) 2) Lubricate pawl lever 3) Set transmission wheel and transmission holder, and fasten holder screw 	<ol style="list-style-type: none"> 1) Set ball bearing 2) Set ball bearing holder 3) Fasten ball bearing holder screws (3) 4) Lubricate ball bearing 5) Lubricate eccentric pin 	
Remark	Lubrication (watch oil S-4 or Moebius grease "Remontoires") 	6 balls; total to be lubricated; (Moebius Synt-A-Lube) Eccentric pin (watch oil S-4) 	

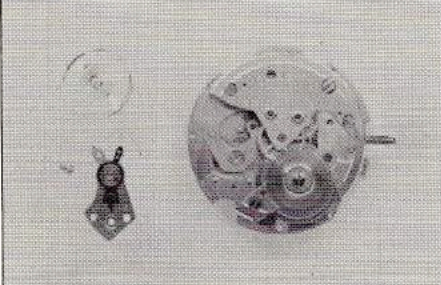

6218A Disassembly and Assembly—*continued*

Disassembly	11	UNWINDING MAINSPRING	12
Method			<ol style="list-style-type: none"> 1) Loosen stud screw 2) Loosen balance cock screw and remove balance cock 3) Turn regulator key and remove balance from cock
Remark			In case balance is removed, take care not to distort the shape of hairspring
Photo			
Assembly	14	LUBRICATION AND INSPECTION OF OUTSIDE APPEARANCE	13
Method	<ol style="list-style-type: none"> 1) Lubricate upper pivot of sweep second wheel pinion (Moebius Synt-A-Lube) 2) To check amplitude, wind mainspring fully and place watch crown down. Amplitude should exceed 180° 	INSPECTION OF BALANCE AND PALLET	12
Remark		<ol style="list-style-type: none"> 1) Check operation of pallet 2) Check the condition of hairspring Unbalance Horizontality 	<ol style="list-style-type: none"> 1) Set balance on balance cock 2) Turn regulator key, so that hairspring is held (in the key) 3) Fasten stud screw, so that stud head is kept above stud holder 4) Set balance cock

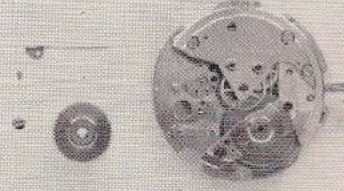

6218A Disassembly and Assembly—continued

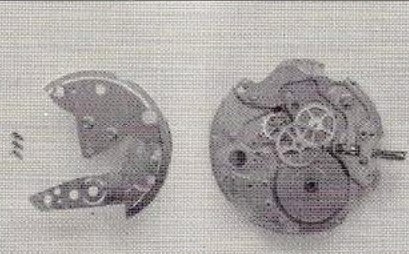
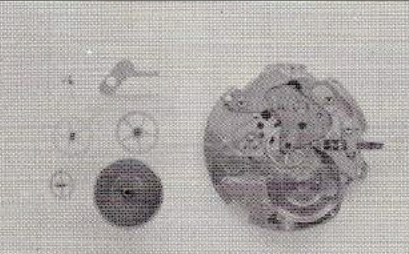
Disassembly	13	DIASHOCK FRAME	14	PALLET COCK	15	RATCHET WHEEL
	<ol style="list-style-type: none"> 1) Remove Diashock springs from plate and balance cock 2) Remove cap jewel & hole jewel with frame and clean by dipping into benzine or trichlorethylene 		<ol style="list-style-type: none"> 1) Remove pallet cock screw 2) Remove pallet cock 3) Remove pallet 		<ol style="list-style-type: none"> 1) Loosen ratchet wheel screw and remove ratchet wheel 2) Loosen click screw and remove click 	
	Use newly opened cleaning liquid Clean thoroughly with a brush.		In removing pallet cock, be careful not to break or bend pallet staff.			
Photo						
Assembly	11	DIASHOCK FRAME	10	PALLET	9	RATCHET WHEEL
	<ol style="list-style-type: none"> 1) Place cap jewel with flat surface upward 2) Put drop of oil on its center, holding cap jewel with tweezers 3) Set Diashock frame with holder jewel directly over oiled cap jewel <p>Lubrication: Moebius (Synt-A-Lube) Dia. of hole jewel Max.: 1/2. Min.: 1/3.</p>		<ol style="list-style-type: none"> 1) Lubricate pallet jewels 2) Set pallet 3) Set pallet cock 4) Fasten pallet cock screw 5) Check that pallet have proper end-shake <p>Lubrication. Pallet jewel (Moebius Synt-A-Lube)</p>		<ol style="list-style-type: none"> 1) Set click 2) Fasten click screw 3) Set ratchet wheel 4) Fasten ratchet wheel screw 	
					Fasten ratchet screw thoroughly.	
Remark						

6218A Disassembly and Assembly—continued

	16	17	18
Disassembly	BARREL AND TRAIN WHEEL BRIDGE	TRAIN WHEELS	MINUTE WHEEL AND CANNON PINION
Method	<ol style="list-style-type: none"> 1) Loosen barrel & train wheel bridge screws (3) 2) Remove barrel & train wheel bridge 	<ol style="list-style-type: none"> 1) Loosen second setting lever screw and remove second setting lever 2) Remove sweep second wheel & pinion, third wheel & pinion, escape wheel & pinion, and barrel complete 	<ol style="list-style-type: none"> 1) Remove cannon pinion 2) Loosen and remove minute wheel bridge screw 3) Remove minute wheel bridge and minute wheel
Remark			
Photo			
Assembly	8	7	6
Method	<ol style="list-style-type: none"> 1) Set barrel & train wheel bridge 2) Insert pivots into hole jewels 3) Fasten barrel & train wheel bridge screws (3) 4) Check proper end-shakes 	<ol style="list-style-type: none"> 1) Lubricate barrel arbor 2) Set barrel 3) Set escape wheel & pinion 4) Set third wheel & pinion 5) Lubricate sweep second wheel & pinion (Moebius Synt-A-Lube) 6) Set sweep second wheel & pinion 7) Set second-setting lever 8) Fasten second-setting lever screw 	<ol style="list-style-type: none"> 1) Lubricate minute wheel pin (Moebius Synt-A-Lube) 2) Set minute wheel and minute wheel bridge 3) Fasten minute wheel bridge screw 4) Set cannon pinion
Remark	<p>Check wheel rotation. Check space between wheels. Check the second-setting.</p>	<p>Lubricate barrel arbor (Moebius grease "Remontoires" or watch oil S-4).</p>	

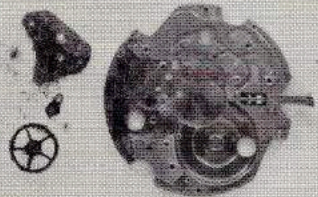
6218A Disassembly and Assembly—continued

Disassembly	19	CENTER WHEEL BRIDGE	20	SETTING WHEEL LEVER COMPLETE	21	WINDING STEM
	<ol style="list-style-type: none"> 1) Loosen and remove center wheel bridge screw 2) Remove center wheel bridge and the center wheel & pinion 		<ol style="list-style-type: none"> 1) Loosen setting lever spring screw 2) Remove setting wheel lever plate, setting wheel lever complete, setting lever spring, clutch lever spring, and clutch lever 		<ol style="list-style-type: none"> 1) Loosen screw for setting lever axle spring and remove setting lever axle spring, setting lever, and setting lever axle 2) Remove winding stem and clutch wheel 	
	Remark		Remark		Remark	
Assembly						
	5	CENTER WHEEL BRIDGE	4	SETTING WHEEL LEVER COMPLETE	3	WINDING STEM
	<ol style="list-style-type: none"> 1) Lubricate center wheel pinion 2) Set center wheel & pinion 3) Set center wheel bridge 4) Fasten center wheel bridge screw 		<p>Lubricate setting wheel lever complete (Moebius Synt-A-Lube)</p> <ol style="list-style-type: none"> 1) Set clutch lever 2) Set clutch lever spring 3) Lubricate pin of setting wheel (watch oil S-4) 4) Set setting wheel lever complete 5) Set setting lever spring 6) Set setting wheel lever plate 7) Fasten setting lever spring screw 8) Lubricate clutch lever pin with watch oil S-4 		<ol style="list-style-type: none"> 1) Set clutch wheel and winding stem 2) Set setting lever axle and setting lever 3) Set setting lever axle spring and fasten screw 	
Remark		Remark		Remark		

6218A Disassembly and Assembly—*continued*

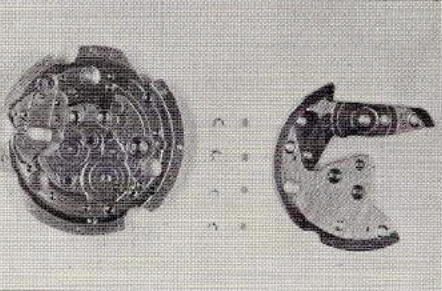
Disassembly	21	DIAFIX	22	CLEANING
	<ol style="list-style-type: none"> 1) Remove Diafix springs from barrel & train wheel bridge and plate 2) Remove cap jewels 3) Clean them in benzine or trichlorethylene 		<ol style="list-style-type: none"> 1) Clean all disassembled parts (refer to CLEANING for further details) 	
Remark				
Photo				
Assembly	2	DIAFIX	1	LUBRICATION
	<ol style="list-style-type: none"> 1) Insert cap jewels into Diafix frames of plate and barrel & train wheel bridge 2) Set Diafix springs 3) Lubricate them (Moebius Synt-A-Lube) Dia. of hole jewel max.: 1/2 min.: 1/3 		<ol style="list-style-type: none"> 1) Lubricate winding stem, clutch wheel, and setting lever (head of axle) (watch oil S-4 or Moebius grease "Remontoires") 	
Remark				