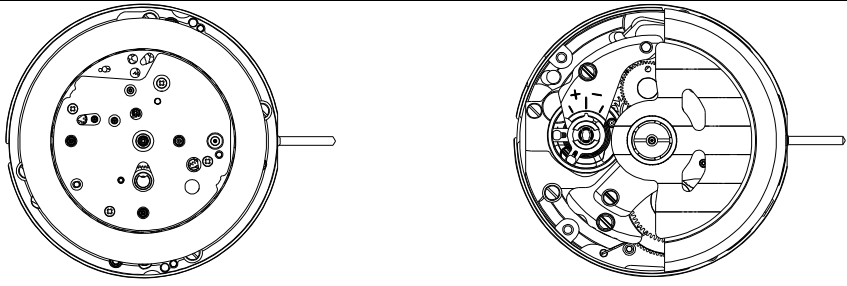

**TECHNICAL GUIDE
&
PARTS CATALOGUE**

CaI.NE86

AUTOMATIC MECHANICAL

SII Products

Item		Cal. Code	NE86	
Movement				
Movement size	Outside diameter	Φ28.60mm		
	Casing diameter	Φ28.00mm		
	Total height	7.62mm		
Time indication		2 Hands (Hour , Minute) Small Second hand / 3 o'clock Date Calendar Chronograph 60 seconds counter / Center 30 minutes counter / 9 o'clock		
Basic function		Manual winding Automatic winding with ball bearing Stop second device Quick date correction		
Frequency		28,800 vibrations per hour		
Accuracy	Static accuracy	-15~+25 seconds per day * Measurement should be done within 10~60 minutes after fully wound up. * All measurements are made without the calendar in function. * All measurements are made without the chronograph in function.		
	Measurement position	Direction of 3 positions. (1) Dial up (2) 9 o'clock up (3) 6 o'clock up		
	Lift angle	51 deg.		
	Measurement time	20 seconds * Equipment to be used : Witschi WATCH EXPERT		
	Posture difference	Difference is under 45 seconds within max value and min. value. * Measurement should be done within 10~60 minutes after fully wound up. * Direction of 4 positions. (1) 12 o'clock up (2) 9 o'clock up (3) 6 o'clock up (4) 3 o'clock up		
	Isochronisms (24h-0h)	-10~+20 seconds per day. * Direction of position. : Dial up * Difference of static accuracy of 24h and 0h		
Duration time		More than 45 hours ... Mainspring after fully wound up. * Posture to confirmation : Dial up * Measurements are made without the chronograph in function.		
Winding the mainspring		<< Movement >> • Fully wound up by turning the crown minimum 55 times. • Fully wound up by turning the ratchet wheel screw 8 times. << Complete Watch >> A winding machine is needed to wind up the mainspring. Full wind up conditions • Rotary speed : 30 rpm • Operating time: 60 minutes		
Jewels		34 jewels		
Crown position		Counterclockwise		Clockwise
	Normal position	Free		Manual winding
	First click	Date setting		Free
	Second click	Time setting		Time setting
Button position	2 o'clock	Chronograph Start & Stop		
	4 o'clock	Chronograph Reset		

Disassembling procedures Figs. ① ⇒ ⑨③

Reassembling procedures Figs. ⑨③ ⇒ ①

Type of oil



Oil quantity mark

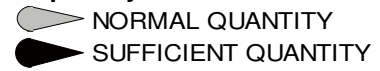

[NOTE]

**Some parts cannot move when the chronograph is at RESET position.
Please press button A to START the chronograph before assembly / disassembly.**

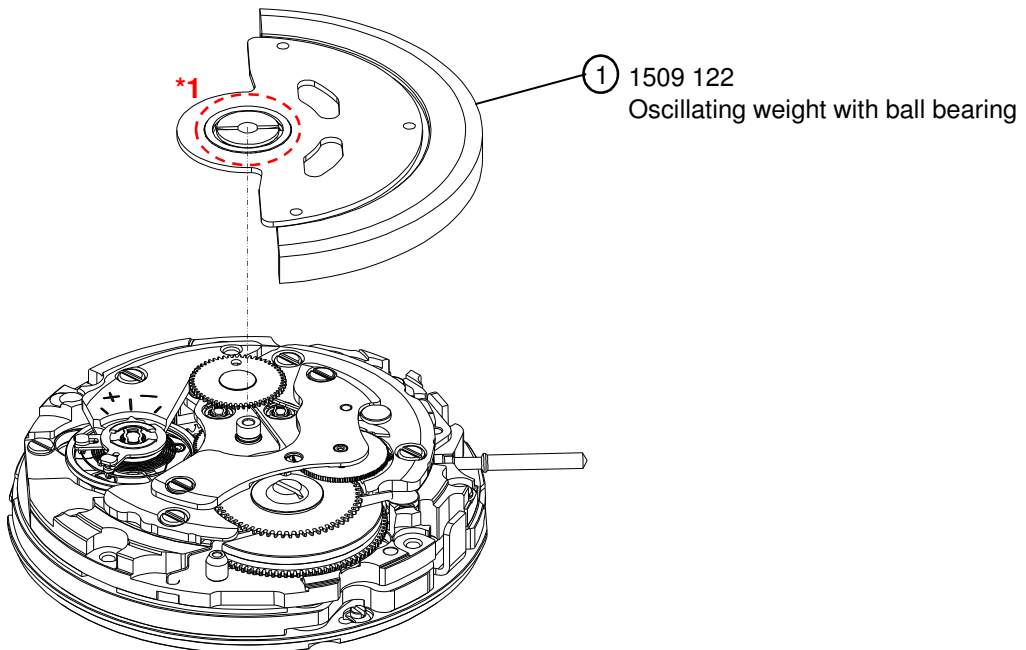
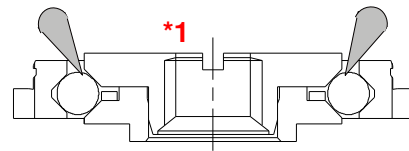
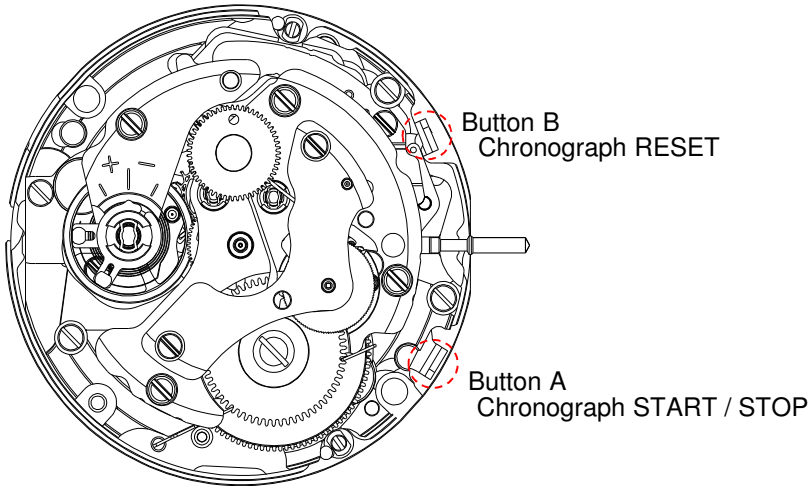

Type of oil		Oil quantity mark	
	Moebius 9010		NORMAL QUANTITY
	S-6		SUFFICIENT QUANTITY
	S-4		

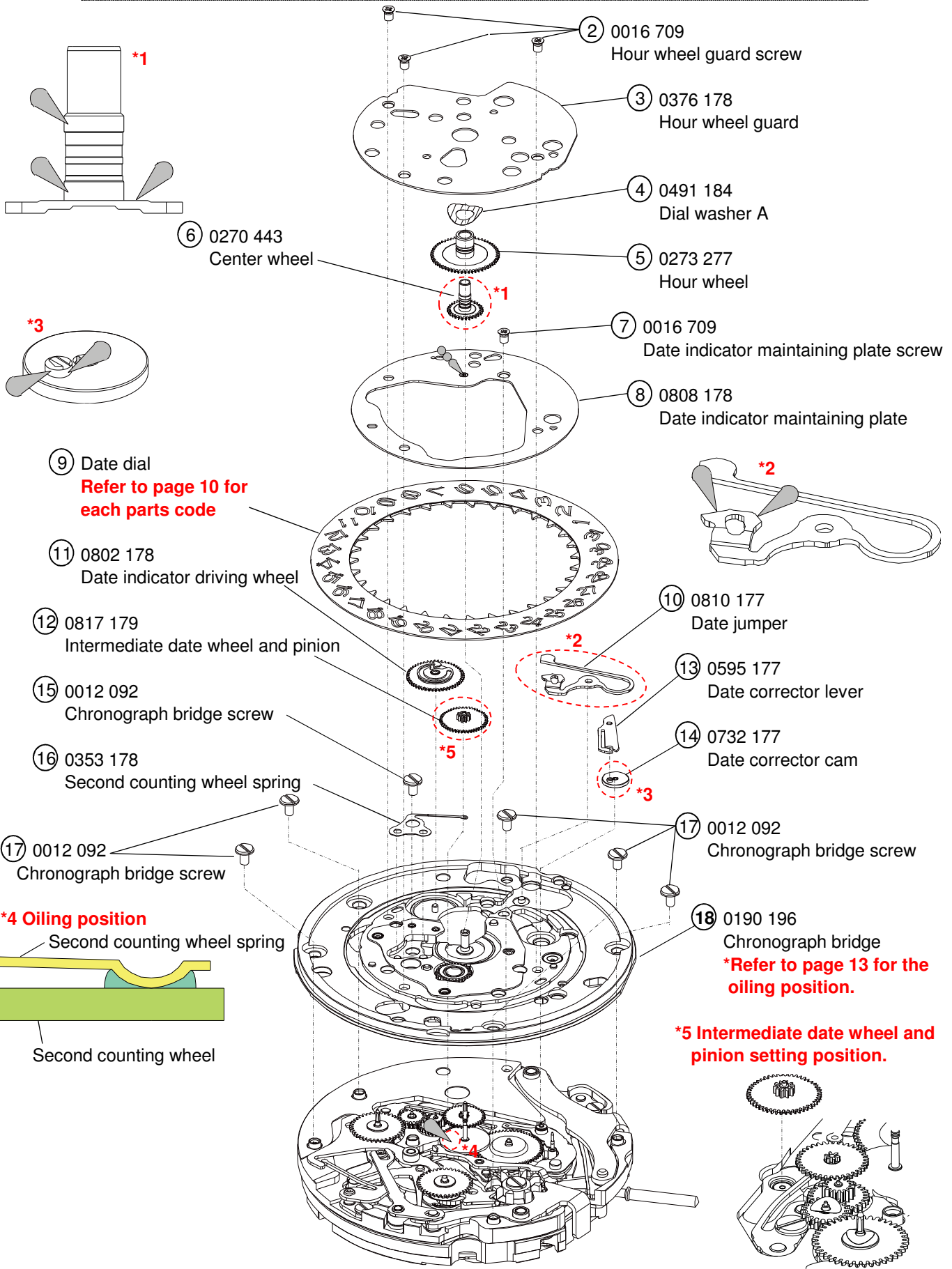

Type of oil

Moebius 9010

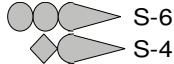

Oil quantity mark

NORMAL QUANTITY

SUFFICIENT QUANTITY

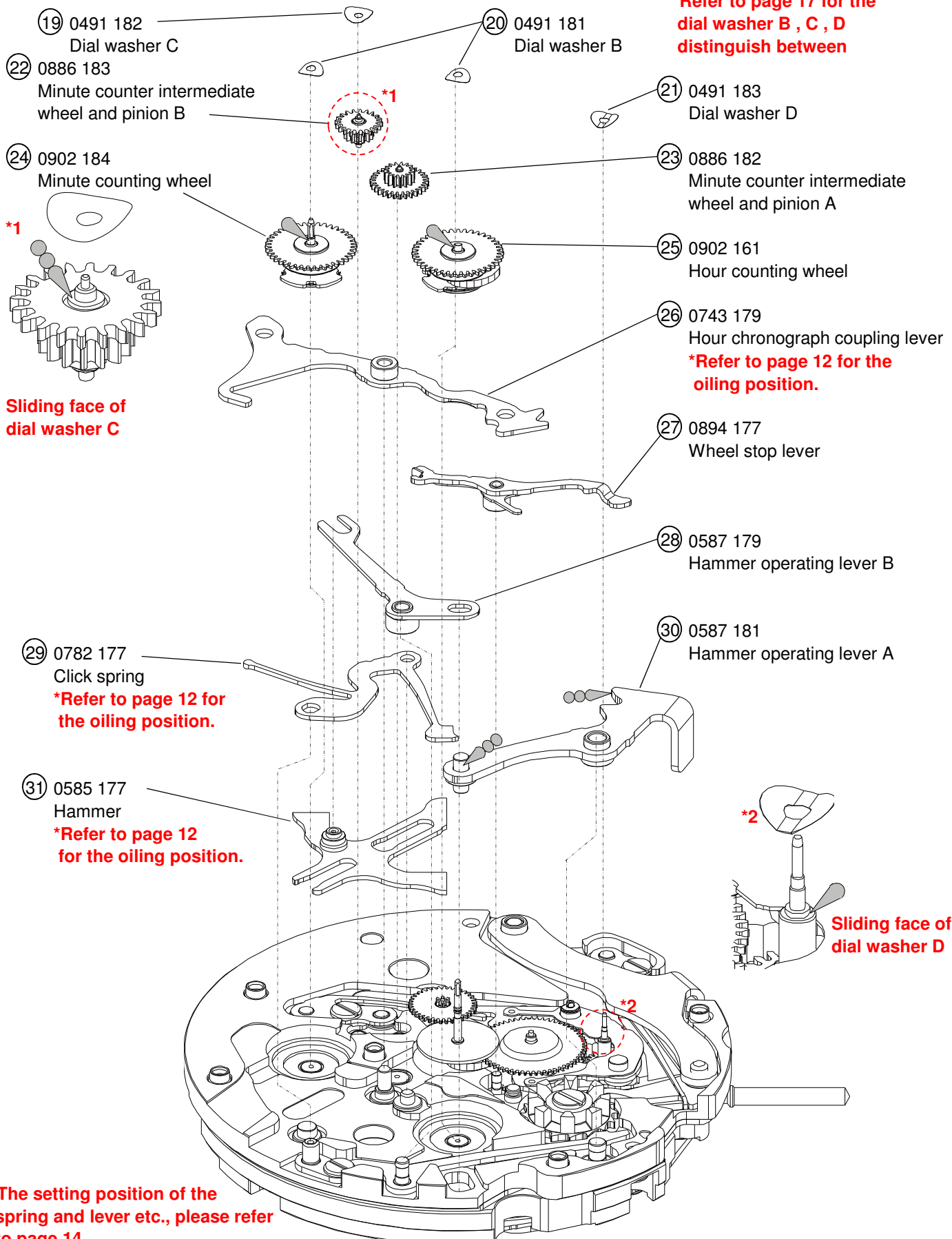





***Refer to page 17 for the dial washer B, C, D distinguish between**

***Refer to page 12 for the oiling position.**

***Refer to page 12 for the oiling position.**

***Refer to page 12 for the oiling position.**

***The setting position of the spring and lever etc., please refer to page 14.**

Type of oil		Oil quantity mark	
	Moebius 9010		NORMAL QUANTITY
	S-6		SUFFICIENT QUANTITY
	S-4		

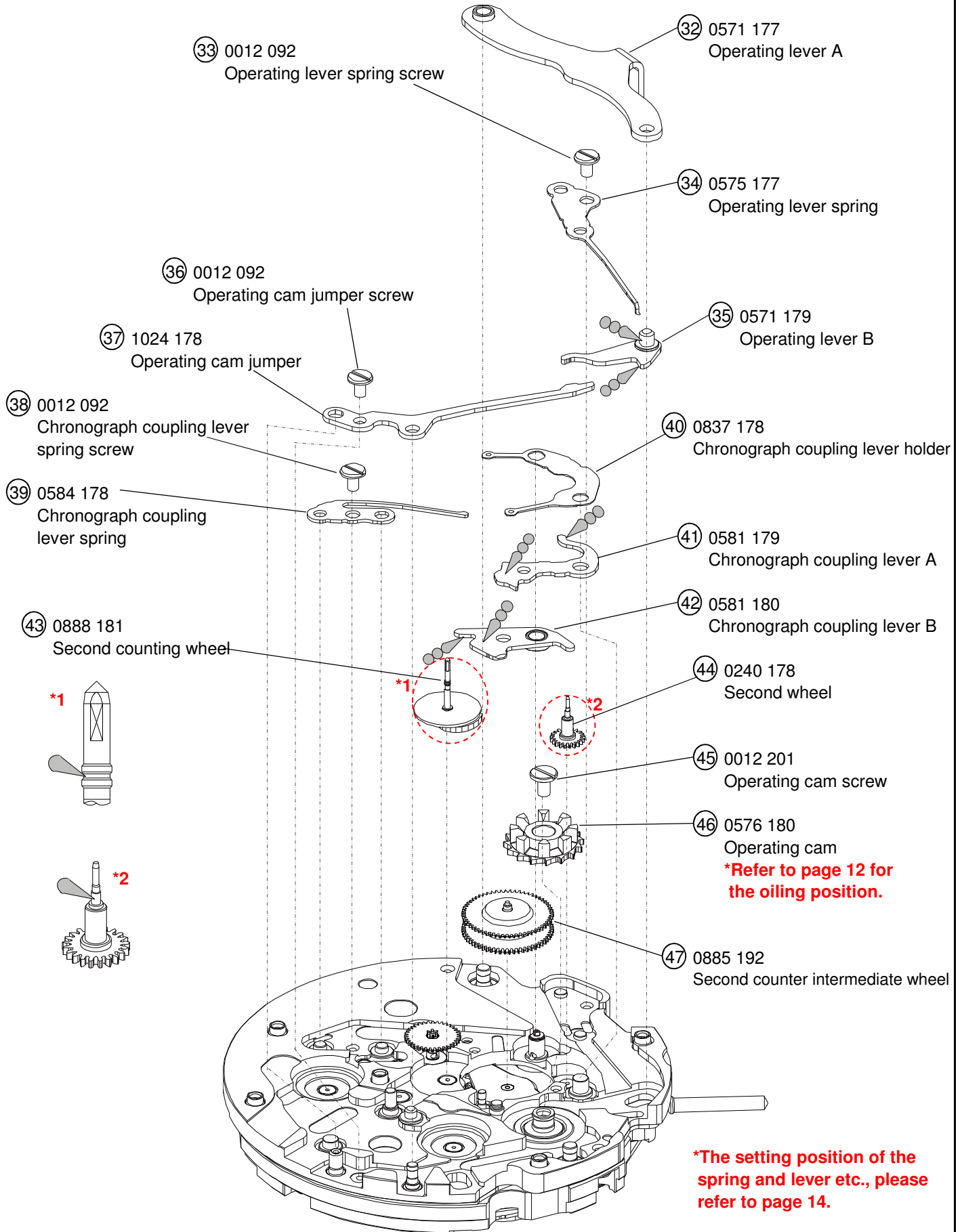

***The setting position of the spring and lever etc., please refer to page 14.**

Type of oil

Moebius 9010

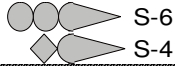

Oil quantity mark

NORMAL QUANTITY

SUFFICIENT QUANTITY

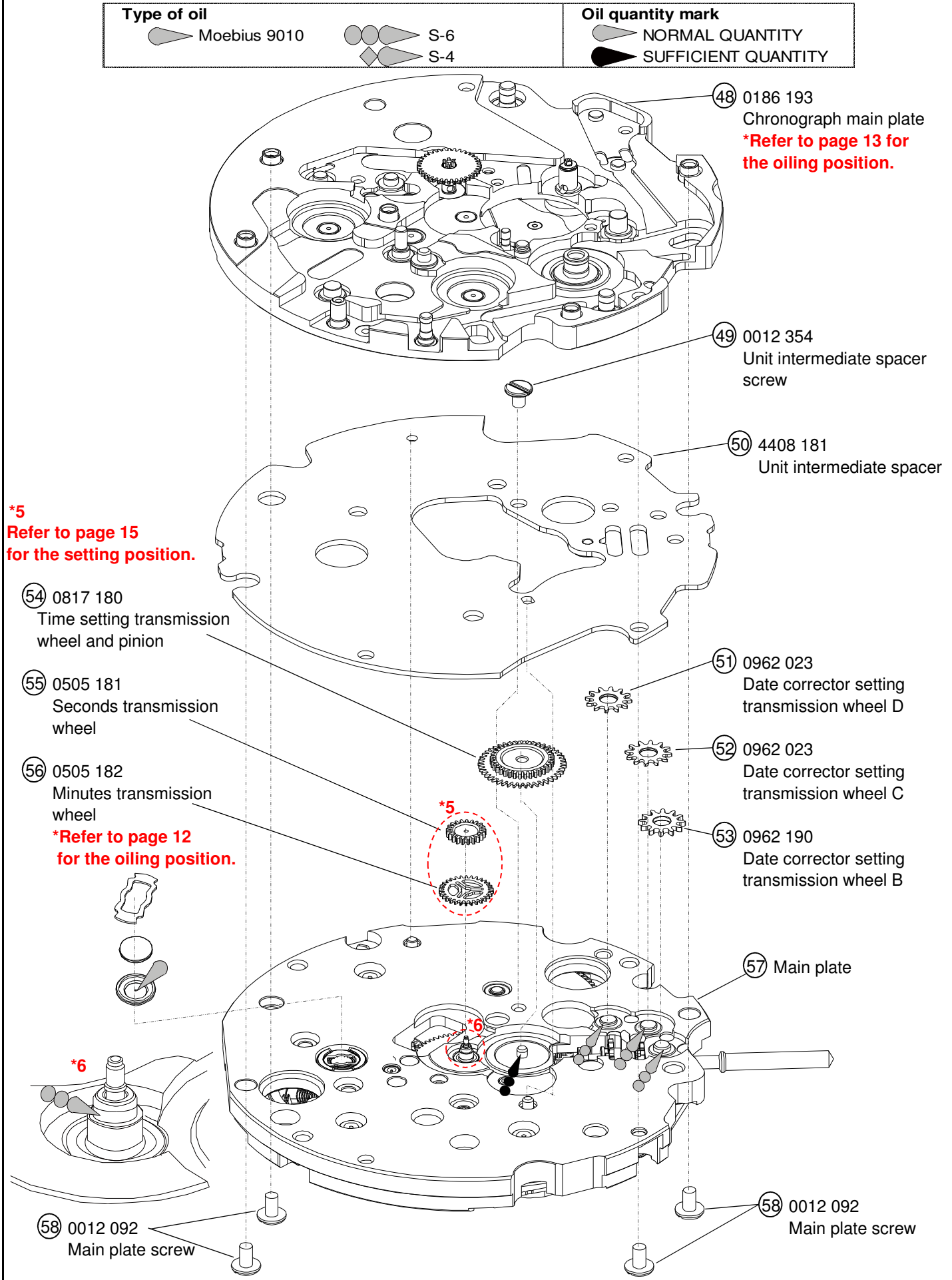

***5**
Refer to page 15
for the setting position.

48 0186 193
Chronograph main plate
***Refer to page 13 for
the oiling position.**

49 0012 354
Unit intermediate spacer
screw

50 4408 181
Unit intermediate spacer

54 0817 180
Time setting transmission
wheel and pinion

55 0505 181
Seconds transmission
wheel

56 0505 182
Minutes transmission
wheel
***Refer to page 12
for the oiling position.**

51 0962 023
Date corrector setting
transmission wheel D

52 0962 023
Date corrector setting
transmission wheel C

53 0962 190
Date corrector setting
transmission wheel B

57 Main plate

58 0012 092
Main plate screw

58 0012 092
Main plate screw

Type of oil

Moebius 9010





S-6
S-4

Oil quantity mark

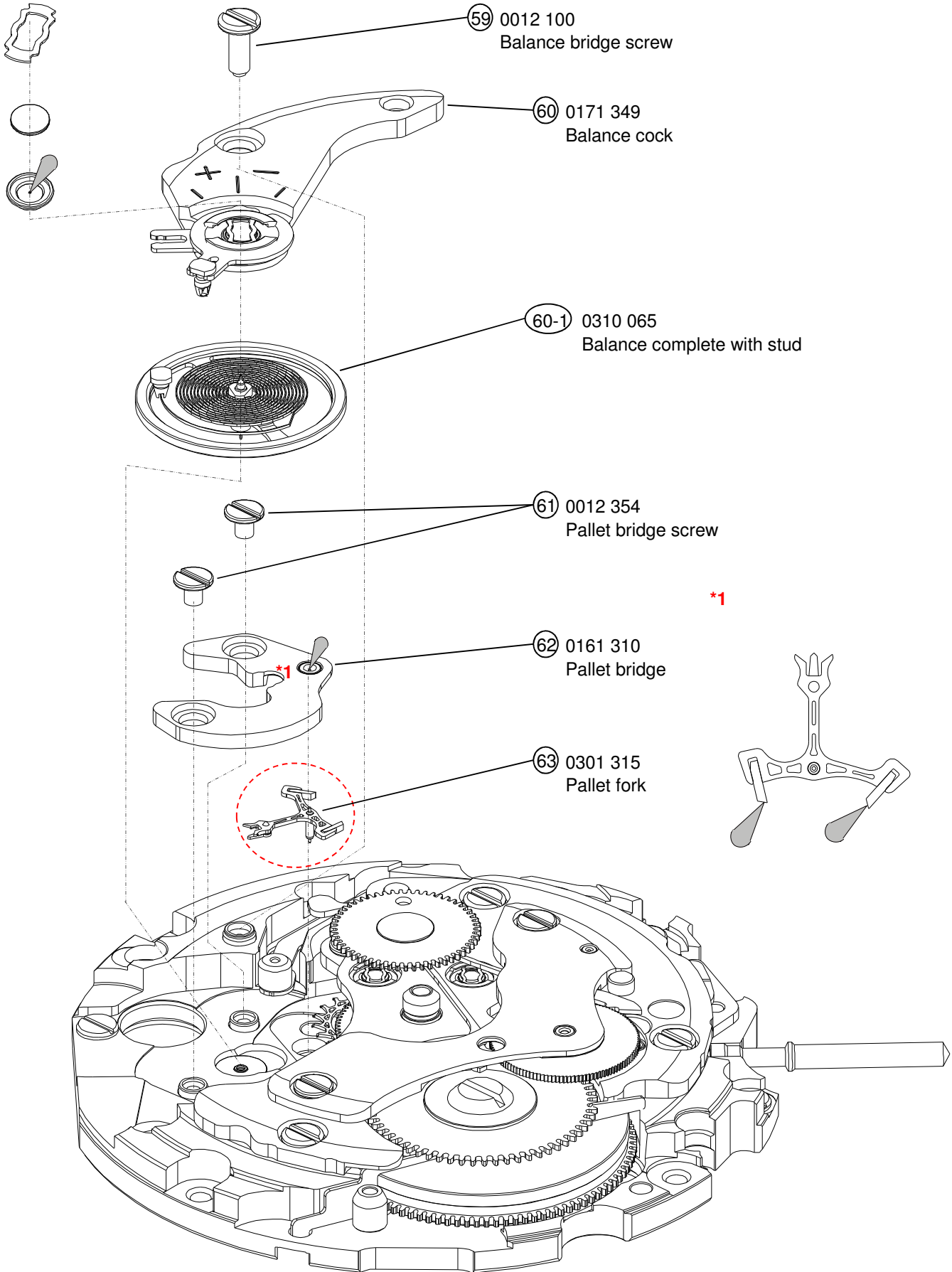
NORMAL QUANTITY

SUFFICIENT QUANTITY



Type of oil		Oil quantity mark	
	Moebius 9010		NORMAL QUANTITY
	S-6		SUFFICIENT QUANTITY
	S-4		

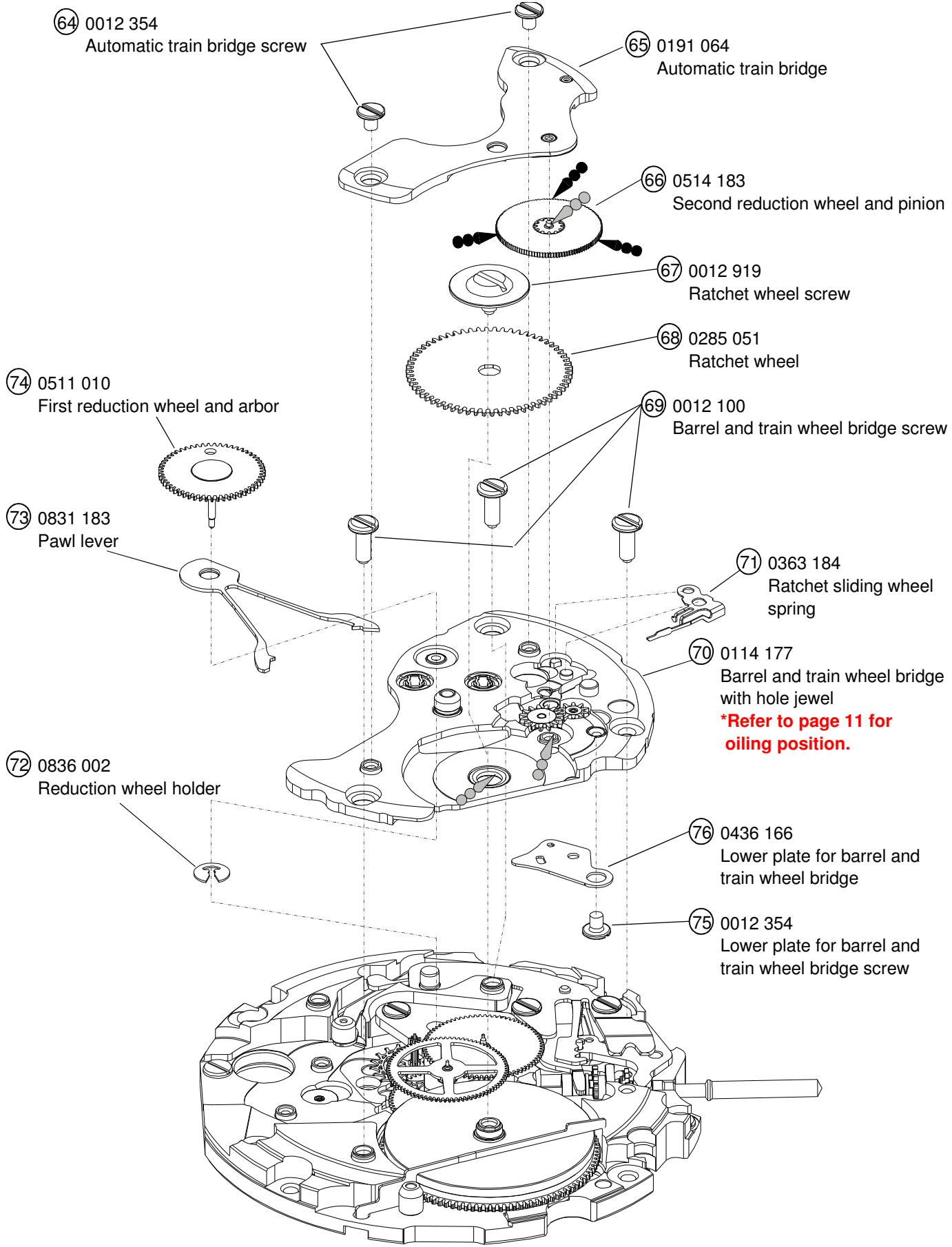

Type of oil

Moebius 9010

S-6
S-4



Oil quantity mark

NORMAL QUANTITY

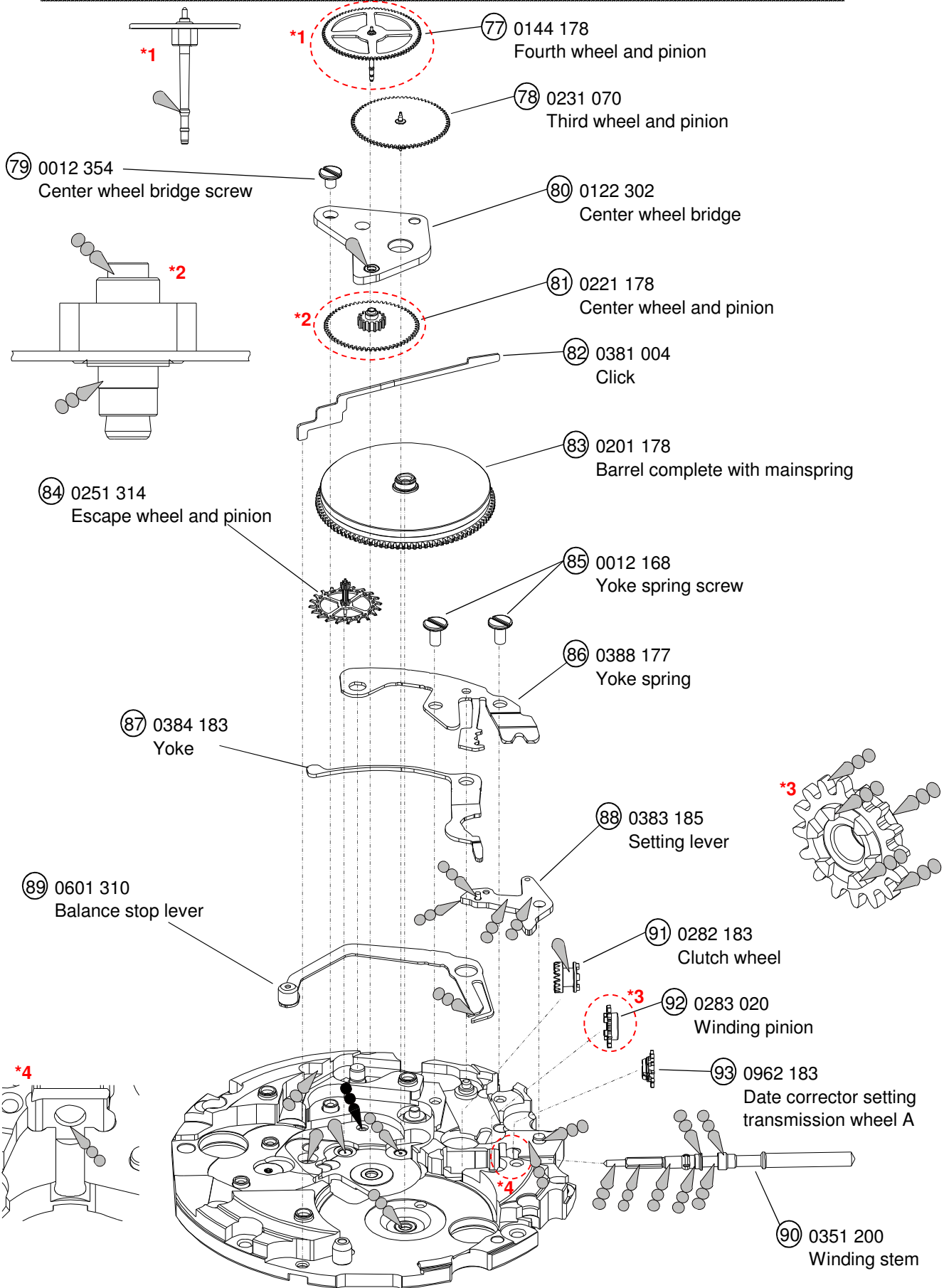
SUFFICIENT QUANTITY



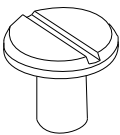
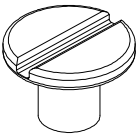
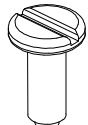
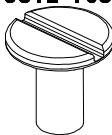
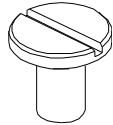
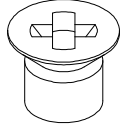



● List of screw

Parts code	Parts name	Parts code	Parts name	Parts code	Parts name
0012 092 	⑮ Second counting wheel spring screw	0012 354 	④⑨ Unit intermediate spacer screw	0012 100 	⑤⑨ Balance bridge screw
	⑰ Chronograph bridge screw (x5)		⑥① Pallet bridge screw (x2)		⑥⑨ Barrel and train wheel bridge screw (x3)
	③③ Operation lever spring screw		⑥④ Automatic train bridge screw (x2)	0012 168 	⑧⑤ Yoke spring screw (x2)
	③⑥ Operation cam jumper screw		⑦⑤ Lower plate for barrel and train wheel bridge screw		
	③⑧ Chronograph coupling lever spring screw		⑦⑨ Center wheel bridge screw		
	⑤⑧ Main plate screw (x4)		0012 201 	④⑤ Operating cam screw	0016 709 
0012 919 	⑥⑦ Ratchet wheel screw	⑦ Date indicator maintaining plate screw			

⑨ Date dial

Parts code	Position of crown	Position of date frame	Color of numbers	Color of background
0878 109	3H	3H	Black	Silver (Plain metal)
0878 108	3H	3H	White	Black

*All parts code are subject to change without notice.

Type of oil		Oil quantity mark	
 Moebius 9010	 S-6	 NORMAL QUANTITY	 SUFFICIENT QUANTITY
	 S-4		

1.Oiling spot

(1) **70** Barrel and train wheel bridge with hole jewel

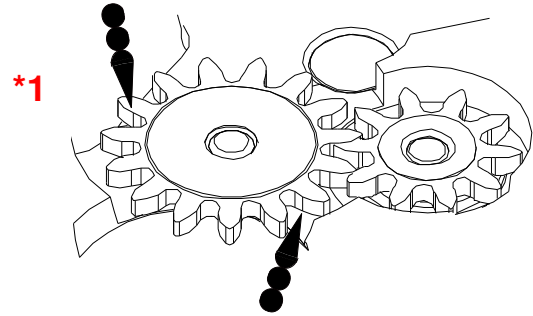
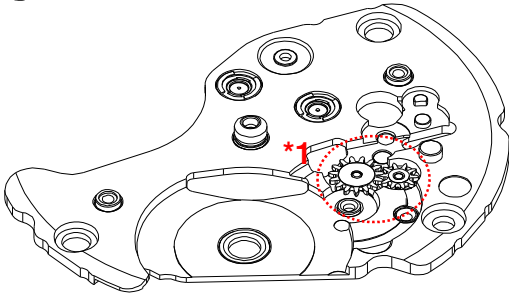

Barrel and train wheel bridge with hole jewel (back side)

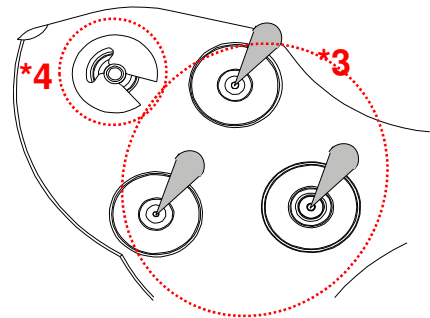
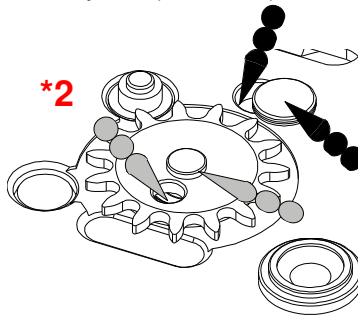
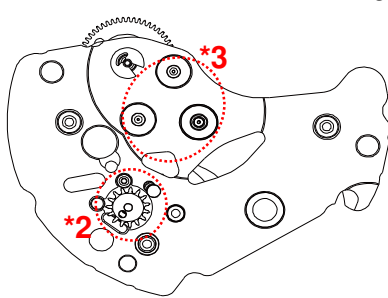

Note

***2** After oiling, set lower plate for barrel and train wheel bridge & screw.

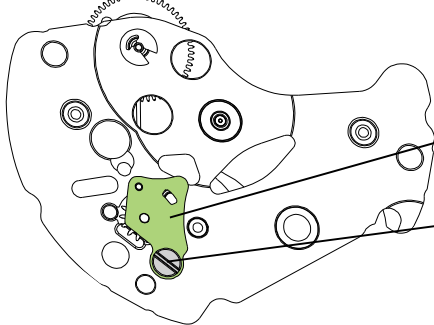

76 Lower plate for barrel and train wheel bridge

75 Lower plate for barrel and train wheel bridge screw

***4** After oiling, set first reduction wheel and arbor & pawl lever & reduction wheel holder.

74 First reduction wheel and arbor

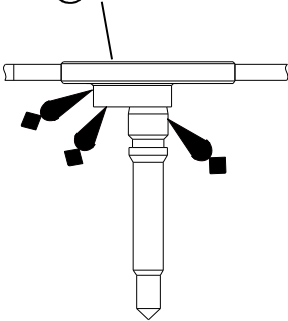

74 First reduction wheel and arbor

73 Pawl lever

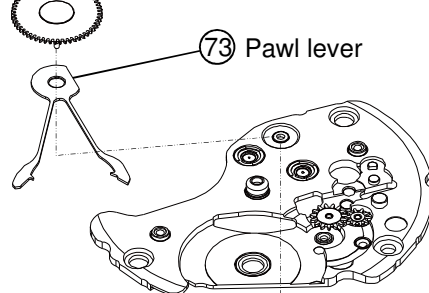

72 Reduction wheel holder

Note

***Refer to the page 16 for disassembling and reassembling.**

Type of oil		Oil quantity mark
Moebius 9010		NORMAL QUANTITY
	S-6	SUFFICIENT QUANTITY
	S-4	

1.Oiling spot

(2) (46) Operating cam

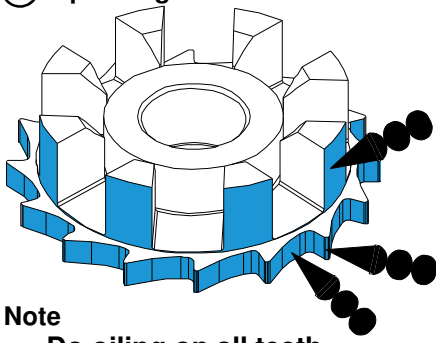

Note
Do oiling on all teeth

(3) (31) Hammer

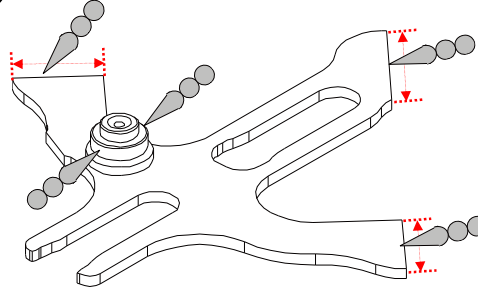

Note
There must be oil within the range of the arrow.

(4) (26) Hour chronograph coupling lever

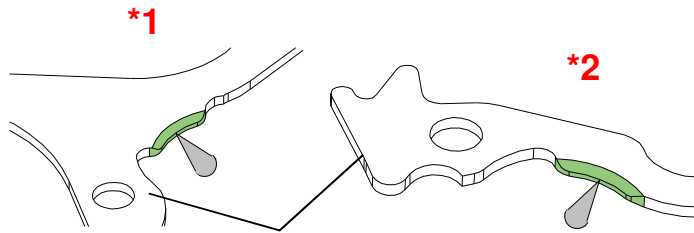
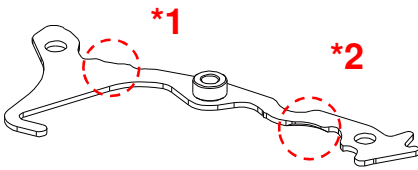

Back side

(5) (29) Click spring

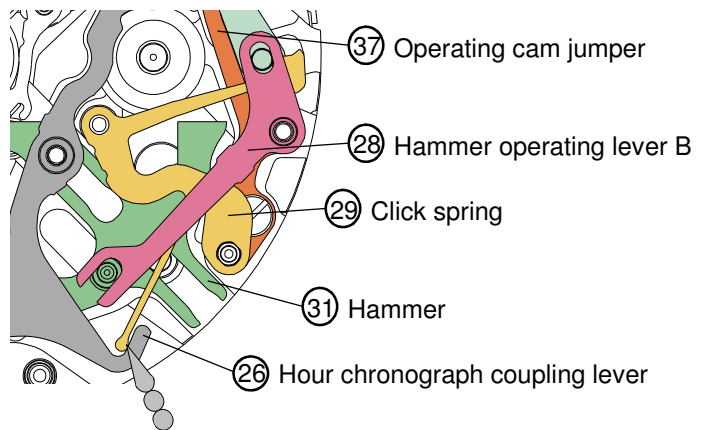
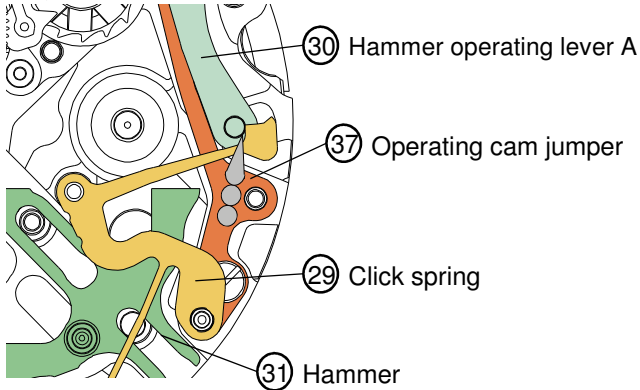

Note
There must be oil within the range of the arrow.

(6) (56) Minutes transmission wheel

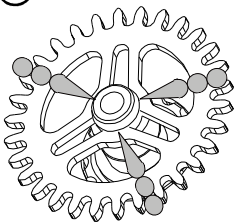

Type of oil

Moebius 9010

S-6
S-4

Oil quantity mark

NORMAL QUANTITY

SUFFICIENT QUANTITY

1.Oiling spot

(7) **48** Chronograph main plate

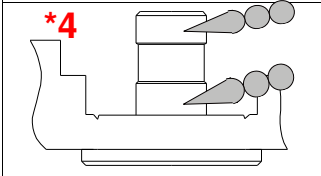
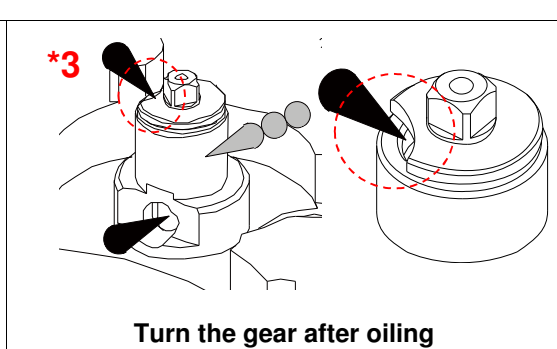
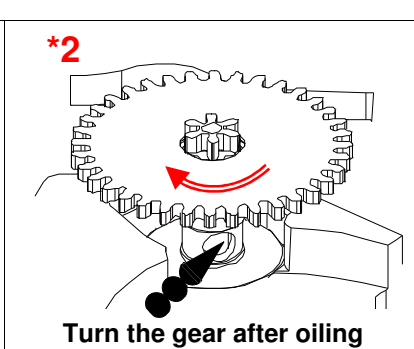
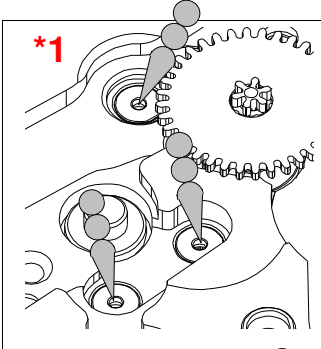
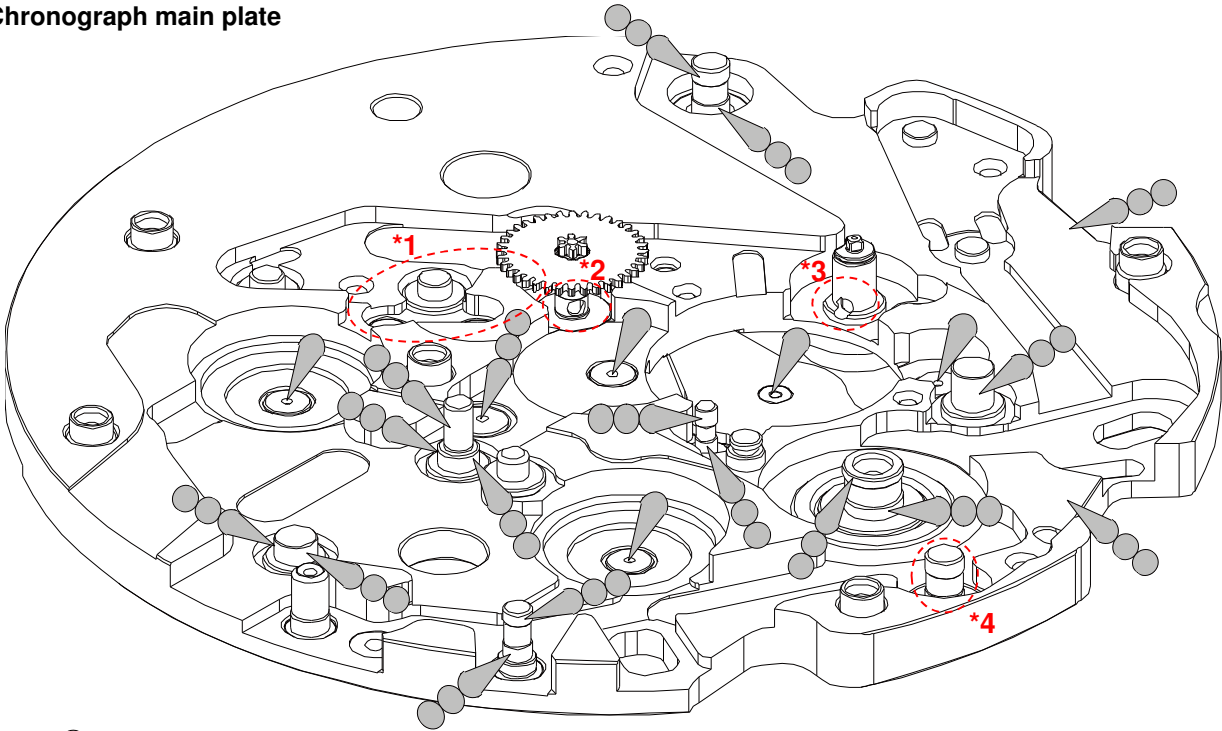

Note

There must be oil within the range of the arrow.

(8) **18** Chronograph bridge

[Front side]

[Back side]

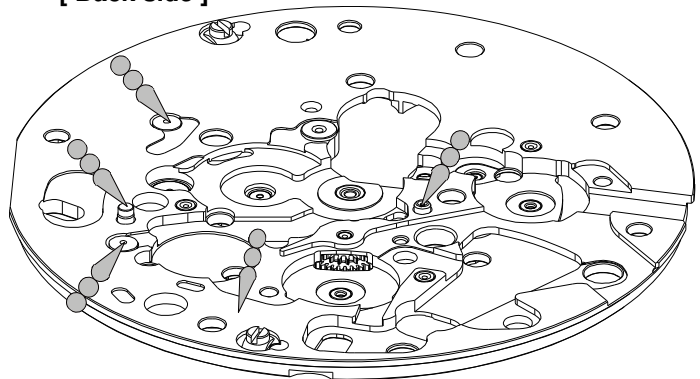
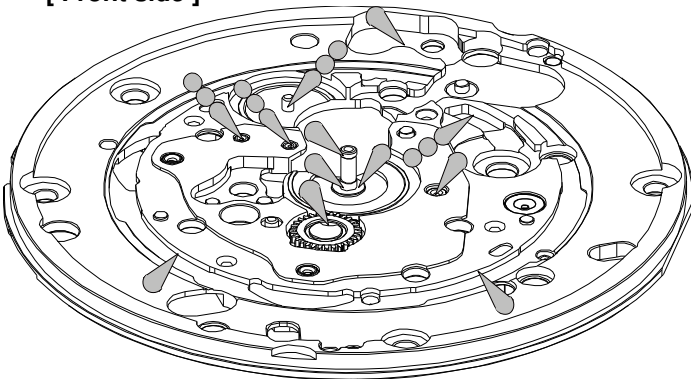

2.The setting position of the spring and lever etc.

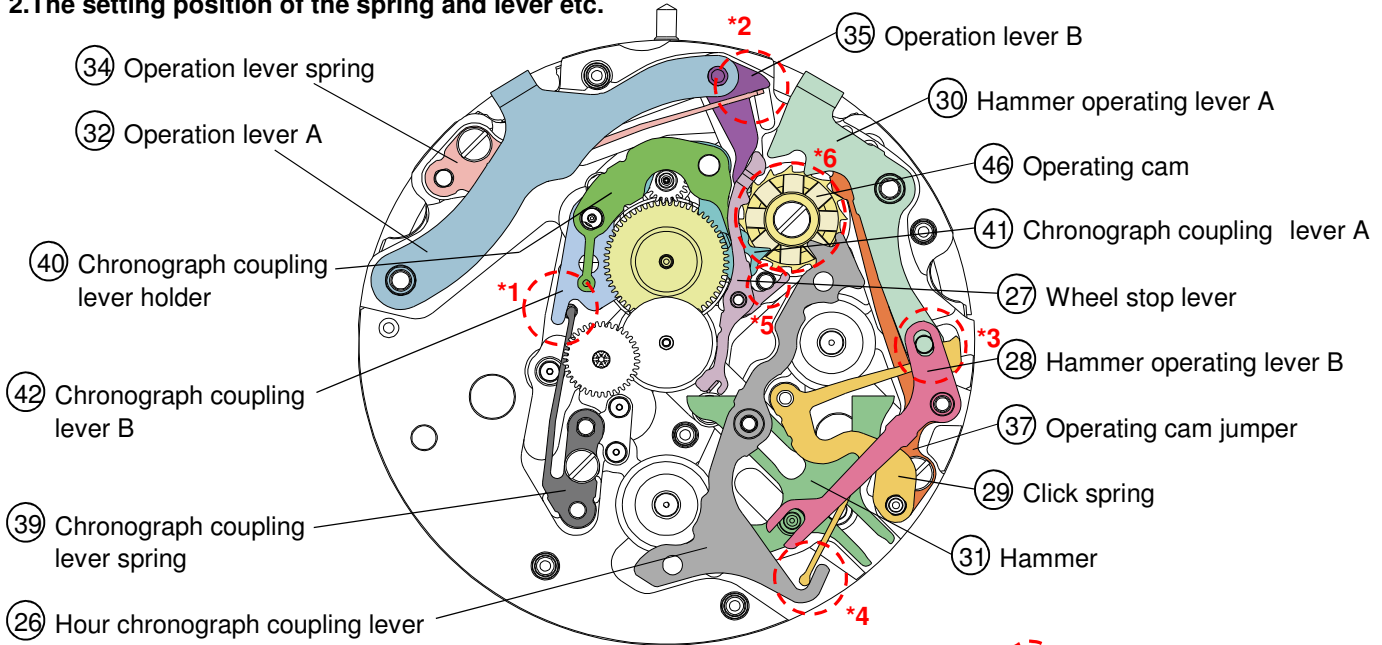

Setting position

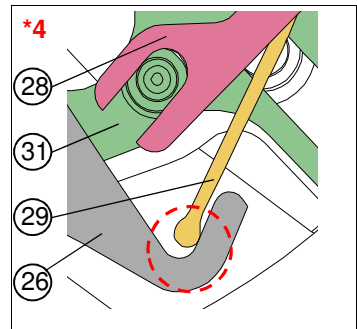
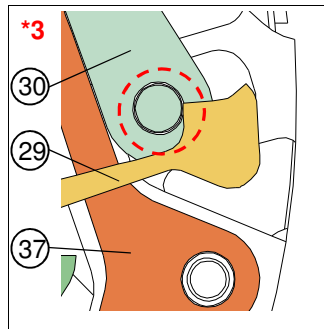
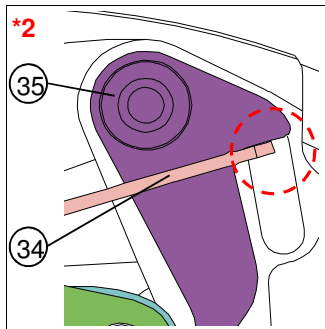
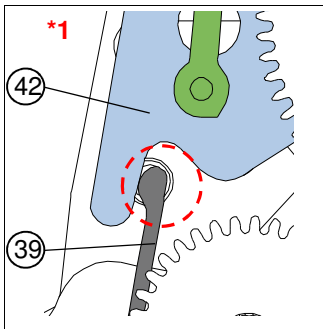

*6 The setting position of the operation cam with and lever.

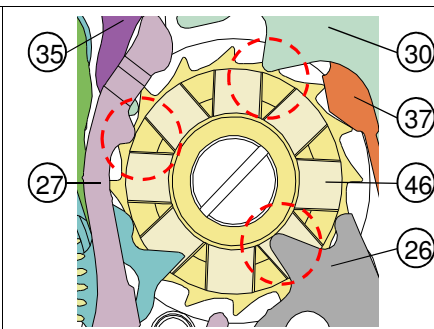
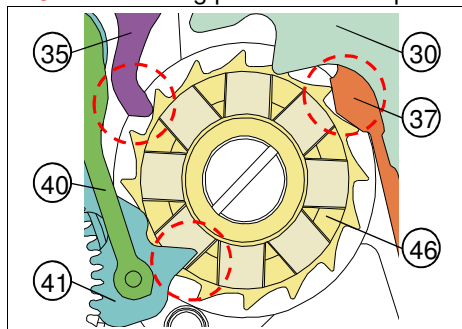
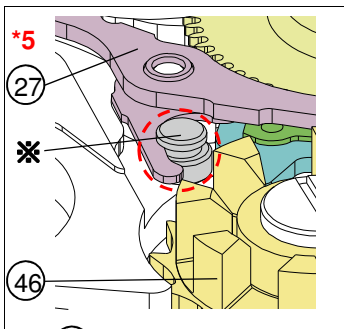

Note

If it is not possible to operate the button after assembling the movement, please recheck the spring position.

3. Chronograph coupling A and B setting position

Set chronograph coupling lever A and chronograph coupling lever B between the gears of second counting intermediate wheel.

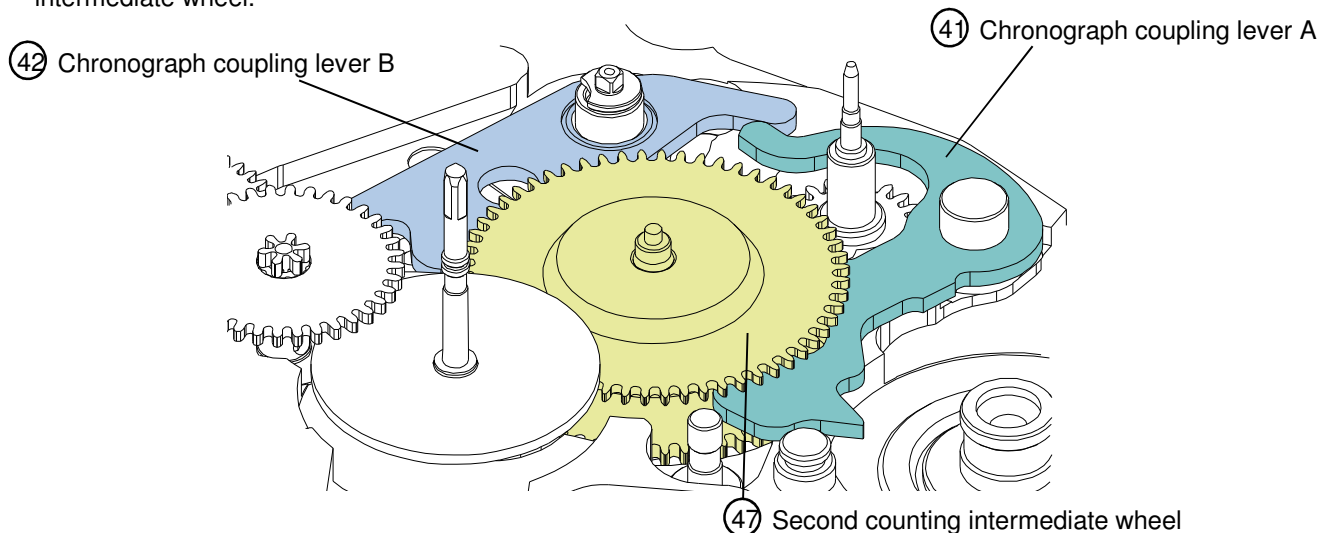

4. Hour chronograph coupling lever setting position

Hour and minute counting wheel need to be inclined when setting.

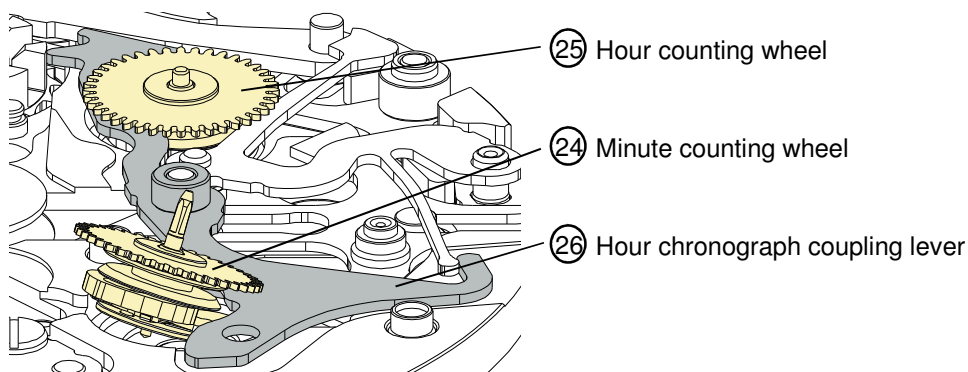

5. Second transmission wheel and minute transmission wheel setting position

Second transmission wheel and minute transmission wheel should be set parallel to main plate.

After detaching, it is prohibited to reuse them.

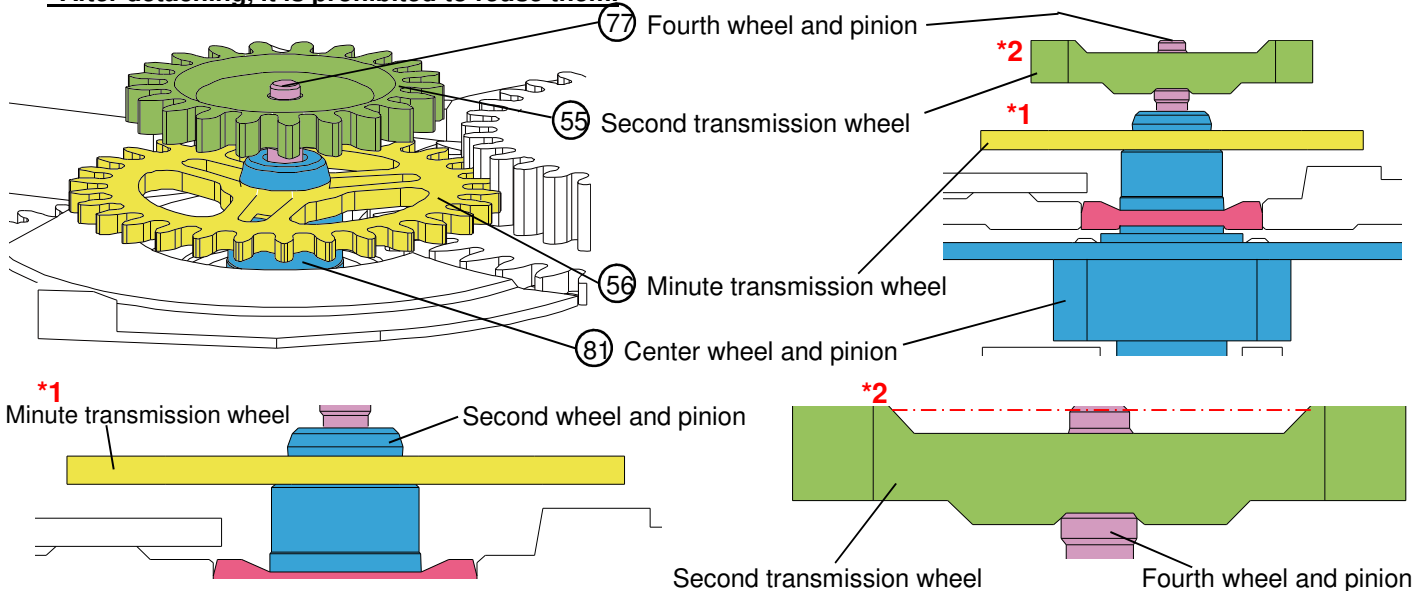

· Make sure to parallel with the main plate.
· But even if it is inclining a little, there is no problem if there are no other parts interfering together.

· The second transmission wheel top surface should be set parallel with the fourth wheel and pinion tip.
· But even if it is inclining a little, there is no problem if there are no other parts interfering together.

6. Disassembling / assembling of the first reduction wheel and arbor

<< Disassembling >>

<< Assembling >>

74 First reduction wheel and arbor

74 First reduction wheel and arbor

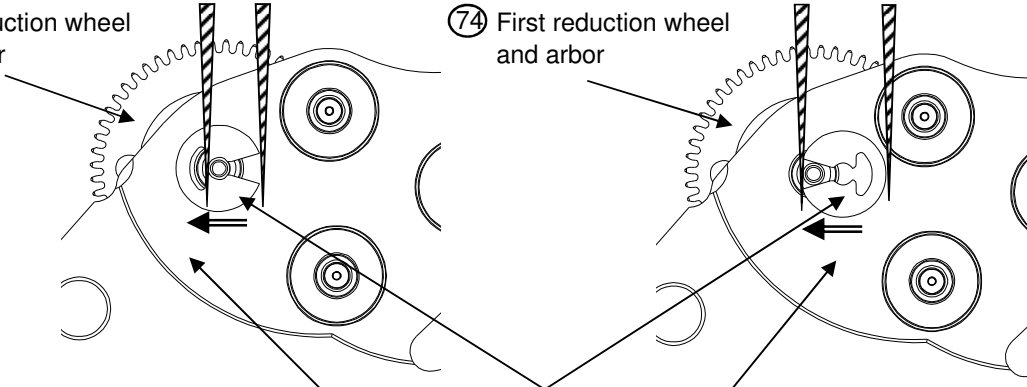

72 Reduction wheel holder

70 Barrel and train wheel bridge with hole jewel (back side)

7. Disassembling / assembling of the ratchet sliding wheel spring.

<< Disassembling >>

<< Assembling >>

71 Ratchet sliding wheel spring

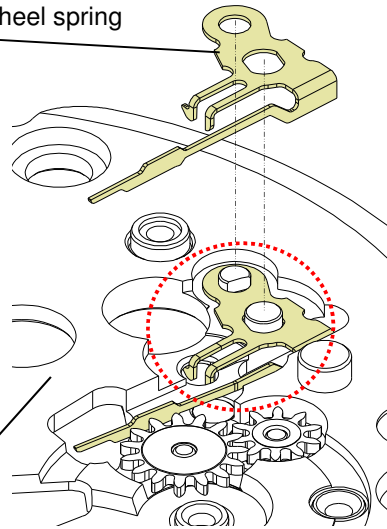
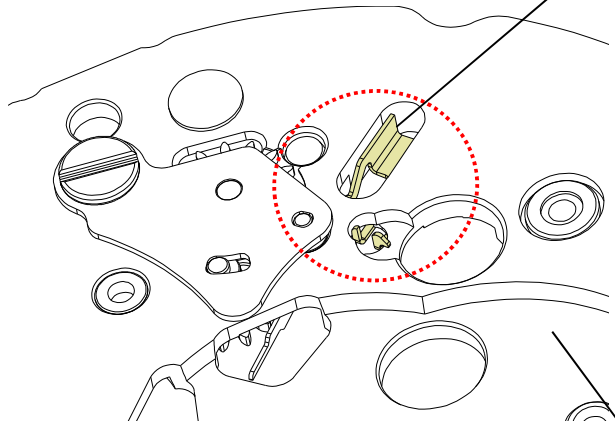

70 Barrel and train wheel bridge with hole jewel

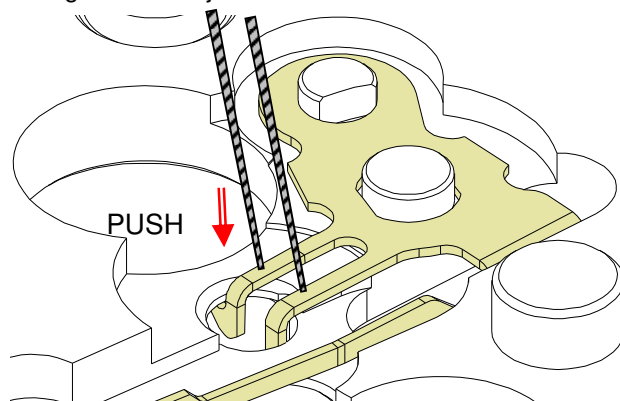
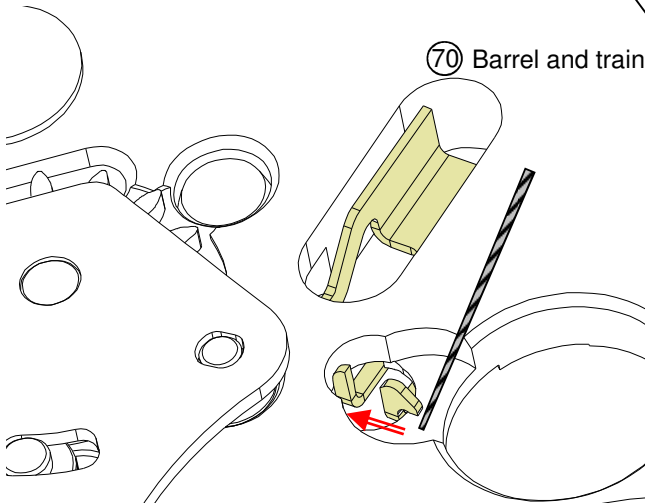

Remove the hook of ratchet sliding wheel spring from barrel and train wheel bridge with hole jewel.

The hooks of ratchet sliding wheel spring are hung up on barrel and train wheel bridge with hole jewel.

8. Chronograph unit and Base Unit (Disassembling and Reassembling)

Detachment of the chronograph unit and base unit by taking off the screws (4pcs.)

Attachment of the chronograph unit with the base unit.

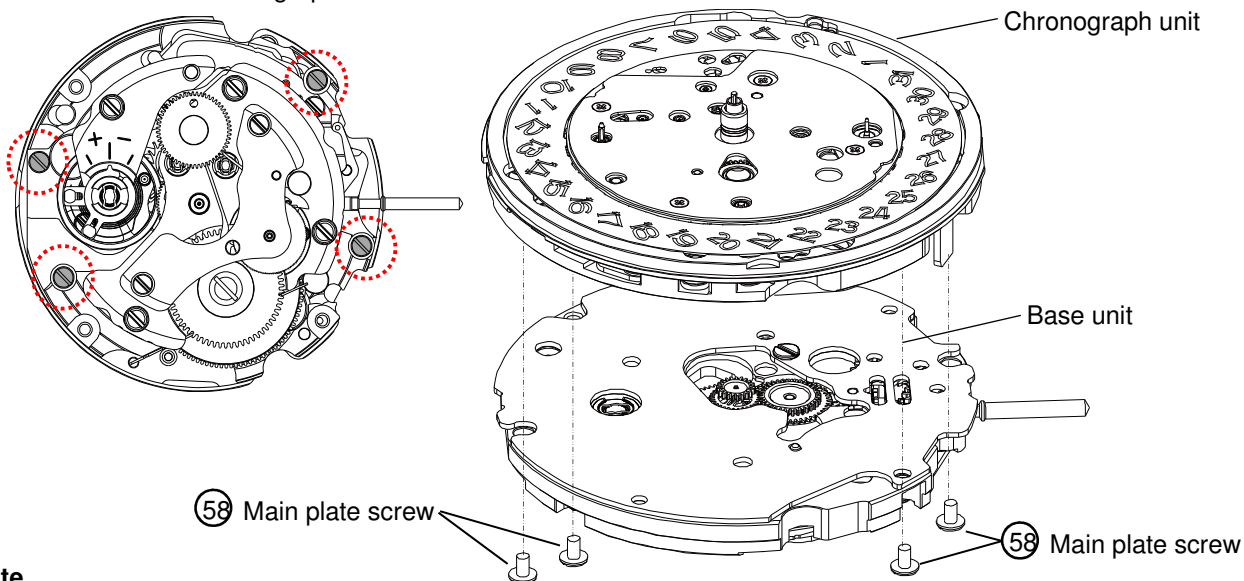

Note

When attaching chronograph unit on base unit, set the push button A in START position, in order to ensure that the following wheels mesh perfectly with one another.

Crown position	Base unit	Chronograph unit	Check point
First position	⑤1 Date corrector setting transmission wheel D	Date corrector setting transmission wheel E	Date display with quick correction
Second position	⑤6 Minutes transmission wheel	Minute wheel pinion A	Hand setting
	⑤5 Seconds transmission wheel	Seconds counter intermediate wheel	Driving

Before attaching the chronograph unit, check that base unit operates correctly.

9. Method to distinguish between dial washers

Parts name	Parts code	Set position	Note
②0 Dial washer B (X2)	0491 181	 Minute counting wheel Hour counting wheel	· Color of Brass · Handling caution
①9 Dial washer C	0491 182	 Minute counter intermediate wheel and pinion B	· Color of Silver
②1 Dial washer D	0491 183	 Second wheel	· Color of Brass

10. Accuracy adjustment

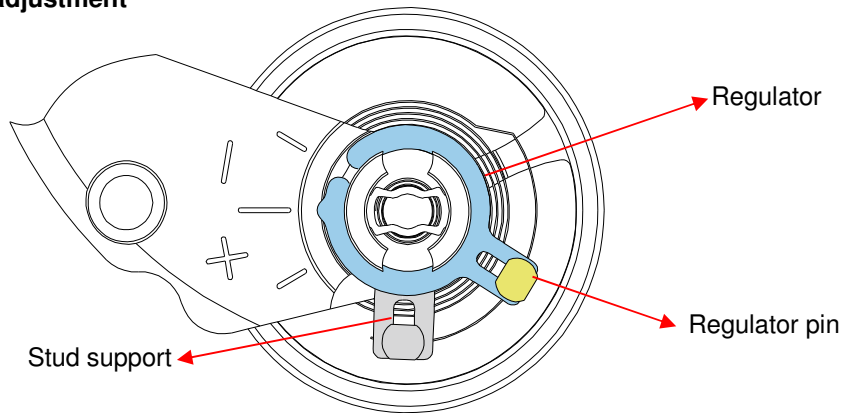

Note:

• Regulator ... Time adjustment

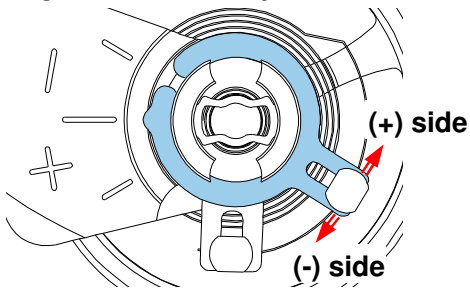

• Stud support ... Beat error adjustment

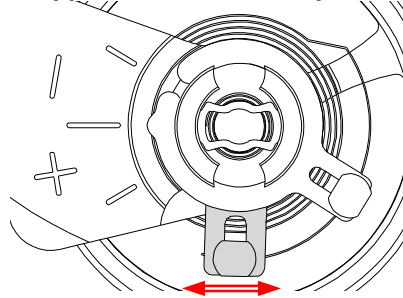

• Regulator pin ... Gap adjustment of balance spring and regulator pin

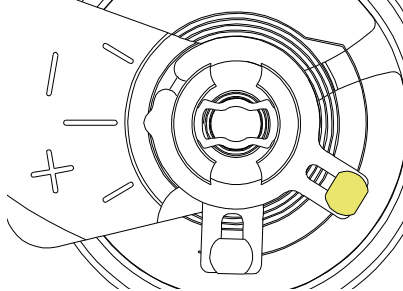

Anticlockwise rotation

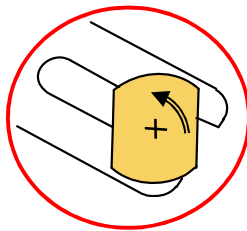

No clockwise rotation

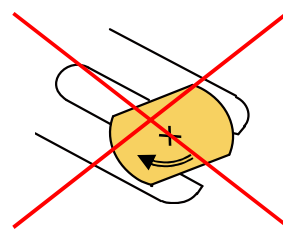

11. Setting position of oscillating weight

· Before assembling oscillating weight.

Match the center of oscillating weight and winding stem.

Set the hole of first reduction wheel gear on the imaginary line toward balance bridge guide pin.

Note

This procedure is necessary to maximize the performance of automatic winding.

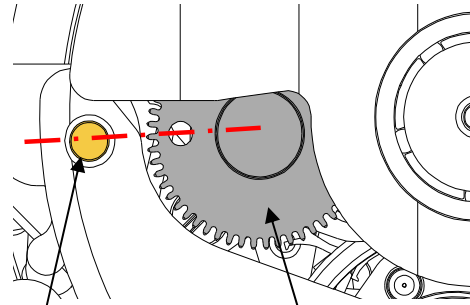
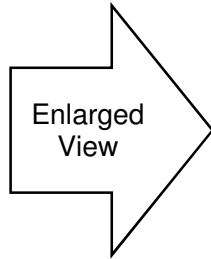
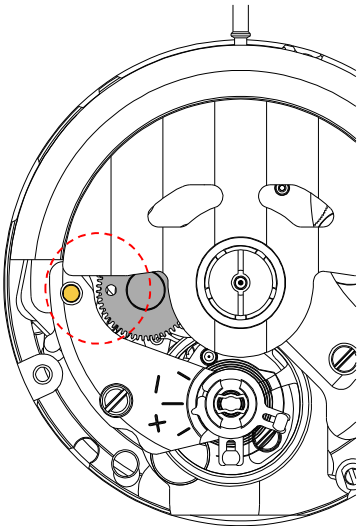

Balance bridge guide pin

First reduction wheel gear

12. To remove winding stem

- 1) Set winding stem to normal position.
- 2) Pull out winding stem while pushing "A".

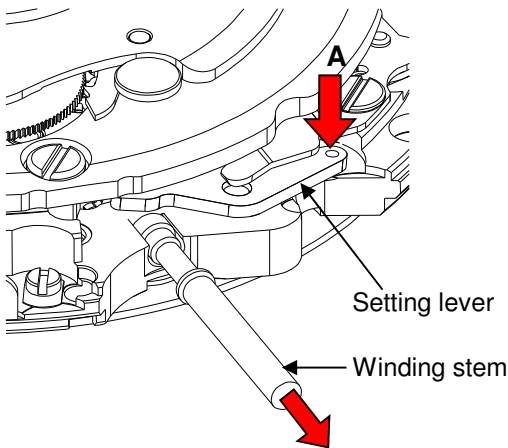

Setting lever

Winding stem

13. To wind up the mainspring

The mainspring would be fully wound up by turning ratchet wheel screw 8 times clockwise.

- Manual winding ... Rotate crown clockwise at normal position by minimum 55 times.
(Equal to ratchet wheel screw 8 times)

- Screwdriver winding ... Turn ratchet wheel screw 8 times clockwise.

[Manual winding]

[Screwdriver winding]

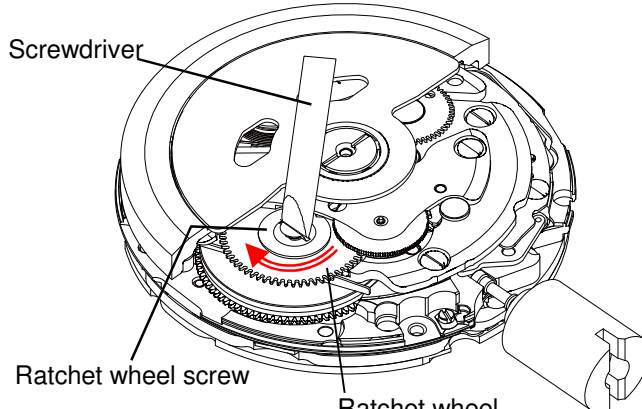
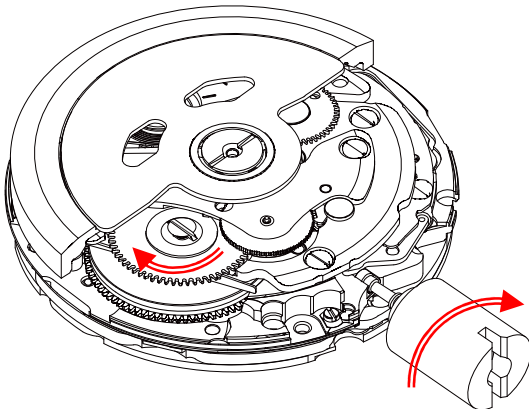

Screwdriver

Ratchet wheel screw

Ratchet wheel

14.How to attach hands

Place the movement directly on a flat metal plate or something similar to attach hands.

We recommend the use of movement holder to attach hands.

For hands attachment, please use a special equipment.

When the movement receives a strong shock, it may be damaged.

Note: Second / minute chronograph hands setting

- (1) Push button A (chronograph start)
- (2) Push button A (chronograph stop)
- (3) Push button B (chronograph reset)
- (4) After (1)~(3), install the second hand at "12" o'clock, minute hand at "30"minute position.

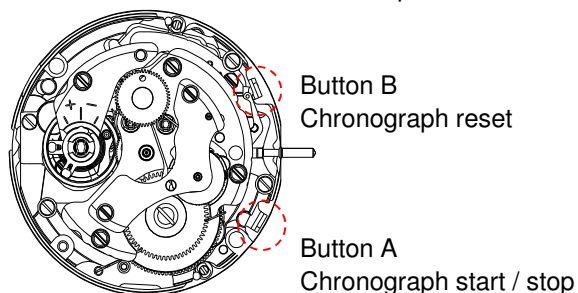
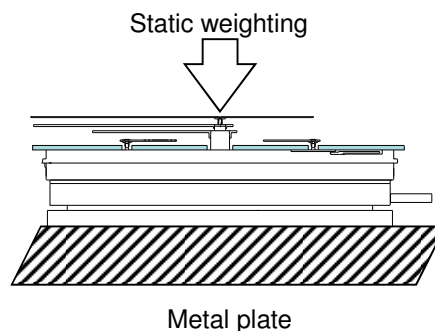

***Do not reuse the chronograph hands once detached. Please change and use new hands.**

Note

During time setting, if the chronograph is started, chronograph minute hand will rotate simultaneously.

This is not a malfunction. Please reset chronograph by pushing button B.

Chronograph minute hand will return to their reset positions.

15.Accuracy measurement condition

Static accuracy : -15~+25 second per day

Measurement conditions

- (1) Measurement should be done within 10~60 minutes after fully wound up.
- (2) Lift angle : 51 deg.
- (3) Measurement position : ① Dial up ② 9 o'clock ③ 6 o'clock
- (4) Minimum measurement time : 20 seconds
- (5) Stabilizing time

Leave the watch for at least 20 seconds to stabilize after you change its measurement position.

DISPLAY AND CROWN / BUTTON OPERATION

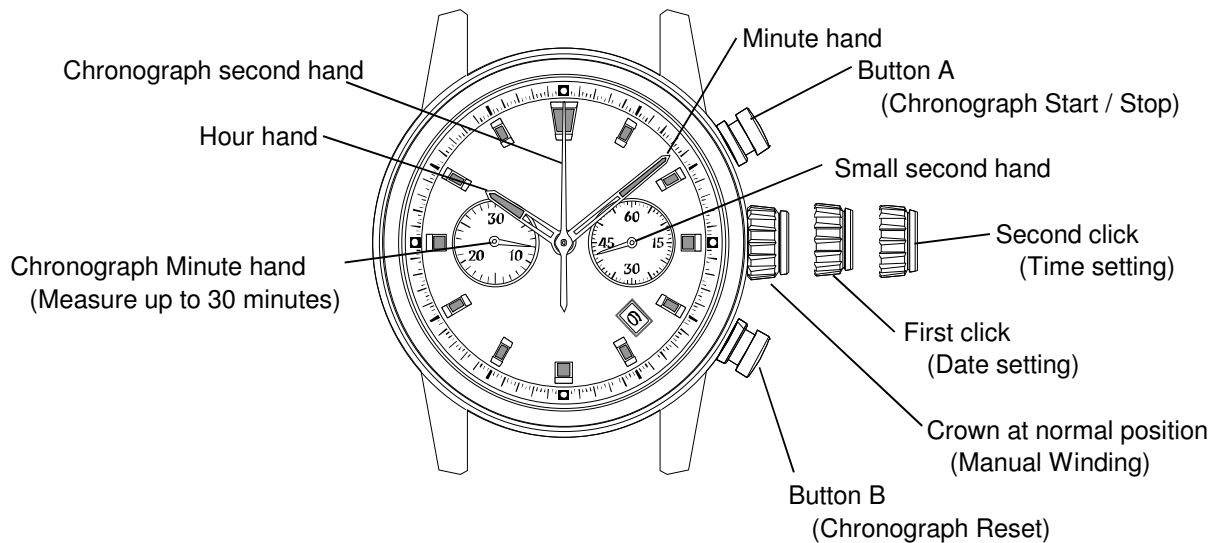

1. How to set the time

- 1) Pull out the crown to the second click position.
- 2) Turn the crown to set hour and minute hands.
(Check that AM / PM is set correctly.)
- 3) Push the crown back into the normal position.

Note

During time setting, if the chronograph is started, chronograph hour and minute hands will rotate simultaneously. This is not a malfunction. Please reset chronograph by pushing button B. Chronograph hour and minute hands will return to their reset positions.

2. How to set the date

- 1) Pull out the crown to the first click position.
- 2) Turn the crown to left for date setting.
*Do not set the date between 8:00 P.M. and 2:00 A.M. as this will cause a malfunction.
- 3) Push the crown back into the normal position.

3. To wind up the mainspring

- 1) Manual winding ... Rotate the crown clockwise at normal position.
 - Fully wound up by turning the crown minimum 55 times.
 - Fully wound up by turning the ratchet wheel screw 8 times.

It will start to move naturally shaking slightly.
- 2) To wind up with winding machine.
 - Rotary speed : 30 rpm
 - Operating time : 60 minutes

HOW TO USE THE CHRONOGRAPH

[Standard measurement]

Press the buttons in the following order : A → A → B

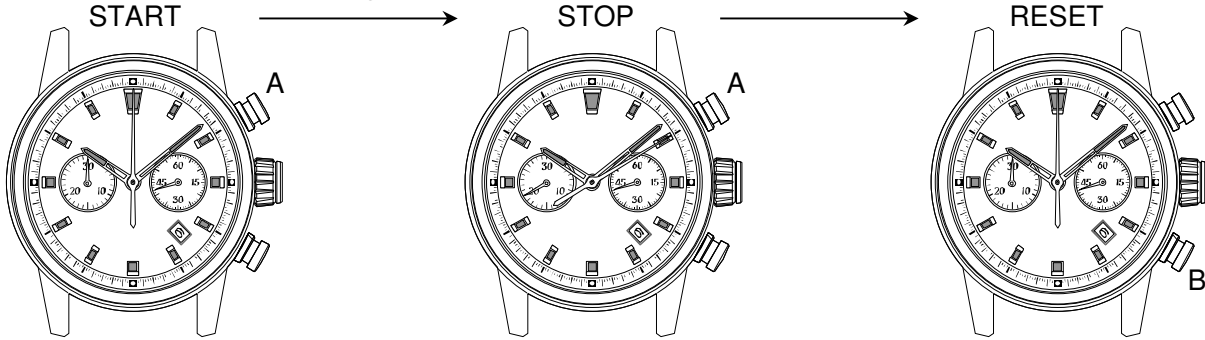

(20 minutes 10 seconds)

· Press button A to start chronograph.
Chronograph second hand will start moving.

· Press button A again to stop chronograph.
Chronograph hands stop to indicate the elapsed time.

· Press button B to reset chronograph.
All chronograph hands will be reset to "0" position.

[Accumulated elapsed time measurement]

Press the buttons in the following order : A → A / A ... → A → B

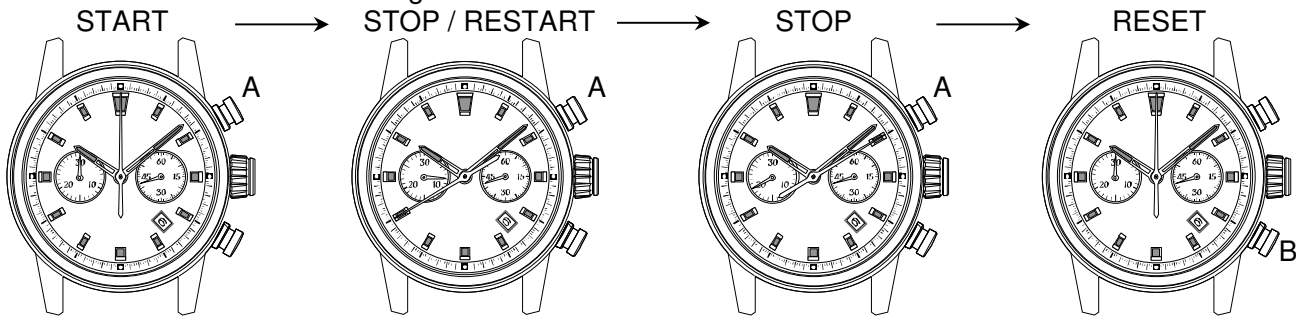

(8 minutes 40 seconds)

(20 minutes 10 seconds)

*Restart and stop of chronograph can be repeated as many times as necessary by pressing button A