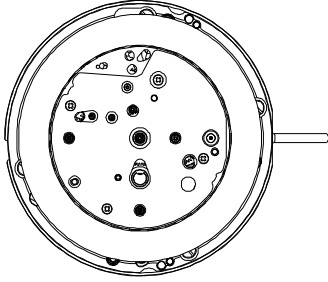
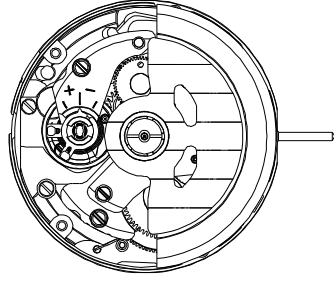

TECHNICAL GUIDE
&
PARTS CATALOGUE

Cal.NE88

AUTOMATIC MECHANICAL

SII Products

Item		Cal. Code	NE88
Movement			 
Movement size	Outside diameter	Φ 28.60mm	
	Casing diameter	Φ 28.00mm	
	Total height	7.62mm	
Time indication			2 Hands (Hour , Minute) Small Second hand / 3 o'clock Date Calendar Chronograph 60 seconds counter / Center 30 minutes counter / 9 o'clock 12 hours counter / 6 o'clock
Basic function			Manual winding Automatic winding with ball bearing Stop second device Date display with quick correction
Frequency			28,800 vibrations per hour
Accuracy	Static accuracy		-15~+25 seconds per day * Measurement should be done within 10~60 minutes after fully wound up. * All measurements are made without the calendar in function. * All measurements are made without the chronograph in function.
	Measurement position		Direction of 3 positions. (1) Dial up (2) 9 o'clock up (3) 6 o'clock up
	Lift angle		51 deg.
	Measurement time		20 seconds * Equipment to be used : Witschi WATCH EXPERT
	Posture difference		Difference is under 45 seconds within max value and min. value. * Measurement should be done within 10~60 minutes after fully wound up. * Direction of 4 positions. (1) 12 o'clock up (2) 9 o'clock up (3) 6 o'clock up (4) 3 o'clock up
	Isochronisms (24h-0h)		-10~+20 seconds per day. * Direction of position. : Dial up * Difference of static accuracy of 24h and 0h
Duration time			More than 45 hours ... Mainspring after fully wound up. * Posture to confirmation : Dial up * Measurements are made without the chronograph in function.
Winding the mainspring			<< Movement >> • Fully wound up by turning the crown min. 55 times. • Fully wound up by turning the ratchet wheel screw 8 times. << Complete Watch >> A winding machine is needed to wind up the mainspring. Full wind up conditions • Rotary speed : 30 rpm • Operating time: 60 minutes
Jewels			34 jewels
Crown position		Left rotation	Right rotation
	Normal position	Free	Manual winding
	First click	Date setting	Free
	Second click	Hand setting	Hand setting
Button position	2 o'clock	Chronograph Start & Stop	
	4 o'clock	Chronograph Reset	

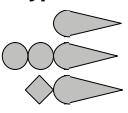
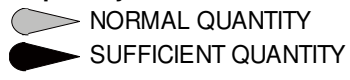
Disassembling procedures Figs. ① ⇒ ⑨③	Type of oil  Moebius 9010 MO-4 MO-3	Oil quantity mark  NORMAL QUANTITY SUFFICIENT QUANTITY
Reassembling procedures Figs. ⑨③ ⇒ ①		

[NOTE]

**Some parts cannot move when the chronograph is at RESET position.
Please press button A to START the chronograph before assembly / disassembly.**

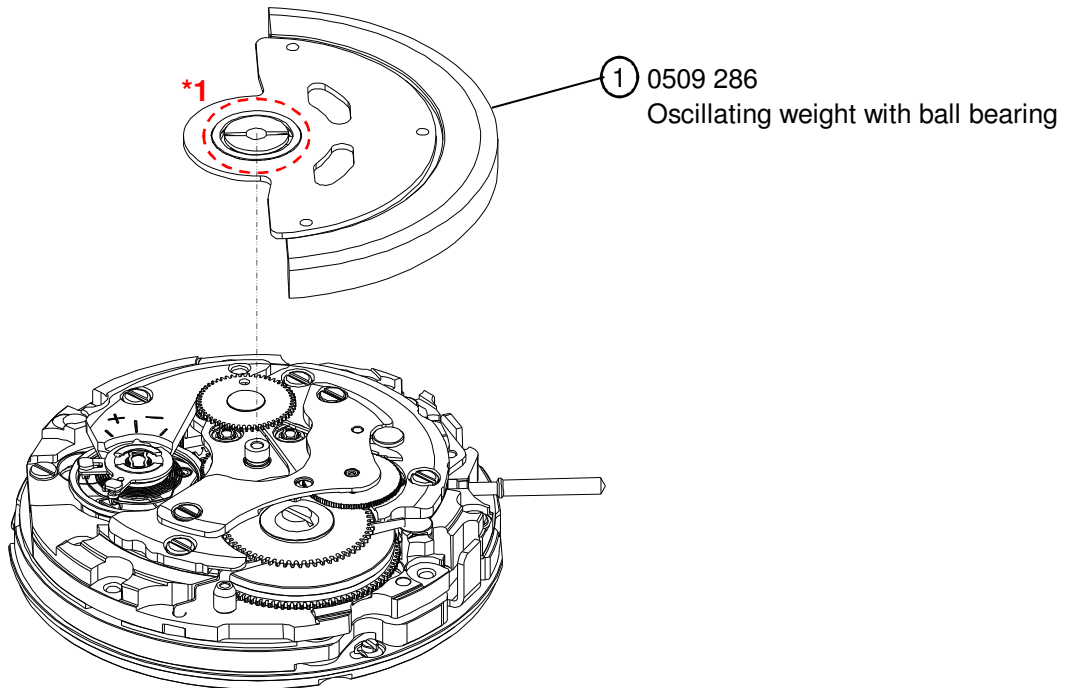
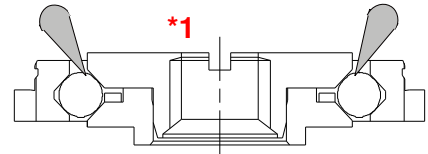
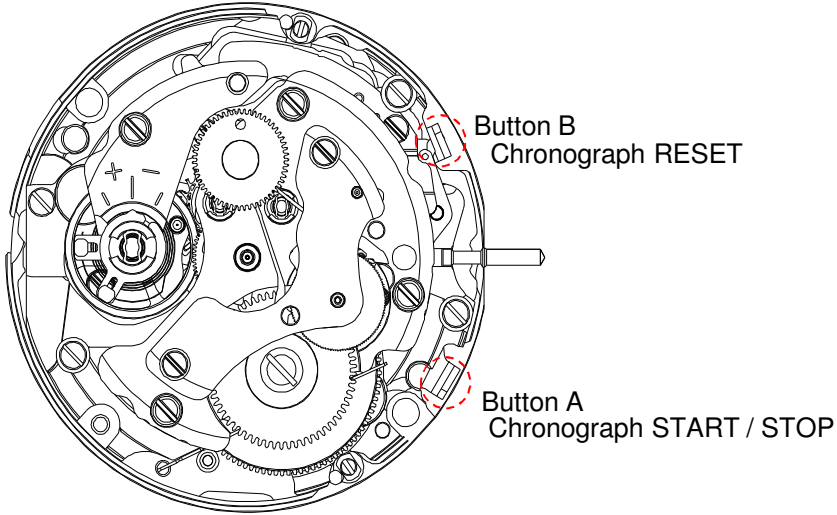

Type of oil

Moebius 9010





MO-4
MO-3

Oil quantity mark

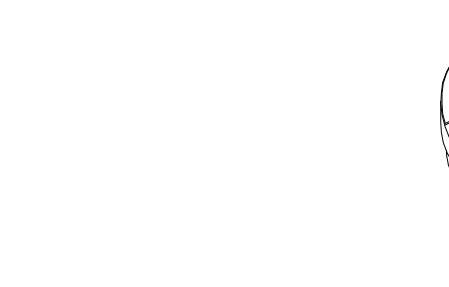
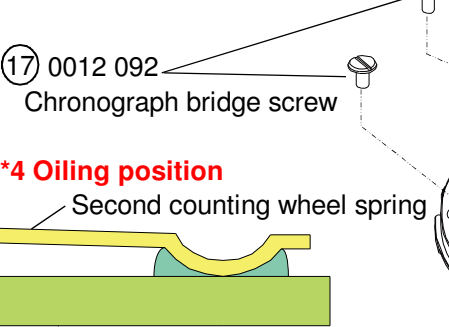
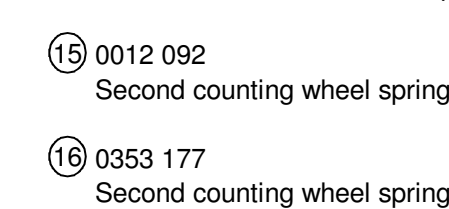
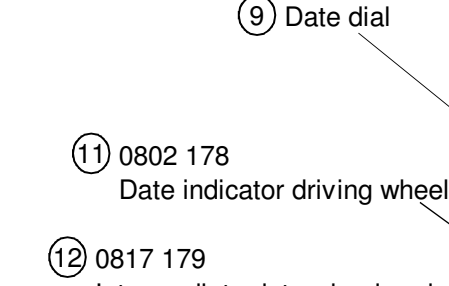
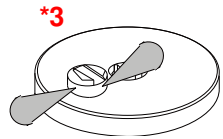
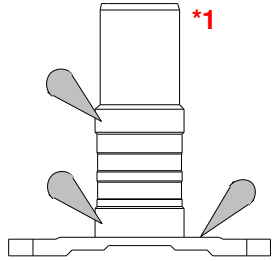
NORMAL QUANTITY

SUFFICIENT QUANTITY





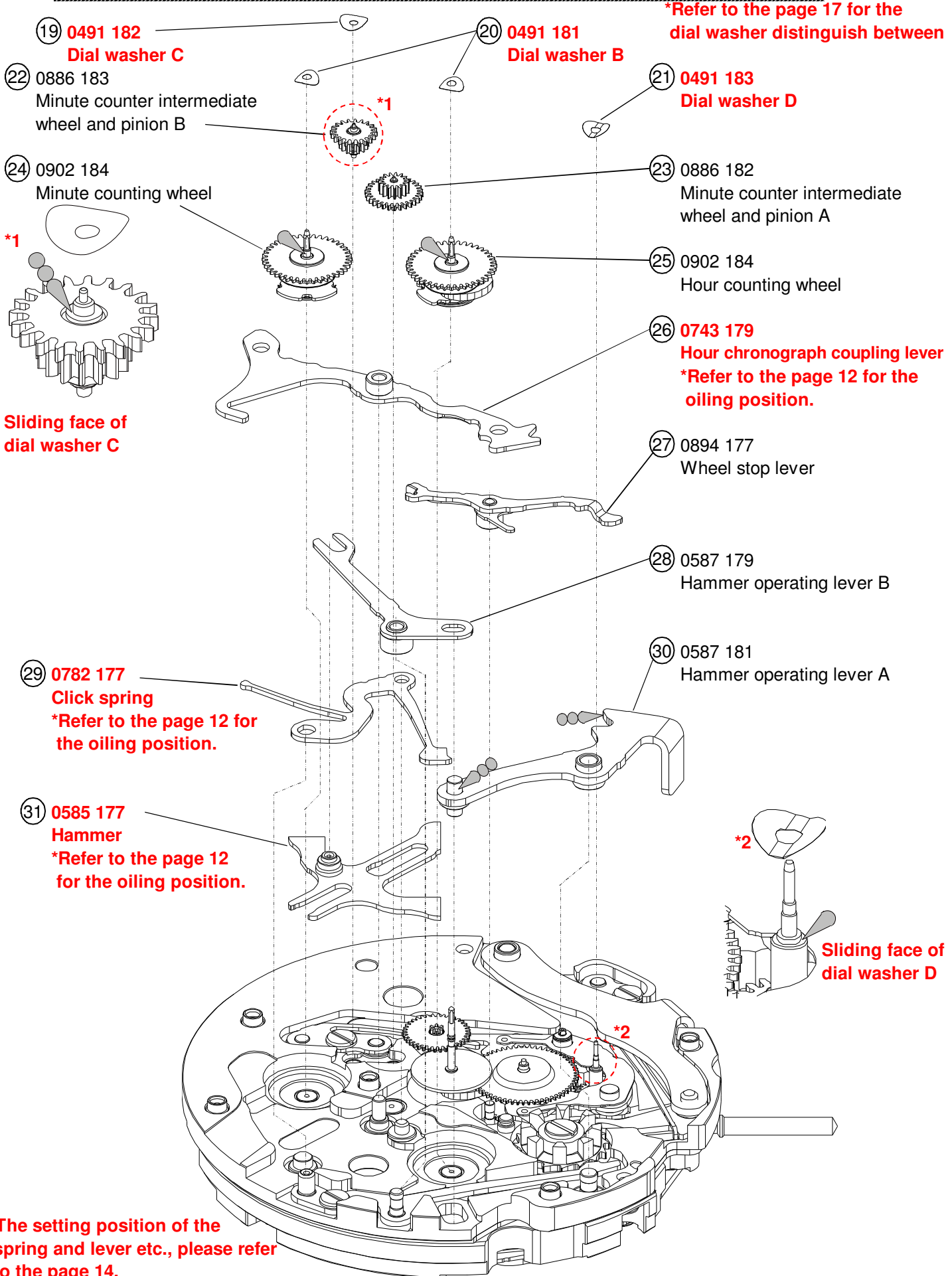



Type of oil		Oil quantity mark	
	Moebius 9010		NORMAL QUANTITY
	MO-4		SUFFICIENT QUANTITY
	MO-3		

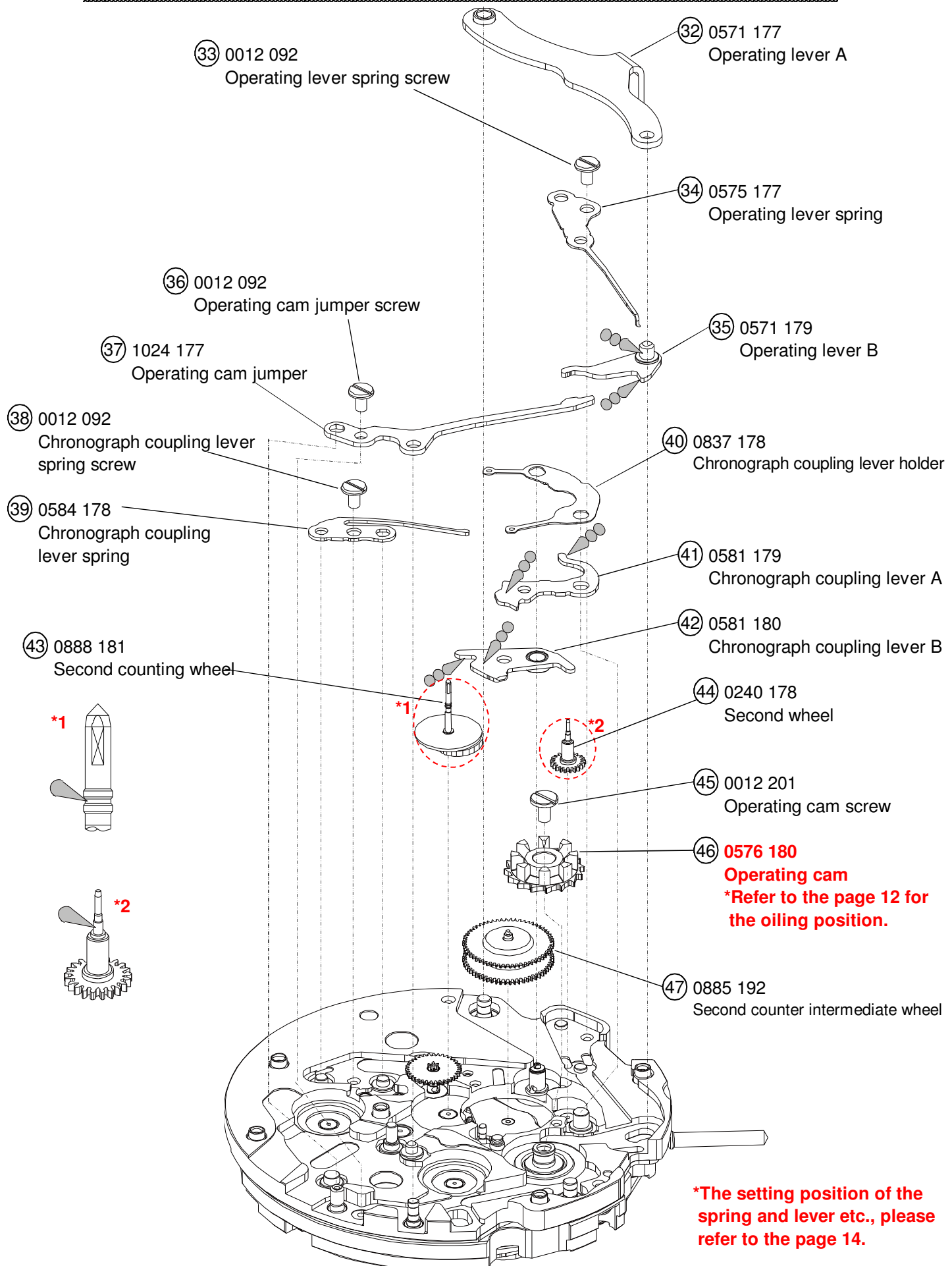

*The setting position of the spring and lever etc., please refer to the page 14.

Type of oil		Oil quantity mark	
	Moebius 9010		NORMAL QUANTITY
	MO-4		SUFFICIENT QUANTITY
	MO-3		



Type of oil		Oil quantity mark	
	Moebius 9010		NORMAL QUANTITY
	MO-4		SUFFICIENT QUANTITY
	MO-3		

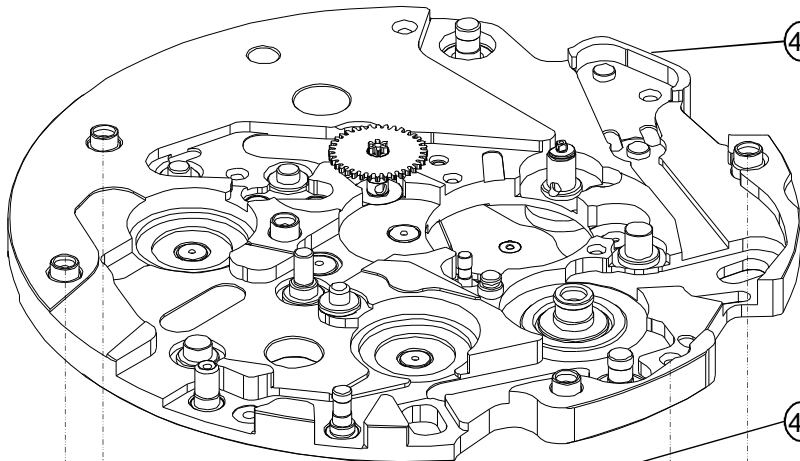

48 0186 192
Chronograph main plate
***Refer to the page 13 for the oiling position.**

49 0012 354
Unit intermediate spacer screw

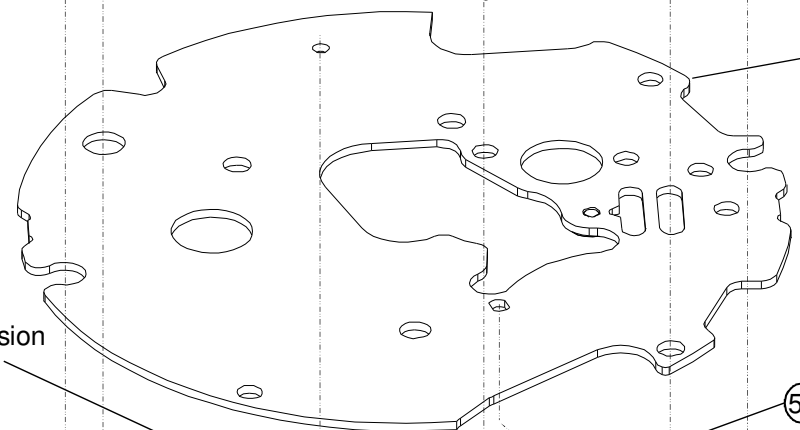

***5**
Refer to the page 15 for the setting position.

54 0817 180
Time setting transmission wheel and pinion

55 0505 181
Seconds transmission wheel

56 0505 182
Minutes transmission wheel
***Refer to the page 12 for the oiling position.**

50 4408 181
Unit intermediate spacer

51 0962 023
Date corrector setting transmission wheel D

52 0962 023
Date corrector setting transmission wheel C



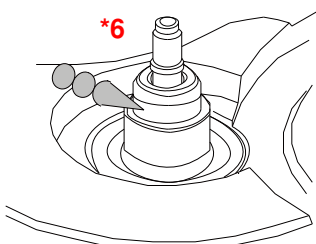
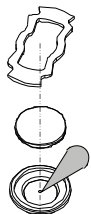
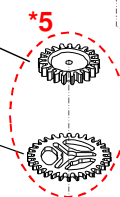

53 0962 190
Date corrector setting transmission wheel B







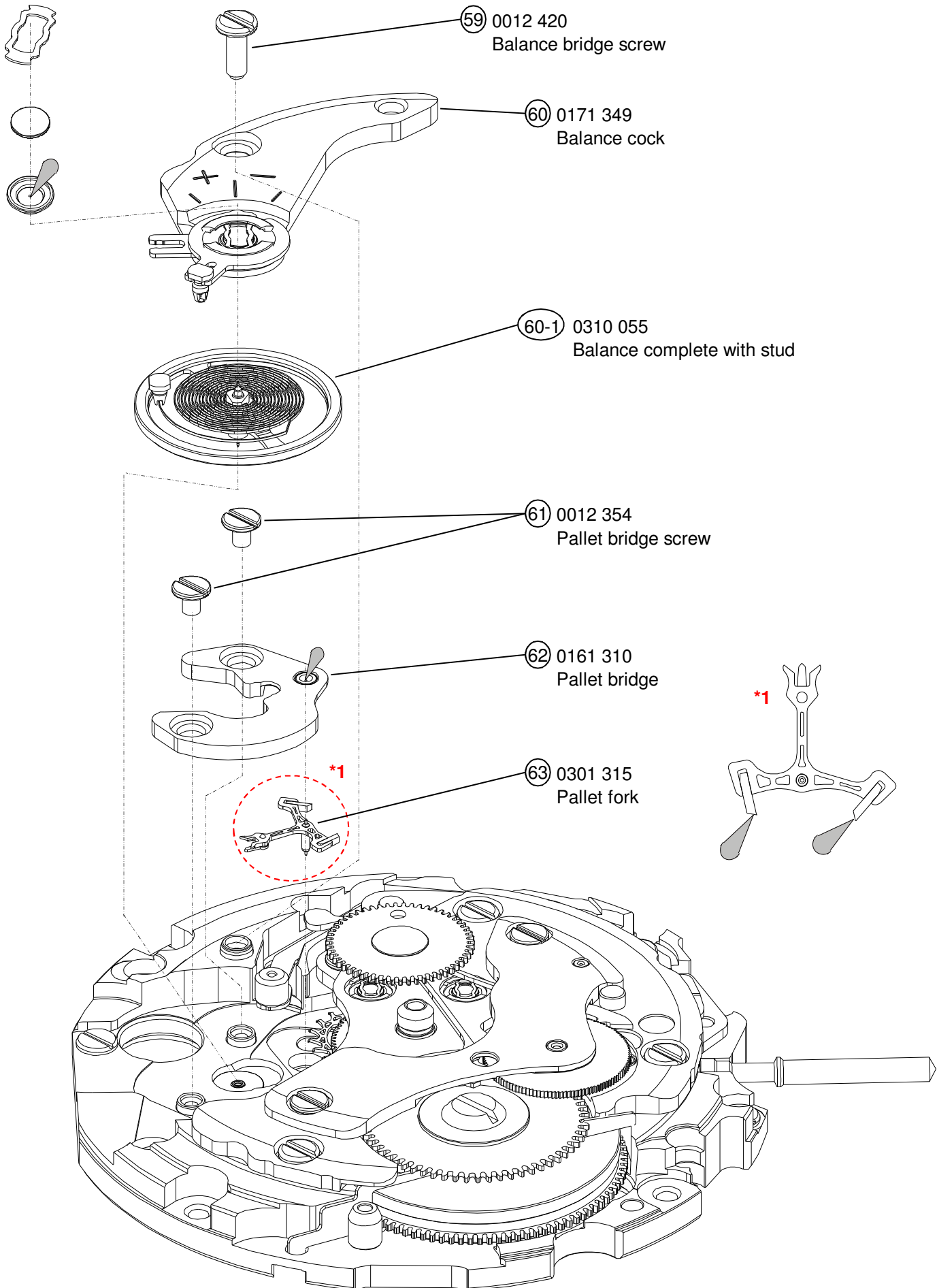

57 Main plate

58 0012 092
Main plate screw





58 0012 092
Main plate screw

Type of oil		Oil quantity mark	
	Moebius 9010		NORMAL QUANTITY
	MO-4		SUFFICIENT QUANTITY
	MO-3		

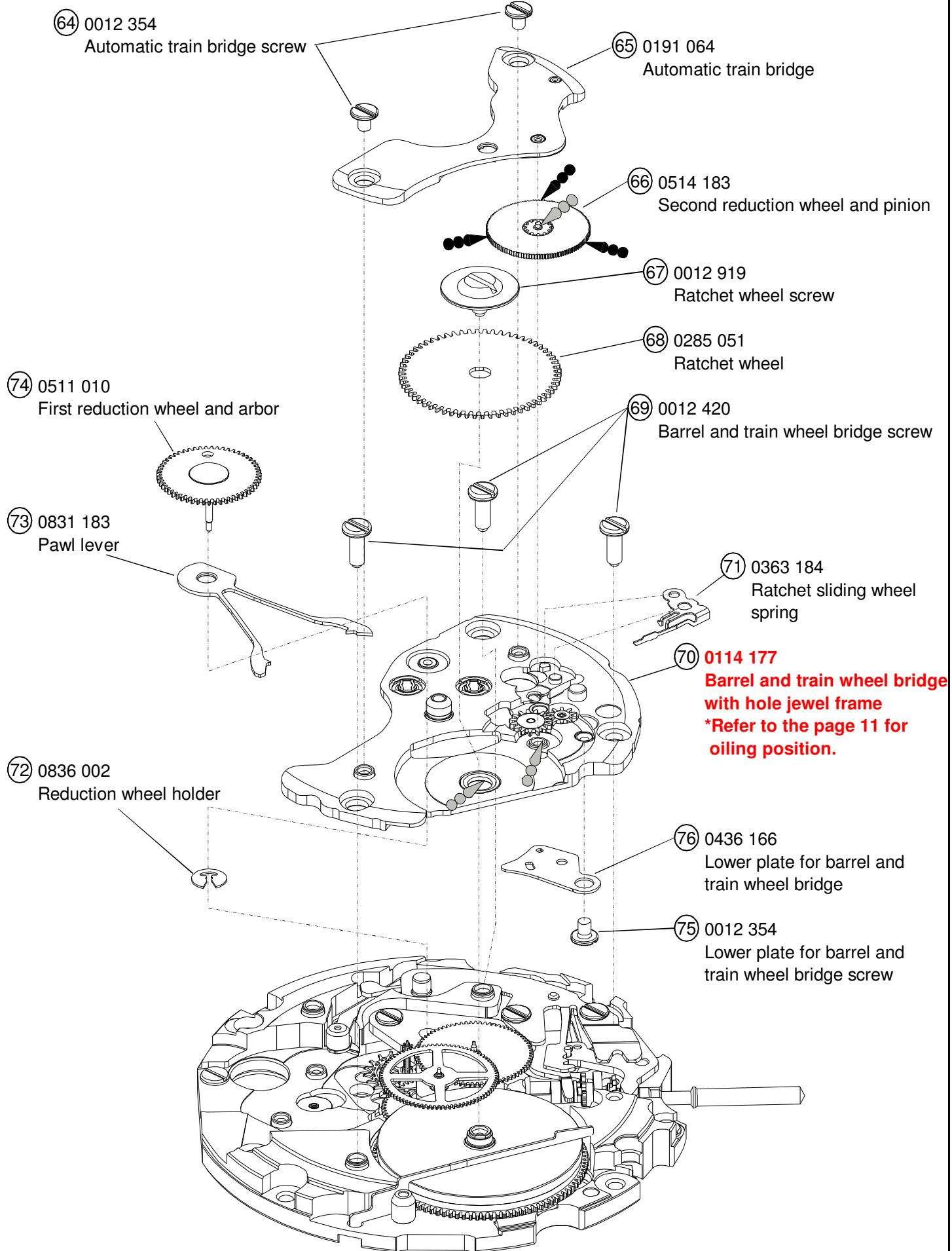

Type of oil		Oil quantity mark	
	Moebius 9010		NORMAL QUANTITY
	MO-4		SUFFICIENT QUANTITY
	MO-3		



Type of oil		Oil quantity mark
 Moebius 9010	 MO-4	 NORMAL QUANTITY
	 MO-3	 SUFFICIENT QUANTITY

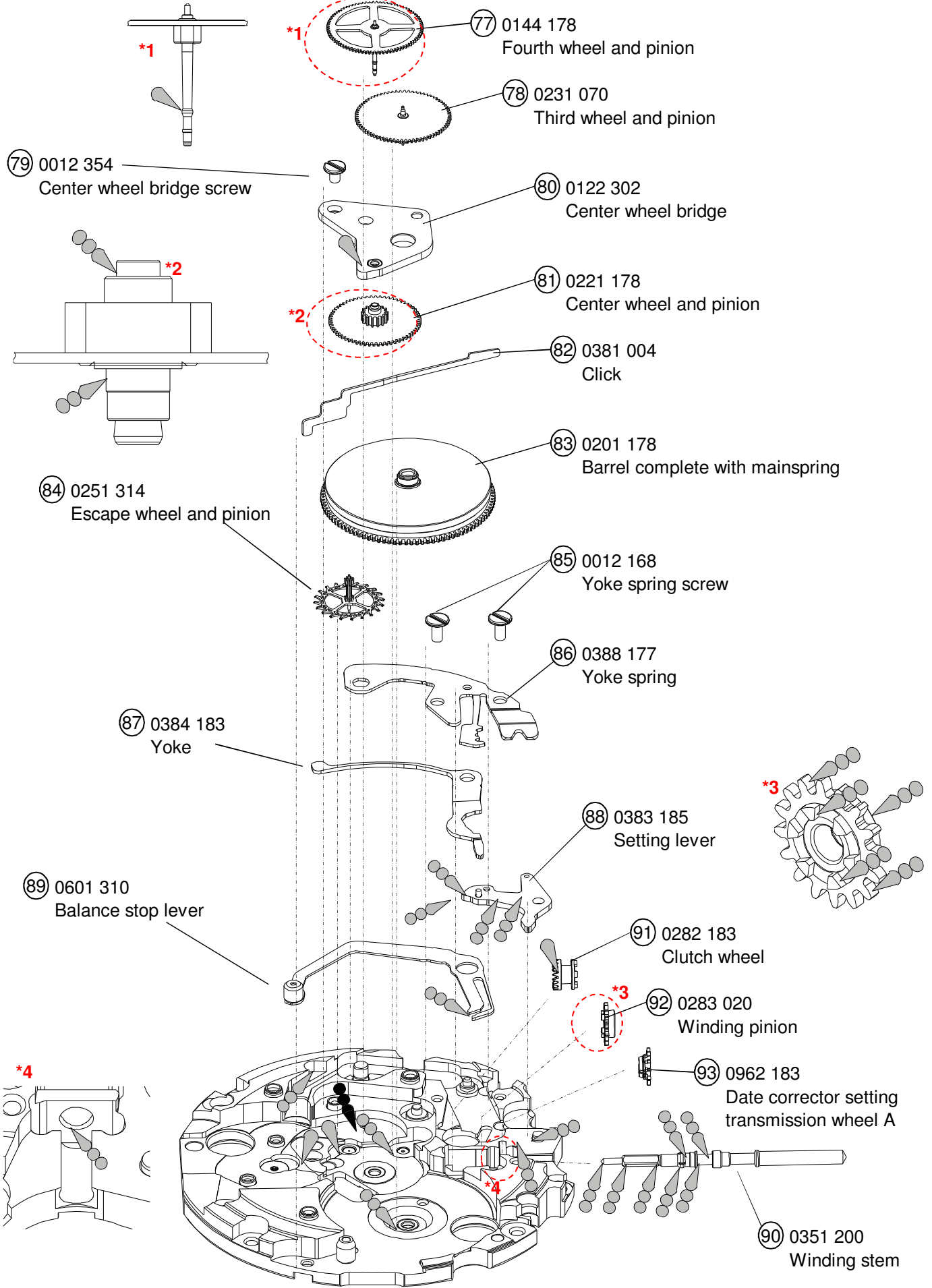



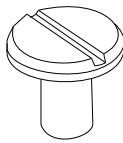
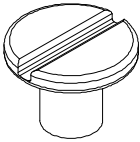
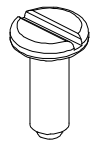
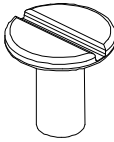
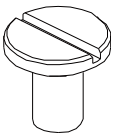
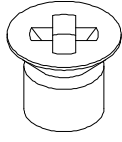
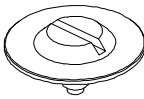

● List od screw

Parts code	Parts name	Parts code	Parts name	Parts code	Parts name
0012 092 	⑮ Second counting wheel spring screw	0012 354 	④⑨ Unit intermediate spacer screw	0012 420 	⑤⑨ Balance bridge screw
	⑰ Chronograph bridge screw (x5)		⑥① Pallet bridge screw (x2)		Barrel and train wheel bridge screw (x3)
	③③ Operation lever spring screw		⑥④ Automatic train bridge screw (x2)	0012 168 	⑧⑤ Yoke spring screw (x2)
	③⑥ Operation cam jumper screw		⑦⑤ Lower plate for barrel and train wheel bridge screw		
	③⑧ Chronograph coupling lever spring screw		⑦⑨ Center wheel bridge screw		
	⑤⑧ Main plate screw (x4)		0012 201 	④⑤ Operating cam screw	0016 709 
0012 919 	⑥⑦ Ratchet wheel screw	⑦ Date indicator maintaining plate screw			

⑨ Date dial

Parts code	Position of crown	Position of date frame	Color of numbers	Color of background
0878 109	3H	3H	Black	Silver (Plain metal)
0878 108	3H	3H	White	Black

***All parts code are subject to change without notice.**

Type of oil		Oil quantity mark	
	Moebius 9010		MO-4
			MO-3
			NORMAL QUANTITY
			SUFFICIENT QUANTITY

1.Oiling spot

(1) **70** Barrel and train wheel bridge with hole jewel frame

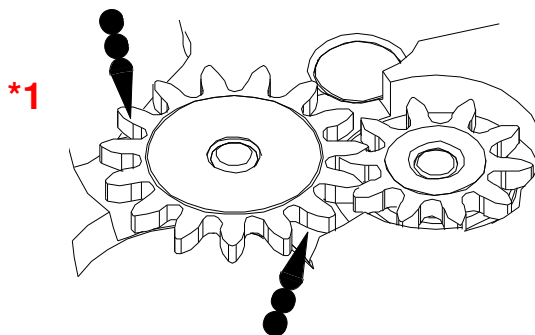
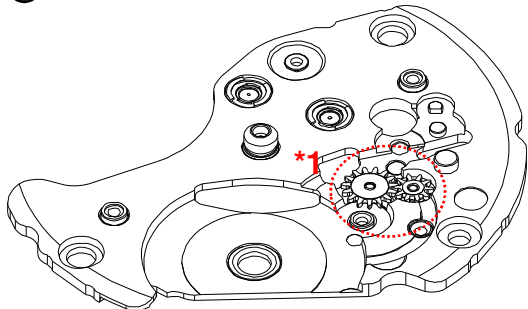

Barrel and train wheel bridge with hole jewel frame (back side)

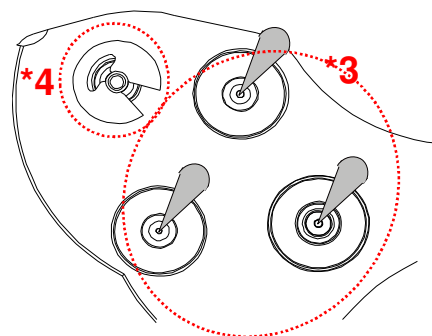
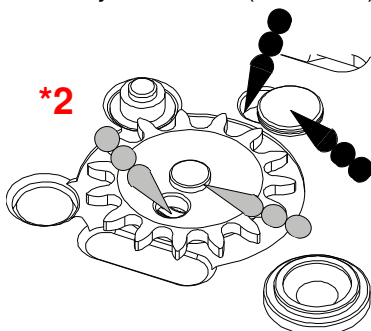
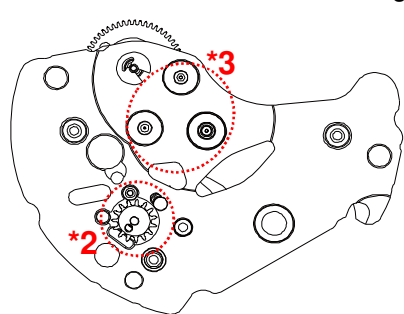

Note

***2** After oiling, set lower plate for barrel and train wheel bridge & screw.

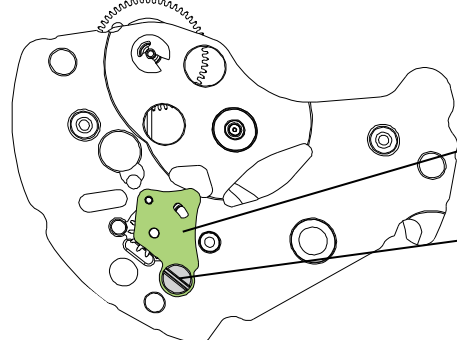

76 Lower plate for barrel and train wheel bridge

75 Lower plate for barrel and train wheel bridge screw

***4** After oiling, set first reduction wheel & pawl lever & reduction wheel holder.

74 First reduction wheel

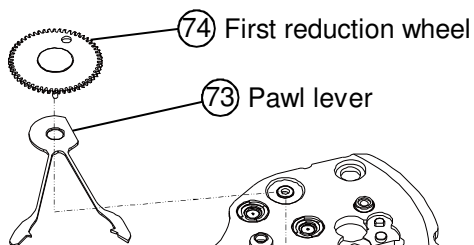
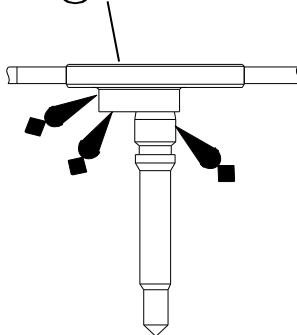

74 First reduction wheel



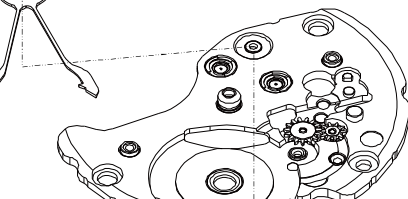

73 Pawl lever



72 Reduction wheel holder

Note

***Refer to the page 16 for disassembling and reassembling.**

Type of oil		Oil quantity mark
 Moebius 9010	 MO-4	 NORMAL QUANTITY
	 MO-3	 SUFFICIENT QUANTITY

1. Oiling spot

(2) (46) Operating cam

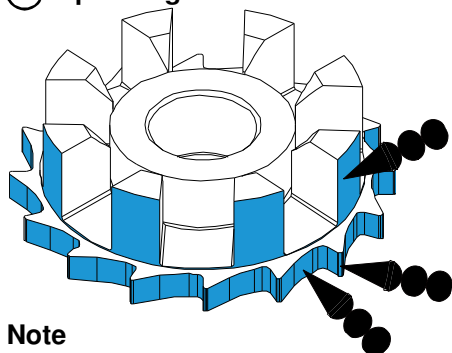

Note
Do oiling on all teeth

(3) (31) Hammer

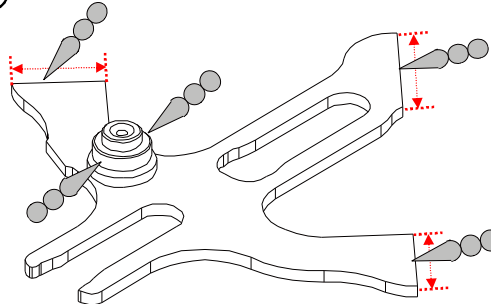

Note
There must be oil within the range of the arrow.

(4) (26) Hour chronograph coupling lever

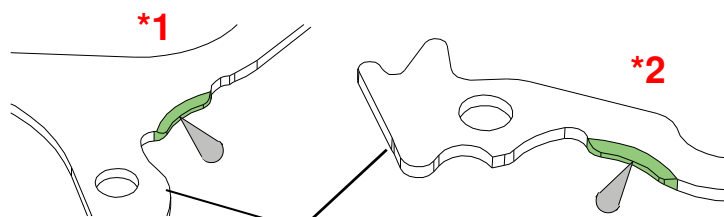
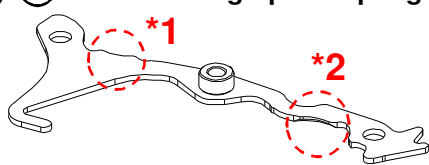

Back side

(5) (29) Click spring

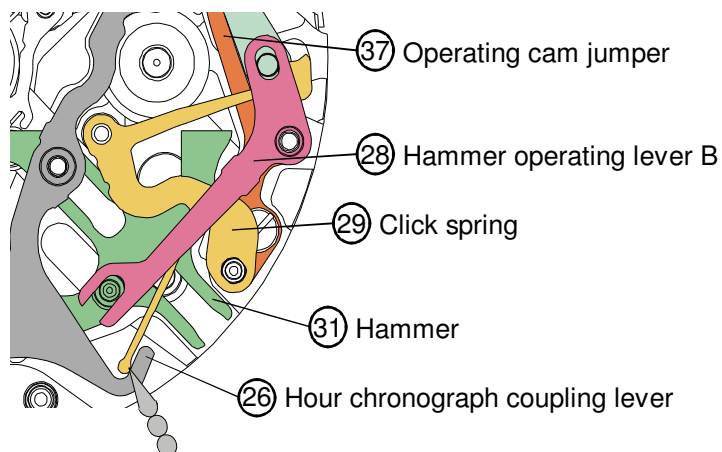
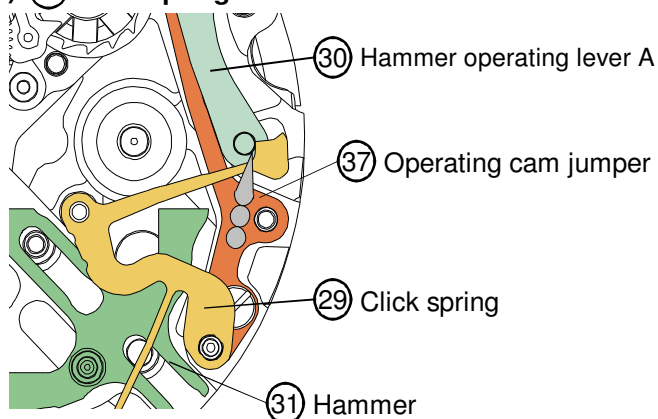

Note
There must be oil within the range of the arrow.

(6) (56) Minutes transmission wheel

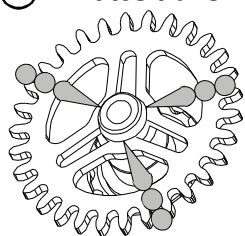

Type of oil

Moebius 9010

MO-4
MO-3

Oil quantity mark

NORMAL QUANTITY

SUFFICIENT QUANTITY

1. Oiling spot

(7) **48** Chronograph main plate

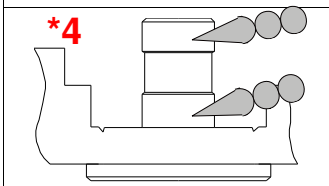
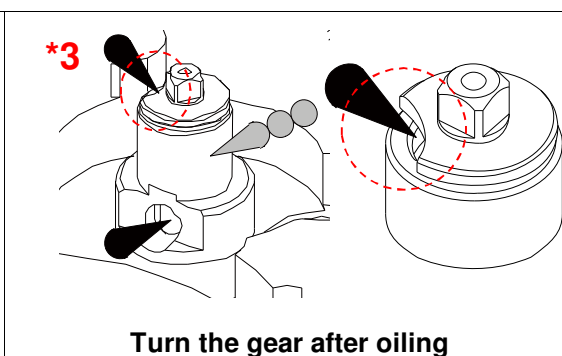
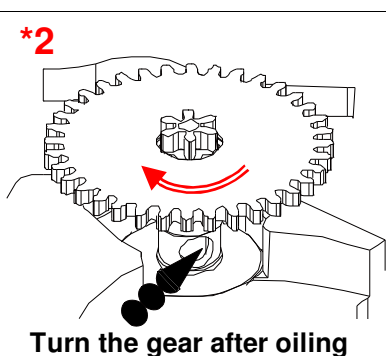
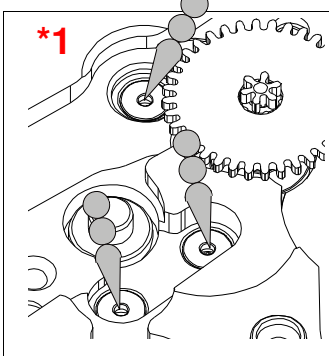
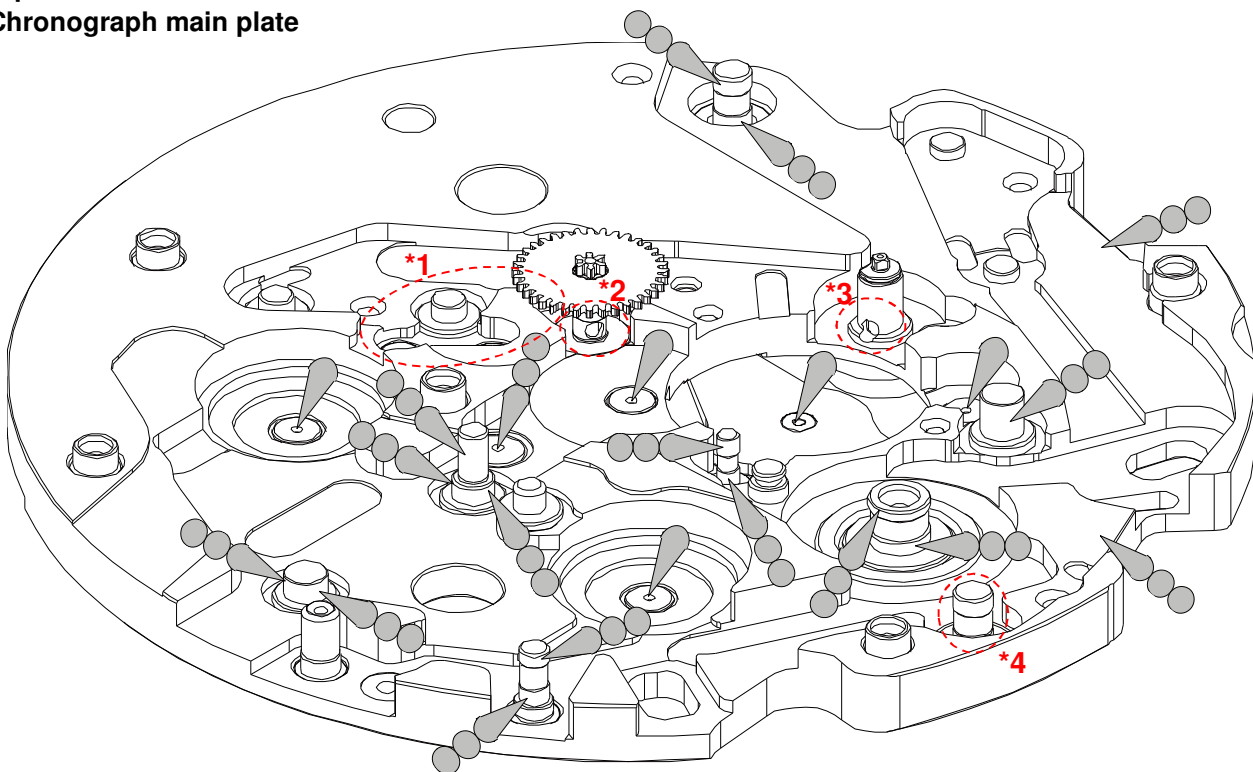

Note
There must be oil within the range of the arrow.

(8) **18** Chronograph bridge
[Front side]

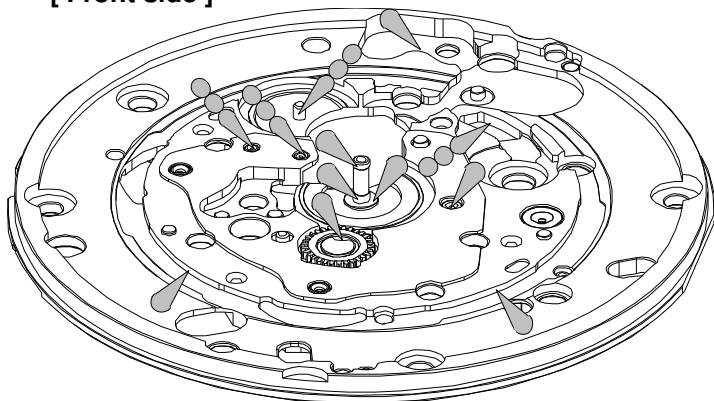

[Back side]

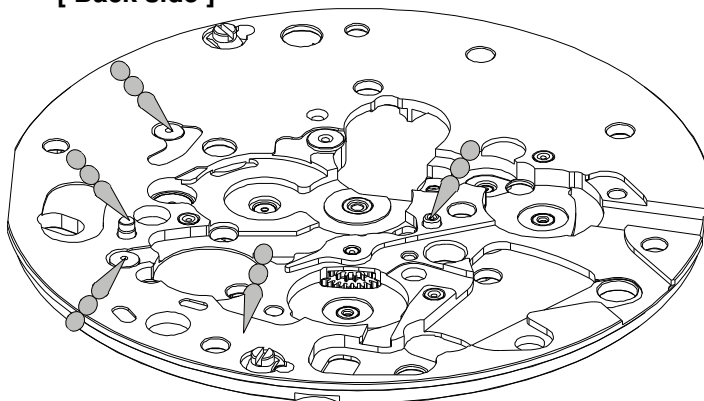

2.The setting position of the spring and lever etc.

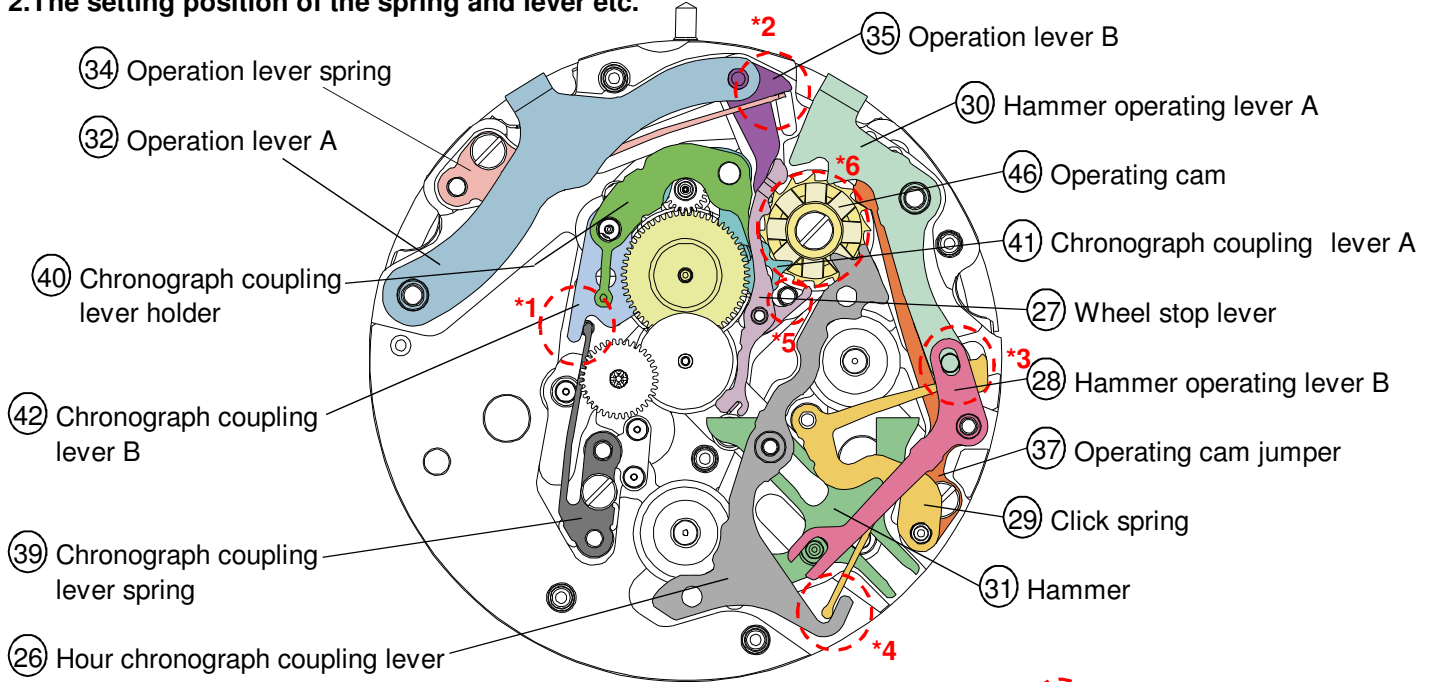

Setting position

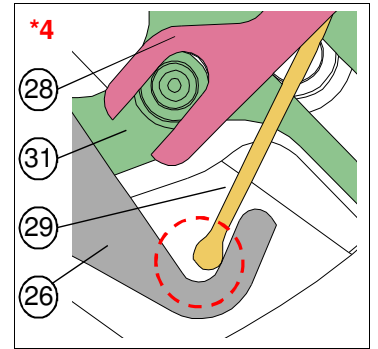
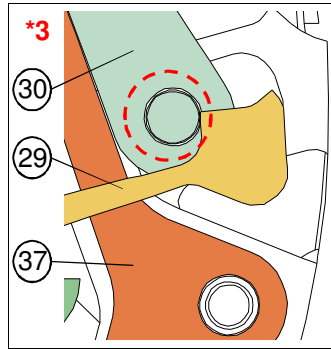
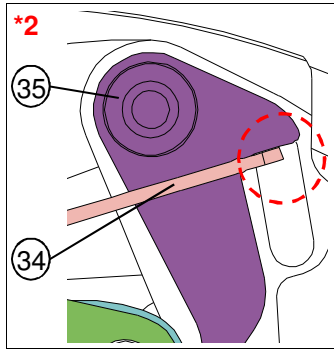
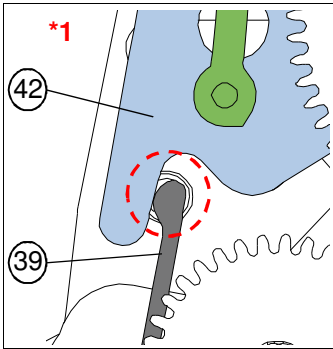

***6 The setting position of the operation cam with and lever.**

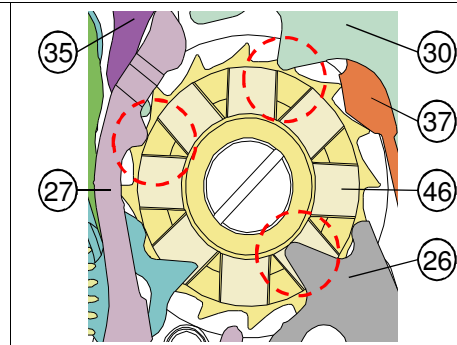
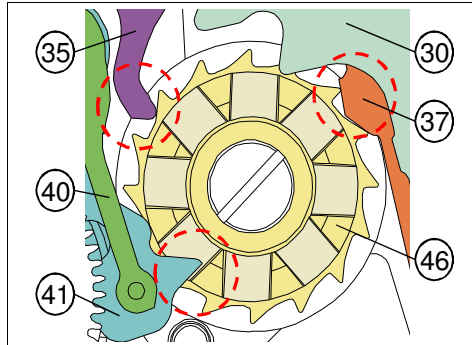
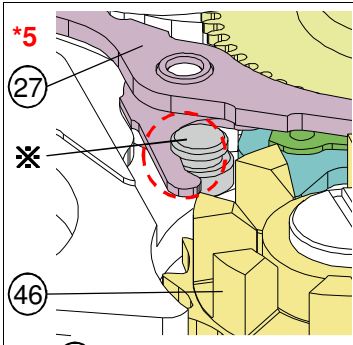

※ (48) Chronograph main plate

Note

After assembling the movement, if it is not possible to button operation, please recheck the spring position.

3. Chronograph coupling A and B setting position

Set chronograph coupling lever A and chronograph coupling lever B between the gears of second counting intermediate wheel.

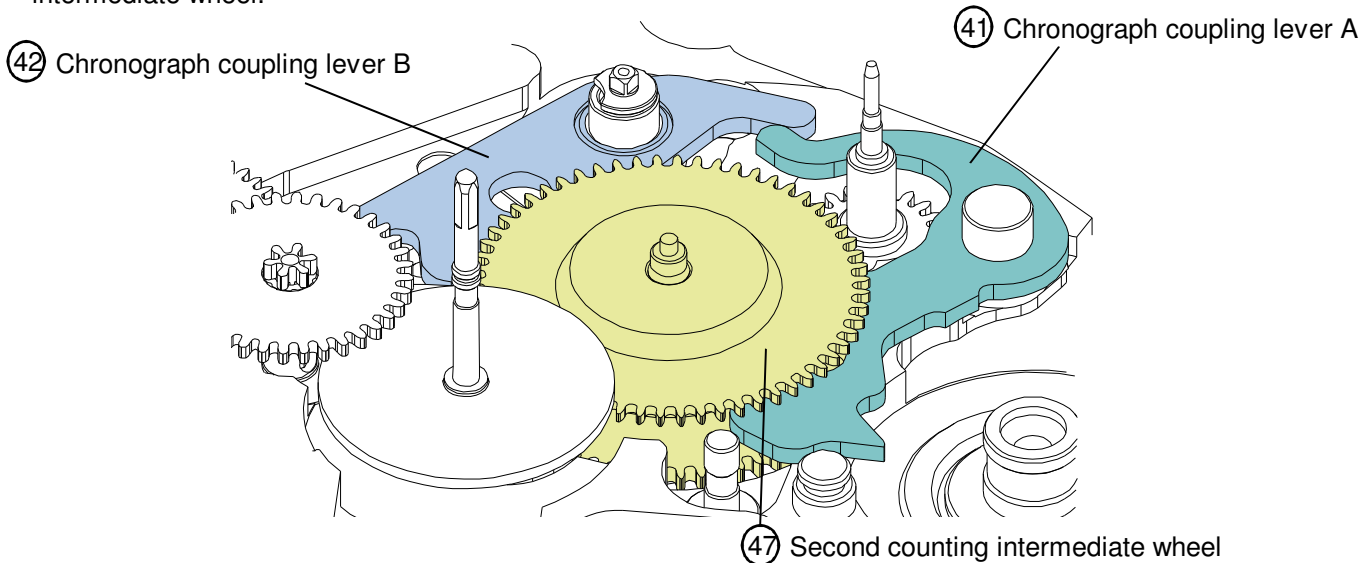

4. Hour chronograph coupling lever setting position

Hour and minute counting wheel need to be inclined when setting.

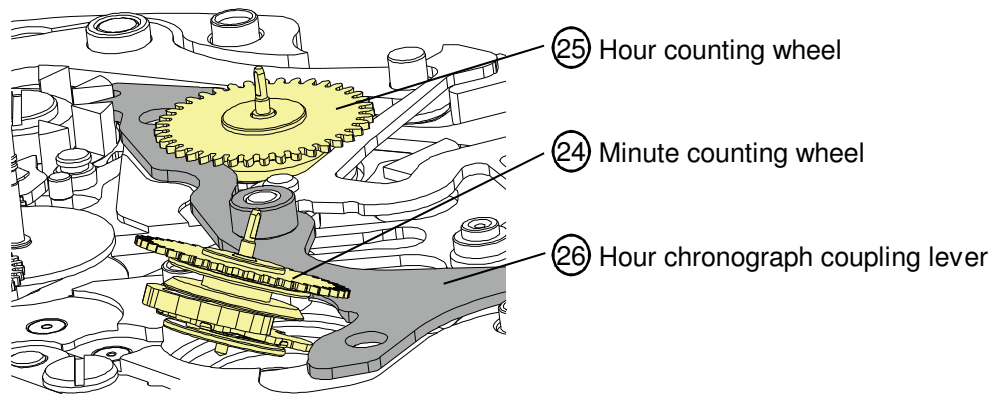

5. Second transmission wheel and minute transmission wheel setting position

· Second transmission wheel and minute transmission wheel should be set parallel to main plate.

· **After detaching, it is prohibited to reuse them.**

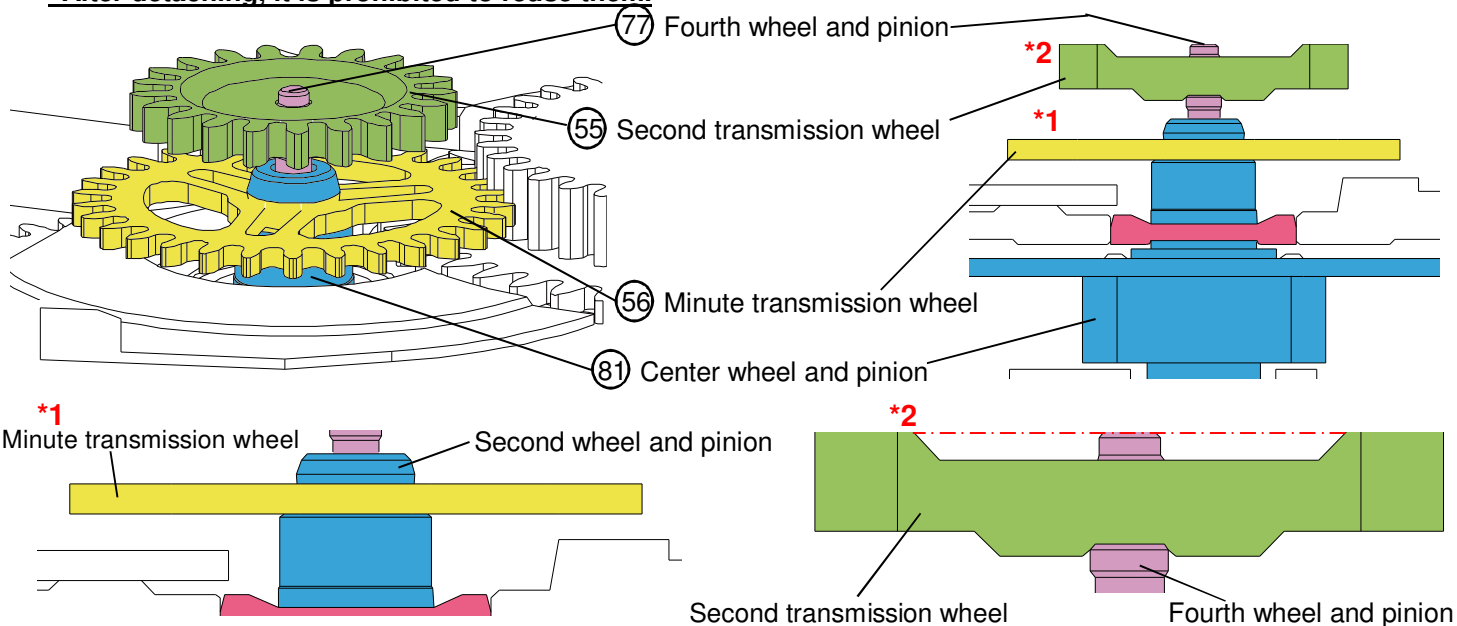

- Make sure to parallel with the main plate.
- But even if it is inclining a little, there is no problem if there are no other parts interfering together.

- The second transmission wheel top surface should be set parallel with the fourth wheel and pinion tip.
- But even if it is inclining a little, there is no problem if there are no other parts interfering together.

6. Disassembling / assembling of the first reduction wheel

<< Disassembling >>

<< Assembling >>

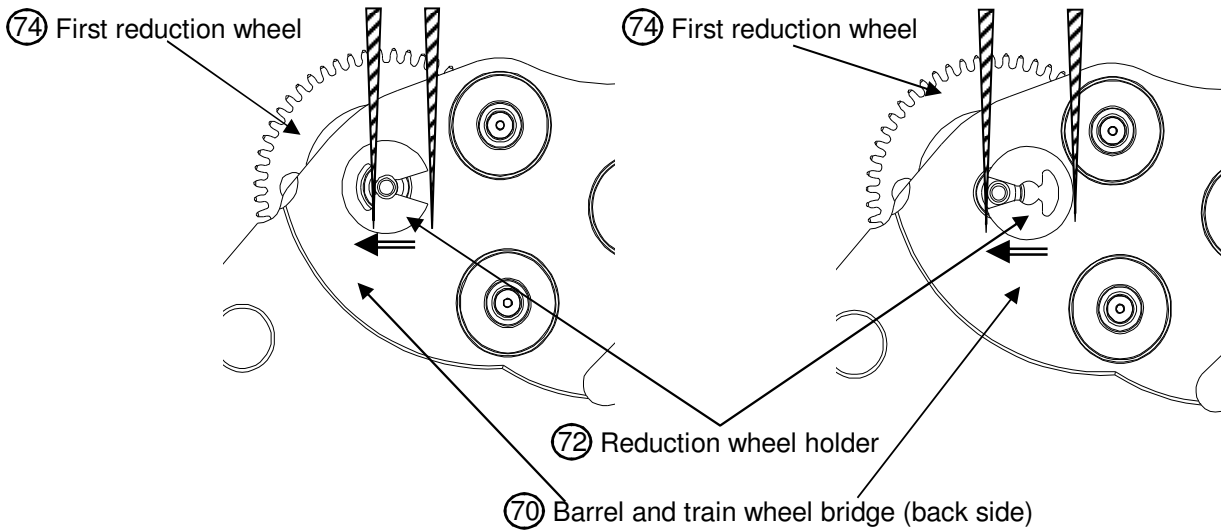

7. Disassembling / assembling of the ratchet sliding wheel spring.

<< Disassembling >>

<< Assembling >>

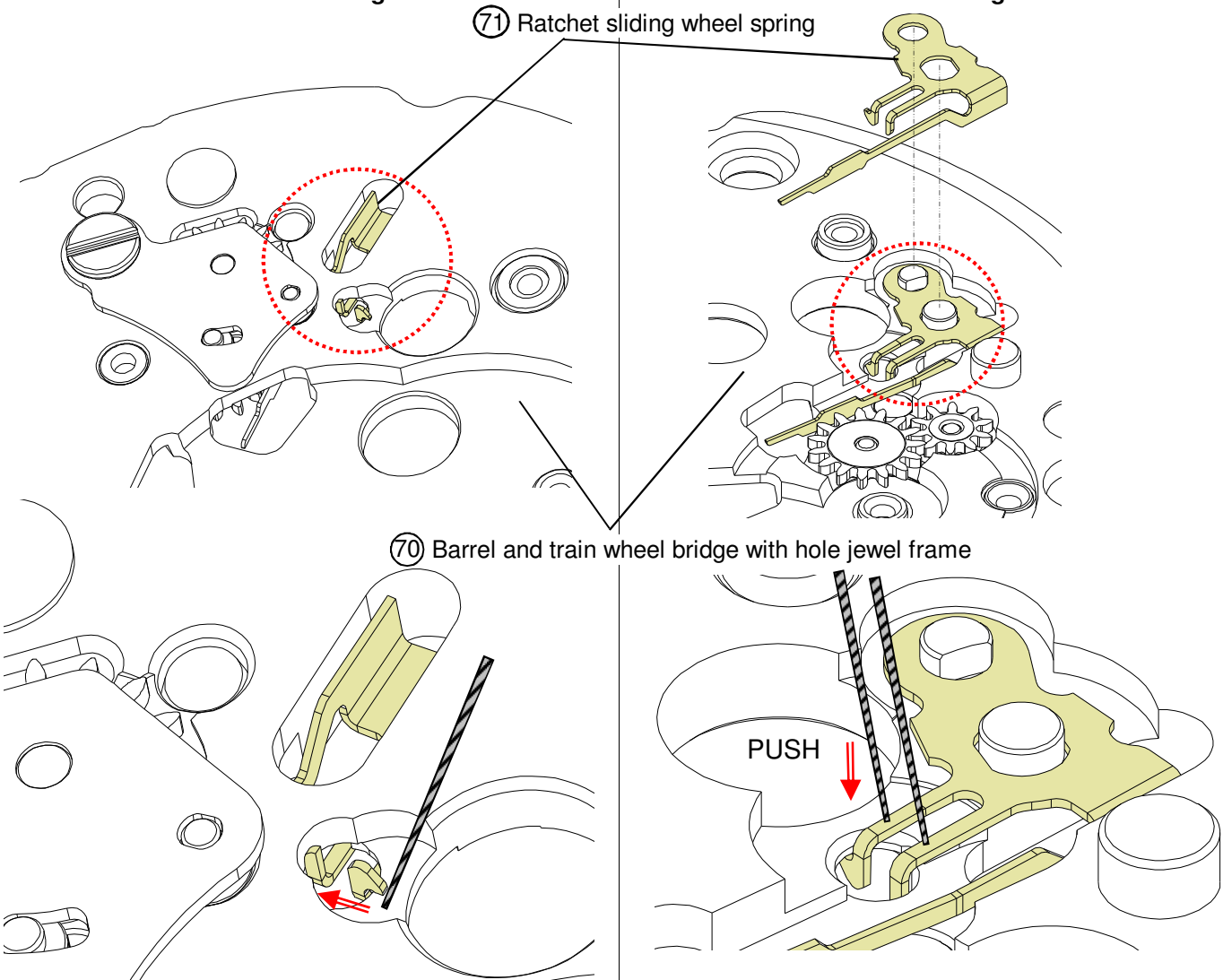

Remove the hook of ratchet sliding wheel spring from barrel and train wheel bridge with hole jewel frame.

The hooks of ratchet sliding wheel spring are hung up on barrel and train wheel bridge with hole jewel frame.

8. Chronograph unit and Base Unit (Disassembling and Reassembling)

Detachment of the chronograph unit and base unit by taking off the screws (4pcs.)

Attachment of the chronograph unit with the base unit.

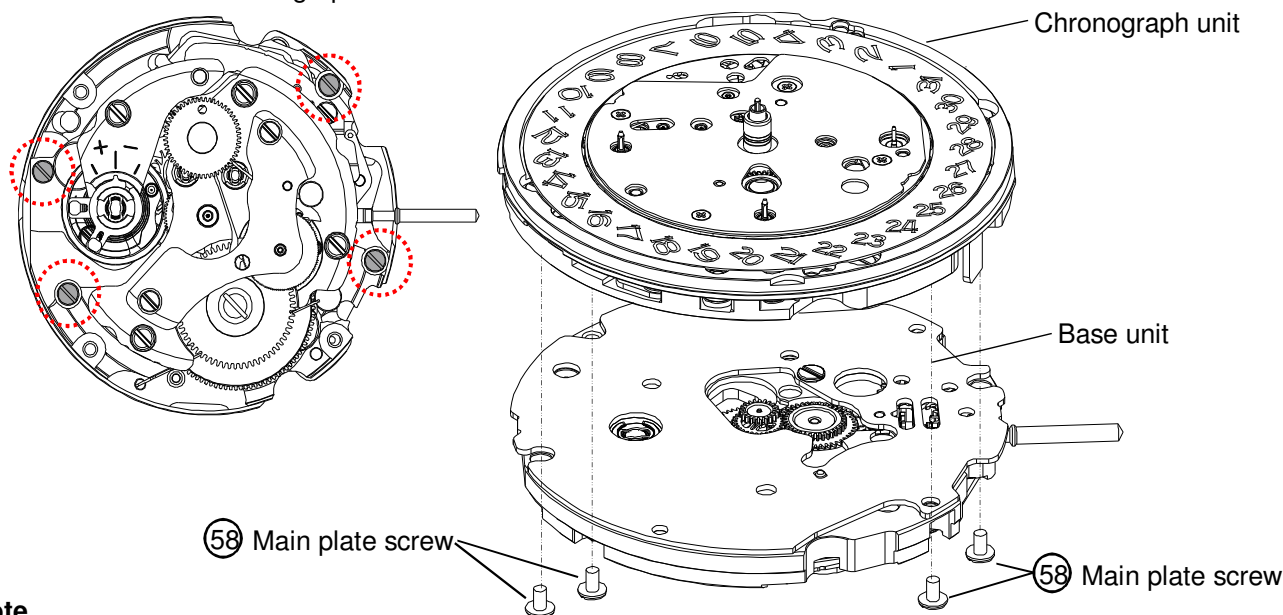

Note

When attaching chronograph unit on base unit, set the push button A in START position, in order to ensure that the following wheels mesh perfectly with one another.

Crown position	Base unit	Chronograph unit	Check point
First position	51 Date corrector setting transmission wheel D	Date corrector setting transmission wheel E	Date display with quick correction
Second position	56 Minutes transmission wheel	Minute wheel pinion A	Hand setting
	55 Seconds transmission wheel	Seconds counter intermediate wheel	Driving

Before attaching the chronograph unit, check that base unit operates correctly.

9. Method to distinguish between dial washers

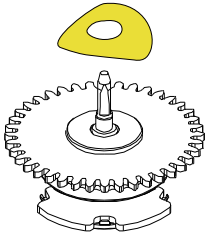
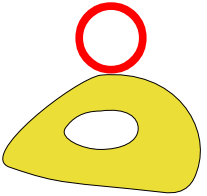
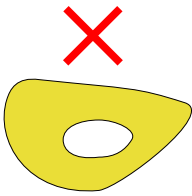
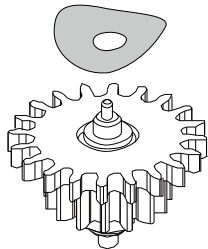
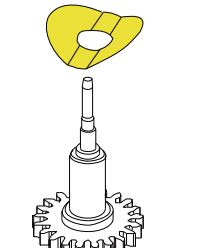
Parts name	Parts code	Set position	Note
20 Dial washer B (X2)	0491 181	 Minute counting wheel Hour counting wheel	· Color of Brass · Handling caution  
19 Dial washer C	0491 182	 Minute counter intermediate wheel and pinion B	· Color of Silver
21 Dial washer D	0491 183	 Second wheel	· Color of Brass

10.Accuracy adjustment

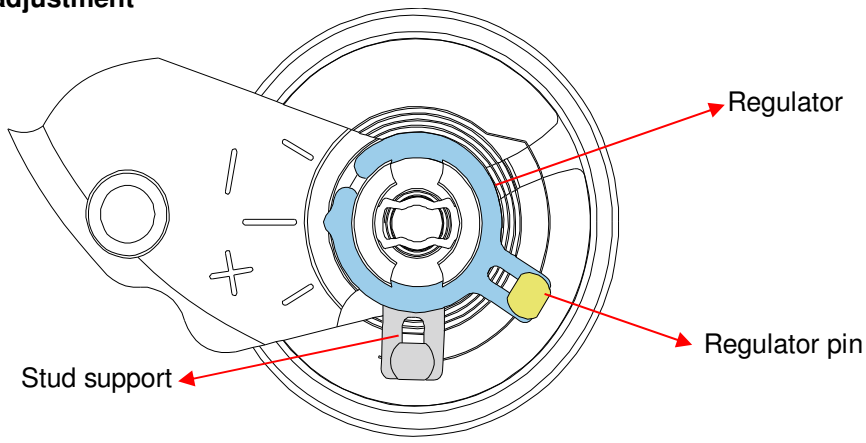

Note:

•Regulator ... Time adjustment

•Stud support ... Beat error adjustment

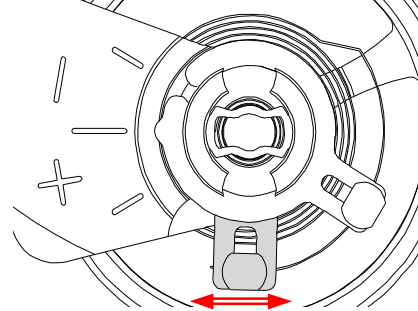
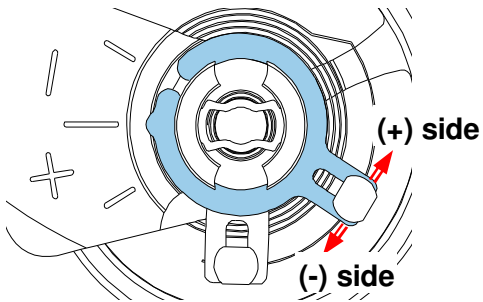

•Regulator pin ... Gap adjustment of balance spring and regulator pin

Anticlockwise rotation

No clockwise rotation

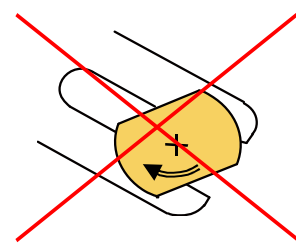
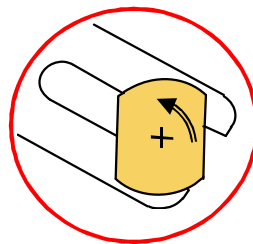
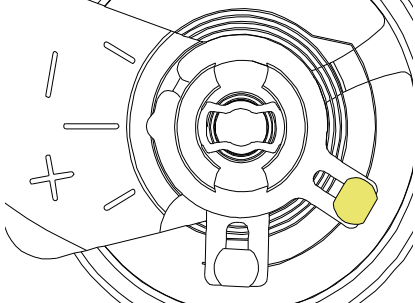

11. Setting position of oscillating weight

- Before assembling oscillating weight.
- Match the center of oscillating weight and winding stem.
- Set the hole of first reduction wheel gear on the imaginary line toward balance bridge guide pin.

Note

This procedure is necessary to maximize the performance of automatic winding.

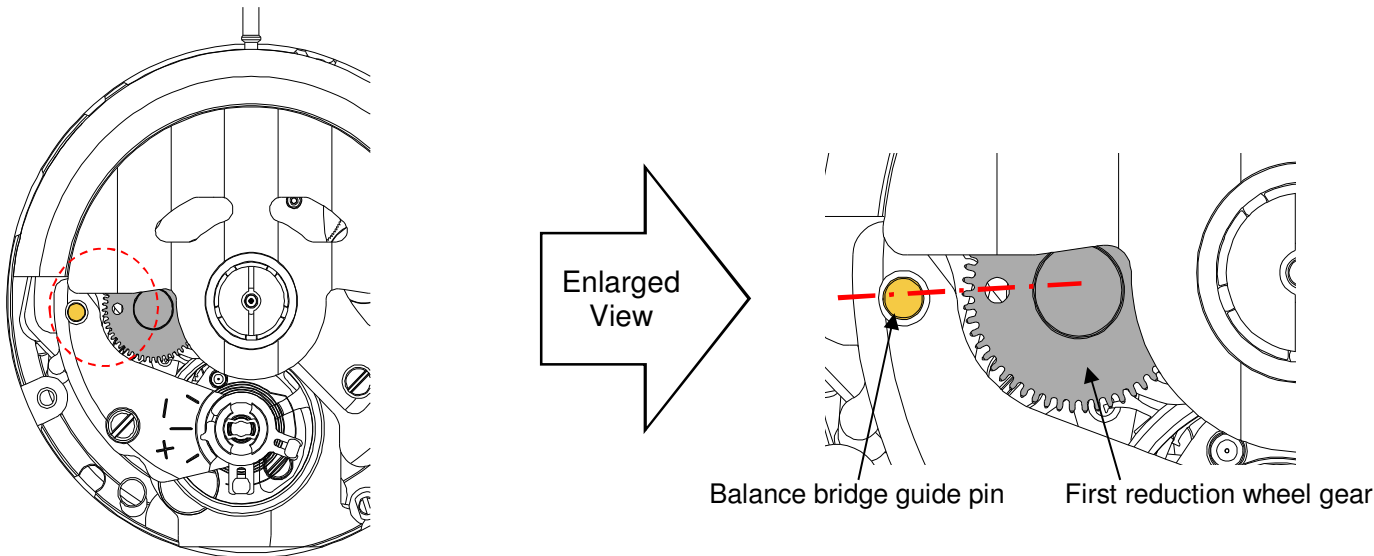

12. To remove winding stem

- 1) Set winding stem to normal position.
- 2) Pull out winding stem while pushing "A".

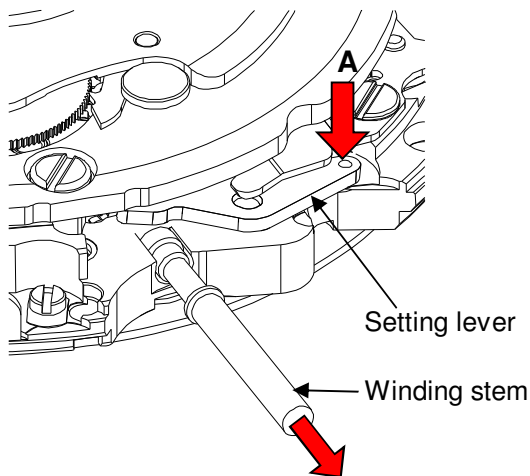

13. To wind up the mainspring

The mainspring would be fully wound up by turning ratchet wheel screw 8 times clockwise.

- Manual winding ... Rotate crown clockwise at normal position by min 55 times. (Equal to ratchet wheel screw 8 times)
- Screwdriver winding ... Turn ratchet wheel screw 8 times clockwise.

[Manual winding]

[Screwdriver winding]

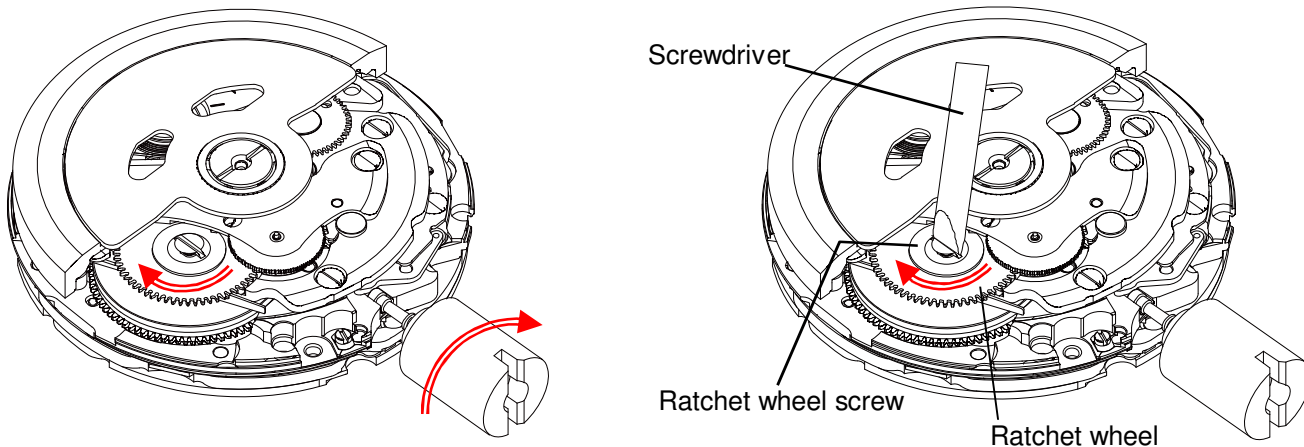

14.How to attach hands

Place the movement directly on a flat metal plate or something similar to attach hands.

We recommend the use of movement holder to attach hands.

For hands attachment, please use a special equipment.

When the movement receives a strong shock, it may be damaged.

Note: Second / minute / Hour chronograph hands setting

- (1) Push button A (chronograph start)
- (2) Push button A (chronograph stop)
- (3) Push button B (chronograph reset)
- (4) After (1)~(3), install the second and hour hands at "12" o'clock, minute hand at "30"minute position.

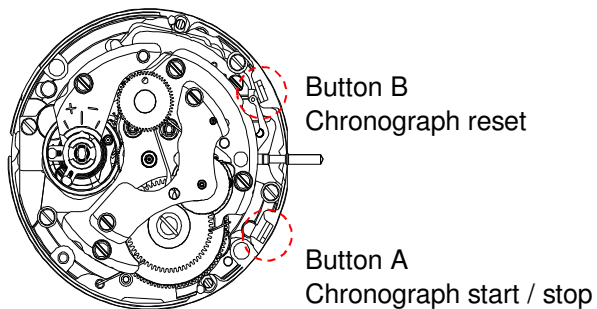
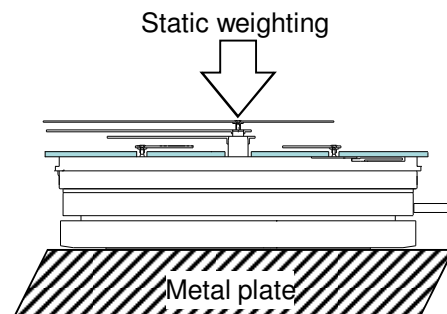

***Do not reuse the chronograph hands once detached. Please change and use new hands.**

Note

During time setting, if the chronograph is started, chronograph hour and minute hands will rotate simultaneously.

This is not a malfunction. Please reset chronograph by pushing button B.

Chronograph hour and minute hands will return to their reset positions.

15.Accuracy measurement condition

Static accuracy : -15~+25 second per day

Measurement conditions

- (1) Measurement should be done within 10~60 minutes after fully wound up.
- (2) Lift angle : 51 deg.
- (3) Measurement position : ① Dial up ② 9 o'clock ③ 6 o'clock
- (4) Minimum measurement time : 20 seconds
- (5) Stabilizing time

Leave the watch for at least 20 seconds to stabilize after you change its measurement position.

DISPLAY AND CROWN / BUTTON OPERATION

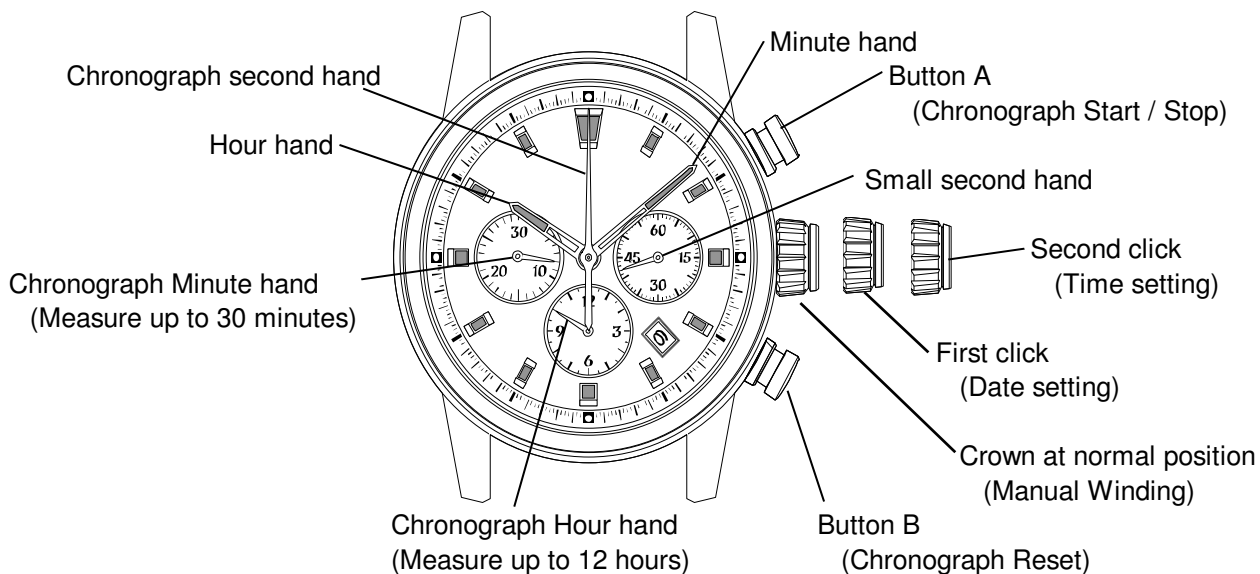

1.How to set the time

- 1) Pull out the crown to the second click position.
- 2) Turn the crown to set hour and minute hands.
(Check that AM / PM is set correctly.)
- 3) Push the crown back into the normal position.

Note

During time setting, if the chronograph is started, chronograph hour and minute hands will rotate simultaneously. This is not a malfunction. Please reset chronograph by pushing button B. Chronograph hour and minute hands will return to their reset positions.

2.How to set the date

- 1) Pull out the crown to the first click position.
- 2) Turn the crown to left for date setting.
*Do not set the date between 8:00 P.M. and 2:00 A.M. as this will cause a malfunction.
- 3) Push the crown back into the normal position.

3.To wind up the mainspring

- 1) Manual winding ... Rotate the crown clockwise at normal position.
 - Fully wound up by turning the crown minimum 55 times.
 - Fully wound up by turning the ratchet wheel screw 8 times.
 It will start to move naturally shaking slightly.
- 2) To wind up with winding machine.
 - Rotary speed : 30 rpm
 - Operating time : 60 minutes

HOW TO USE THE CHRONOGRAPH

[Standard measurement]

Press the buttons in the following order : A → A → B

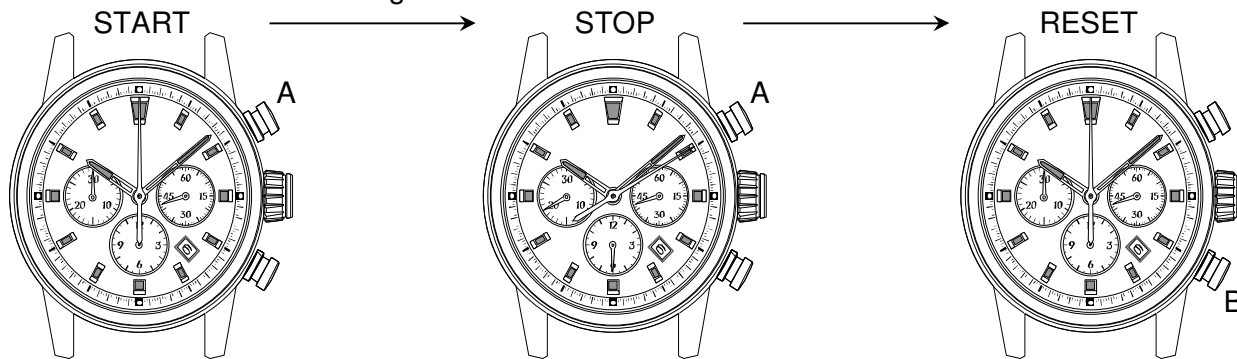

(6 hours 20 minutes 10 seconds)

- Press button A to start chronograph. Chronograph second hand will start moving.

- Press button A again to stop chronograph. Chronograph hands stop to indicate the elapsed time.

- Press button B to reset chronograph. All chronograph hands will be reset to "0" position.

[Accumulated elapsed time measurement]

Press the buttons in the following order : A → A / A ... → A → B

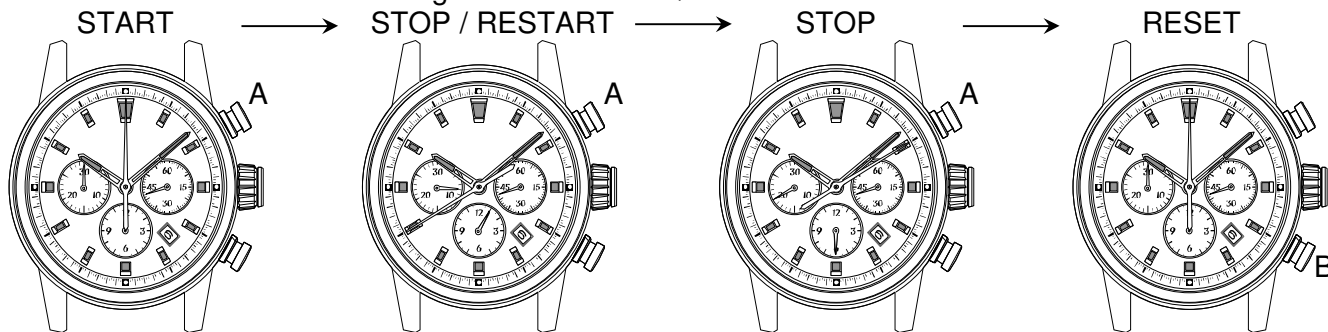

(1 hours 8 minutes 40 seconds) (6 hours 20 minutes 10 seconds)

*Restart and stop of chronograph can be repeated as many times as necessary by pressing button A