

# 7016A

## 1) Specifications

Casing diameter	27.00 mm
Height	6.40 mm
Vibrations per hour	21,600
Automatic winding	
Calendar (Day & date, bilingual changeover mechanism for day indication; crown winding date corrector; push-type day corrector mechanism)	
Chronograph (One revolution in 60 seconds, 30-minute totalizer, 12-hour totalizer, accumulated).	

## 2) Features

7016A Automatic Chronograph is a high-grade watch in which a chronograph mechanism and an automatic winding mechanism are compactly and thinly assembled in a variety of attractive designs. Its structure also is more simplified than the conventional chronographs, thus assuring greatly improved reliability and durability.

- \* Equipped with chronograph hour and minute hands, automatic winding and day and date mechanism the watch enables recording lapsed time in seconds, minutes and hours.
- \* It is the smallest and thinnest multifunction watch on the market.
- \* It has the outstanding reliability and durability in its quality based on the past experiences.
- \* It has a unique design in that chronograph hour and minute hands are attached to a single axle.
- \* As the chronograph mechanism is designed to eliminate adjustments, it ensures easy assembly or disassembly of the watch.

## 3) Disassembly and assembly

Disassemble the watch according to Figures ① →

⑦①





Assemble by reversing the above: Figures ⑦① →

①



## 4) Lubrication

Shown below are the symbols used in sketch to indicate type of oil, degree of lubrication and lubricating points.

### Types of Oil

-  SEIKO Watch Oil S-6
-  SEIKO Watch Oil S-4
-  SEIKO Watch Oil S-3
-  Moebius Synt-A-Lube
-  Moebius Synt-V-Lube

### Oil quantity

-  : Extremely small quantity
-  : Normal quantity
-  : Sufficient quantity



Front

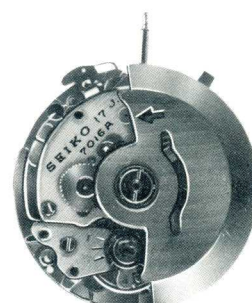

Back

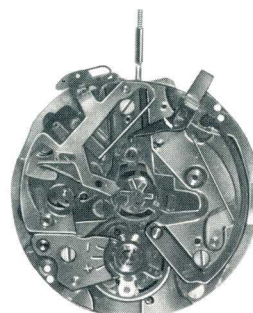

Chronograph Mechanism



Calendar Mechanism

Movement

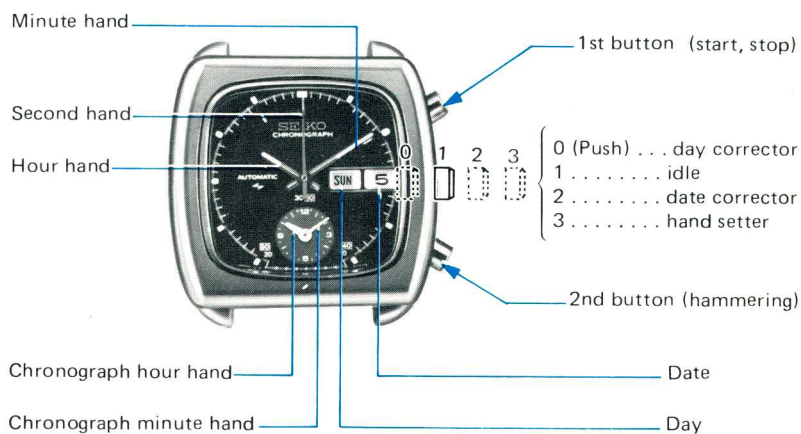

Handling

# 7016A Calendar Mechanism

## Disassembly Precautions

Confirm that watch movement is running.

The watch must be disassembled after the 1st button is pushed to start the movement. The second chronograph wheel may be damaged upon detachment if the watch is disassembled without starting the movement.

## Detachment of Winding Stem.

(a) For square type water-resistant case or monolithic water-resistant case.

With stem at 1st or 2nd stage, pull winding stem while depressing setting lever located in case cut-out at 2 o'clock position.

(b) For back-cover casing

A part of setting lever is visible when winding stem is at the 3rd stage. Pull winding stem while depressing setting lever.

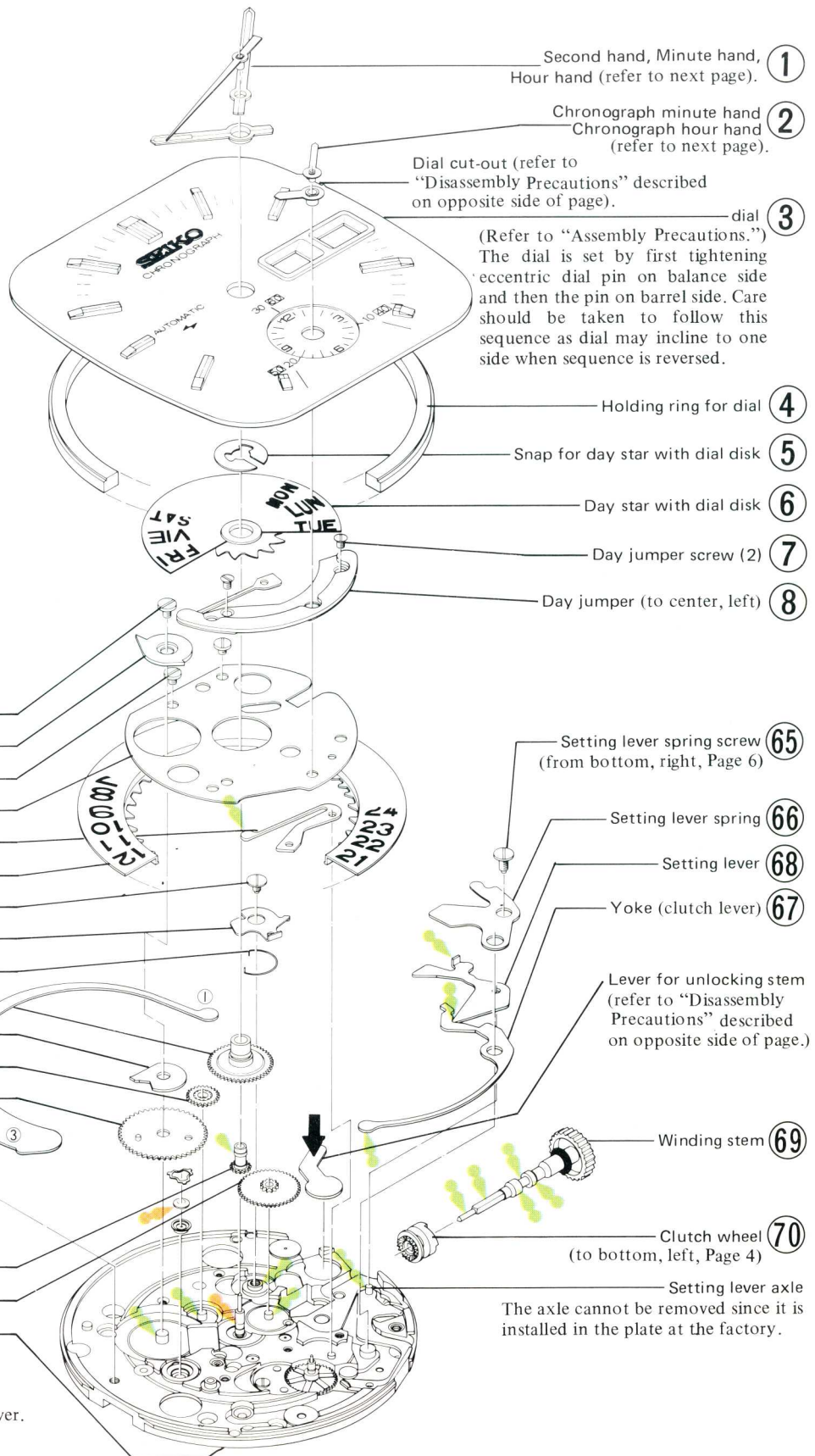

(assembly) (disassembly)

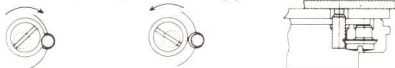

## Assembly and Disassembly Precautions

### Detachment and Attachment of Hands

#### (a) Detachment

Use bow-type tweezers to avoid bending dial. Since the second-hand, chronograph minute-hand and hour-hand are attached firmly, it is necessary that they are removed individually by holding lower end of wheel pipe flange securely with tweezers.



#### (b) Attachment

The chronograph hands must be attached using the movement holder designed exclusively for Cal. 7016.

Warping or slippage of the heart tend to occur when hands are attached without using the movement holder.



1. For attaching, first place movement on the movement holder. Be careful that neither oscillating weight or 1st reduction wheel strikes the thicker diameter pin.
2. Depress 1st button (operating lever) to stop movement; reset hands to zero while depressing 2nd button (hammer) and then depress hands gently into position.
3. Repeat hammering twice and check zero position of hands. When position is not correct, make corrections by turning hands with hammer in depressed position. After hammering, zero position of chronograph minute-hand is judged by releasing finger from button.
4. When zero position is correct, depress hands fully into position. Adequate attachment height of hands is attained by pushing hands to measurements described in sketch below.

5. Next, check zero position of chronograph minute and hour hands.

#### Chronograph hour-hand

With hammer in depressed position, determine whether hand returns to original position when it is lightly moved using tweezers to the left and right over the space of about 30 minutes (one digit to next digit).

#### Chronograph minute-hand

With hammer in depressed position, move hand gently right and left over space of about 2 minutes (half of distance between two digits) and check if hand returns to original position.

#### (c) Exchange of Parts

When hammer or second chronograph wheel are exchanged, check the operation of second heart.

1. Depress operating lever to stop watch movement.
2. Next, move second-hand on 5 seconds position using tweezers and depress hammer.
3. Repeat above hammering.
4. Repeat hammering twice each for 10, 15, 20, 25, 30, 40, and 45 seconds to move second heart smoothly.



#### Attachment of Date and Day Fingers

Be sure to attach date finger while day finger on the other hand is attached with due attention to position of tube for date driving wheel screw. Incorrect changeover of date and day will result when these procedures are not correctly followed.

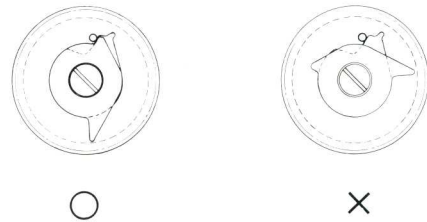

#### Attachment Height of Hands

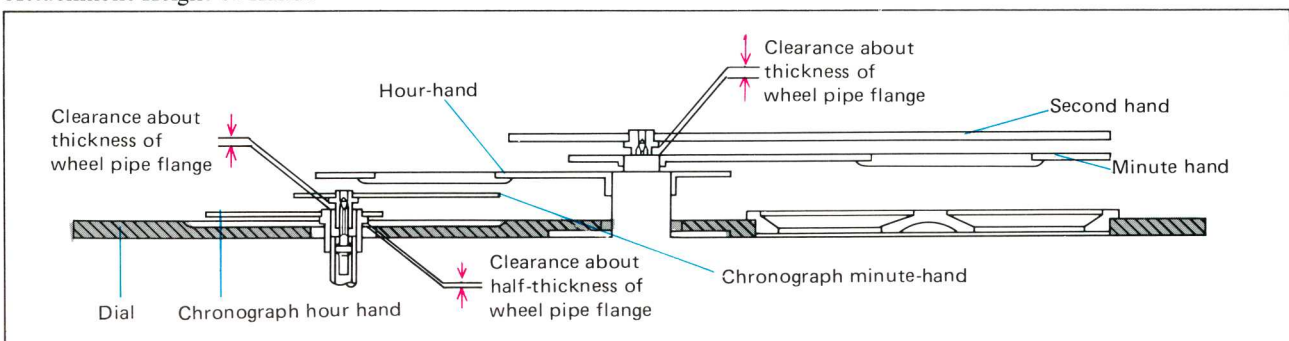

# 7016A Automatic Winding, Chronograph Mechanism

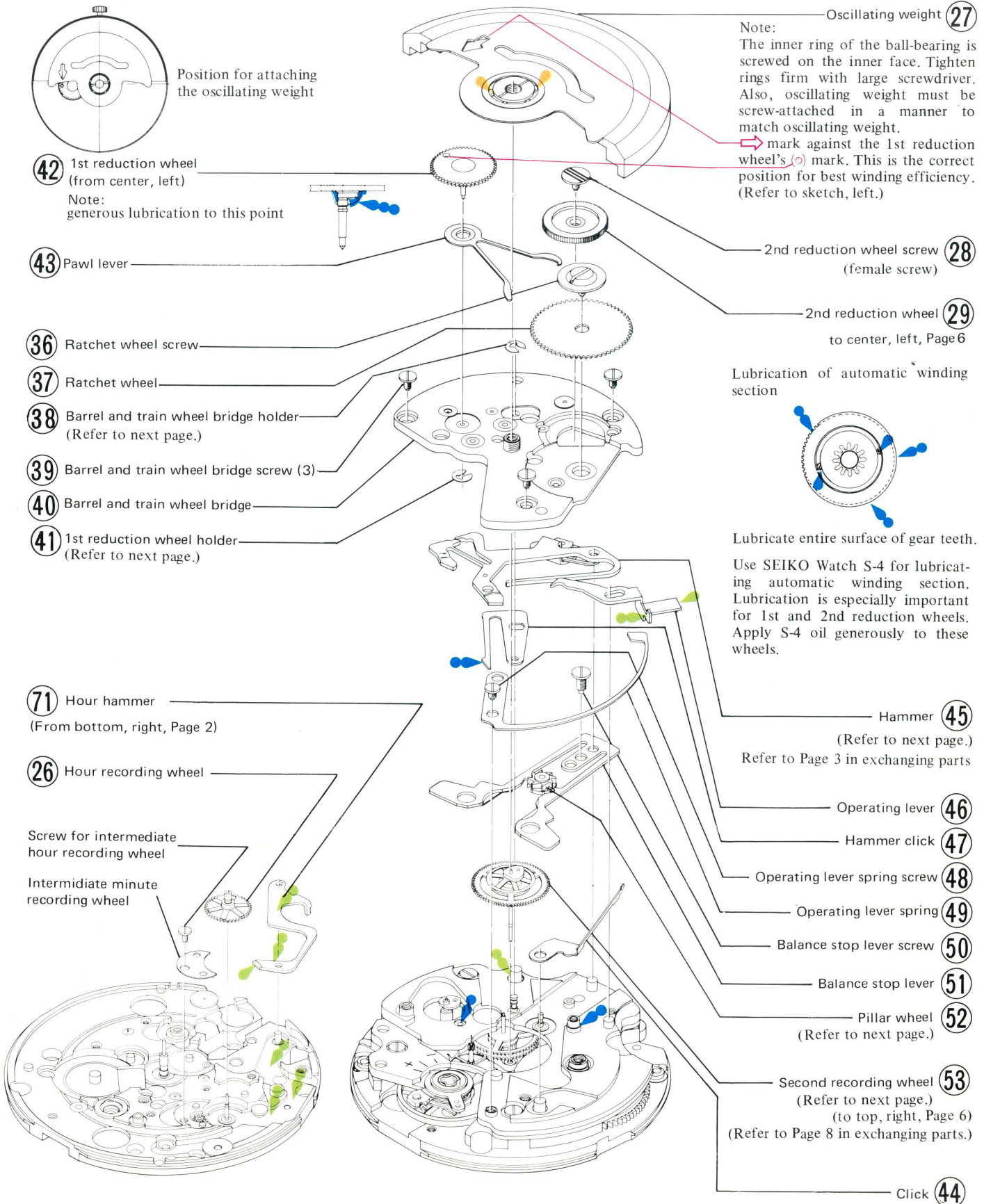

## Assembly and Disassembly Precautions

### Detachment and Attachment of 1st Reduction Wheel Holder and Barrel & Train-wheel Bridge Holder

Insert tip of tweezers from the side in manner shown in sketch below. Be sure not to mistake front and back side of 1st reduction wheel in attaching 1st reduction wheel holder.

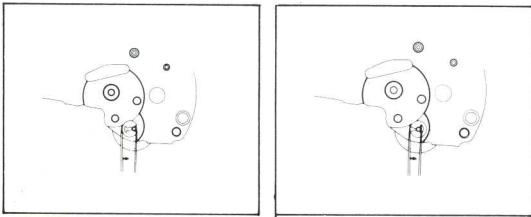

Detachment

Attachment

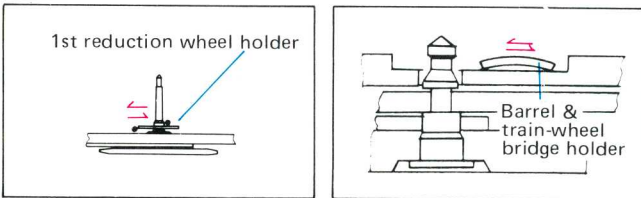

### Hammer

#### Detachment

Detachment must always start with hour hammer ④.

#### Attachment

Begin by bringing hammer spring ① into contact with pin, then hammer pin ② with hammer click. Place into hammer pin ③ and set up hour hammer ④.

#### Position to Lubricate

- ⑤ second heart click surface
- ⑥ minute heart click surface
- ⑦ contact surface with barrel and train-wheel bridge
- ⑧ contact surface with hour hammer
- ⑨ contact surface with 2nd button

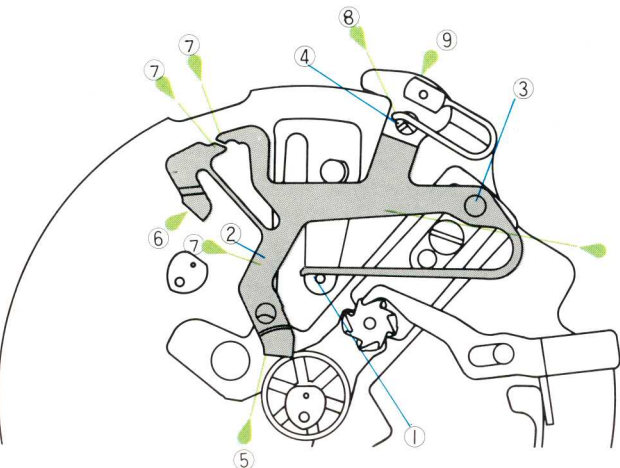

### Balance Stop Lever, Pillar Wheel Detachment and Attachment

As the second recording wheel can be damaged by detaching balance stop lever in closed state (dead condition), it is essential that balance stop lever is detached in open state (during motion) with the pillar wheel linked.

Attach in same manner described above and following same precautions.

#### Position to Lubricate

- ① Four-pronged cam . . . . . 2 portions
- ② Ratchet . . . . . 2 portions

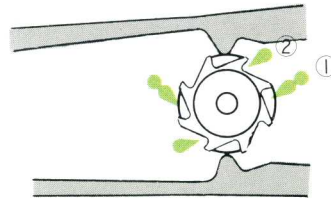

### Lubrication of Second Chronograph Wheel

#### ① 4th Wheel & Pinion

Place second chronograph wheel on staking stool as shown in sketch and lubricate 4th wheel & pinion while pressing it downward with tweezers. Excessive oil moving to pinion is eliminated by rinsing the second chronograph wheel with benzine and then dried.

Lubricate contact surface of clutch ring and spring . . . 3 portions ②

- ③ Upper stem
- ④ Center wheel Arbor
- ⑤ Half-circumference of heart

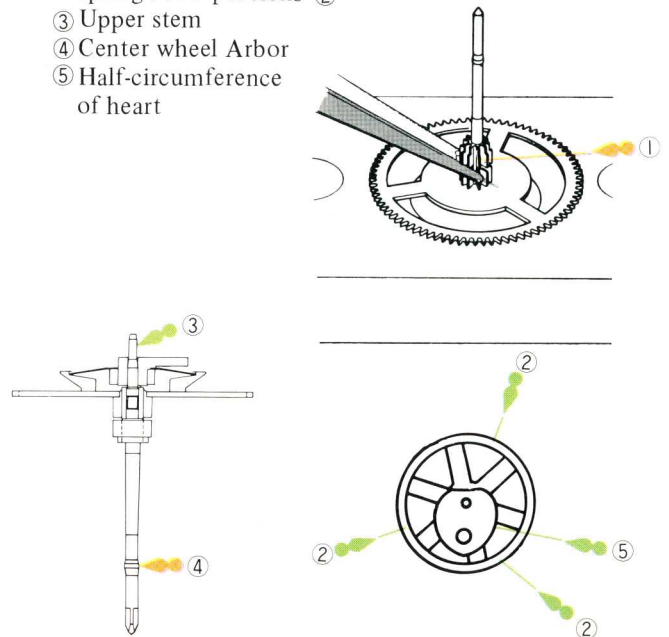

# 7016A Train wheel, Escapement and Regulating Mechanisms

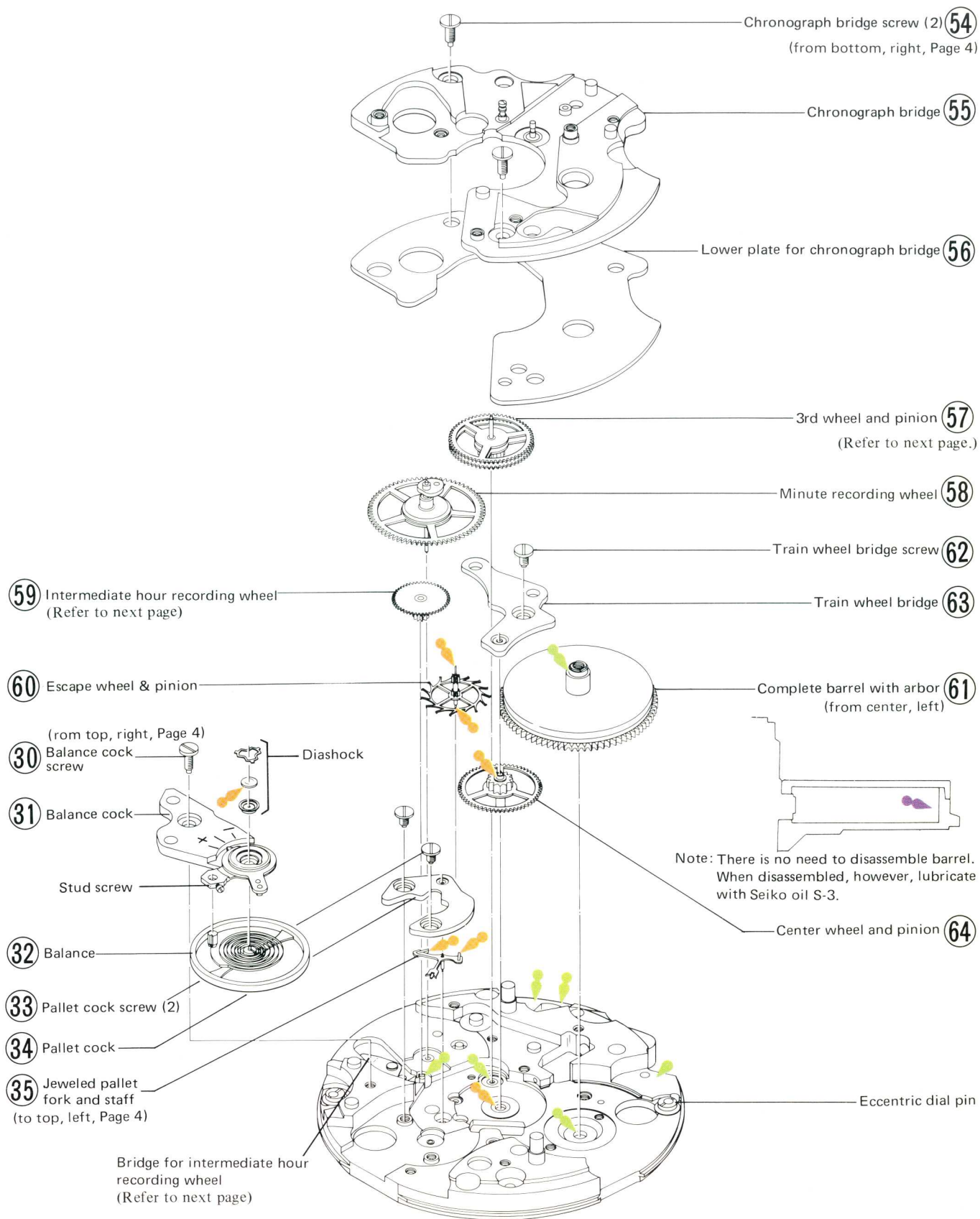

## Assembly and Disassembly Precautions

### Lubrication of Chronograph Bridge

1. lower hole jewel for 1st reduction wheel
2. hammer spring screw
3. contact surface with hammer
4. hammer pin
5. operating lever pin
6. tube for pillar wheel screw

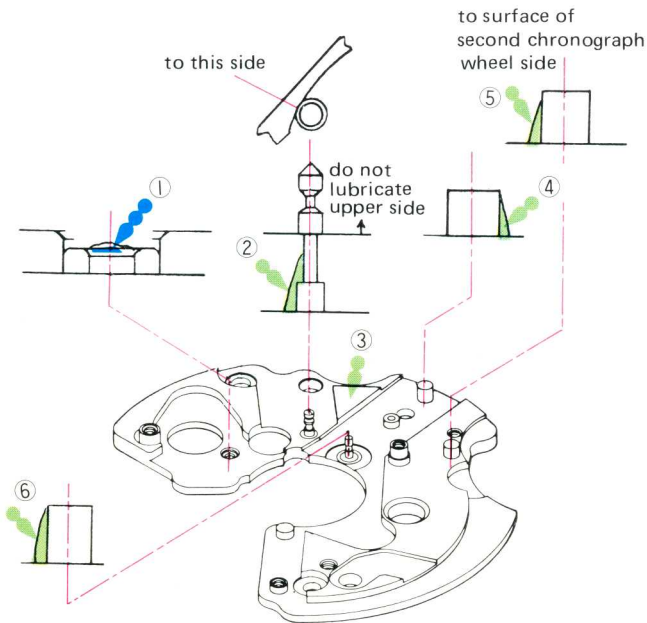

### Lubrication of 3rd Wheel & Pinion

Place 3rd wheel and pinion on staking stool as shown in sketch and lubricate from lubrication-notch side.

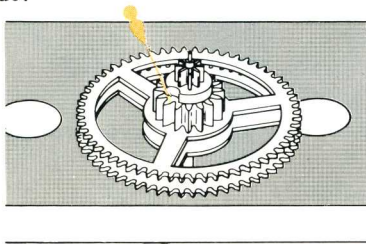

Be careful in holding 3rd wheel and pinion. Pinch arbor or pinion gently.

As horizontal inclination may result, gear section should never be pinched when lubricating wheel.

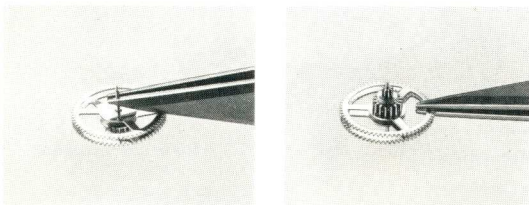

○

×

## Minute Recording Wheel

### Attachment

Be sure that minute heart tip faces balance cock. This is essential to ensure proper setting of chronograph bridge.

### Position to Lubricate

1. upper stem
2. contact surfaces of minute wheel and minute wheel bush . . . 2 positions
3. minute-hand axle . . . 2 positions
4. half-circumference of heart

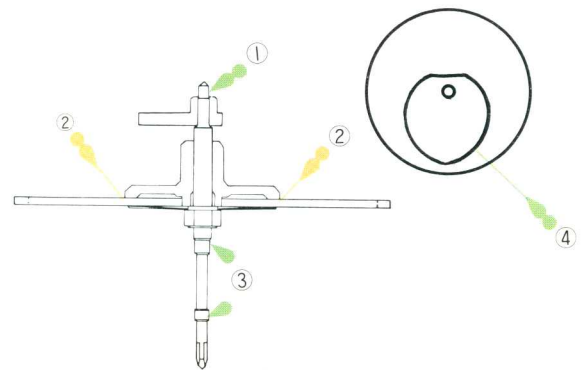

## Detachment and Attachment of Intermediate Hour Recording Wheel

### Detachment

Detach after turning bridge for intermediate hour recording wheel which is inclined toward plate, in the  $\dashrightarrow$  direction.

### Attachment

Set intermediate hour recording in position after confirming that wheel bridge is in  $\dashrightarrow$  direction. Then turn intermediate hour recording wheel bridge to the  $\leftarrow$  direction.

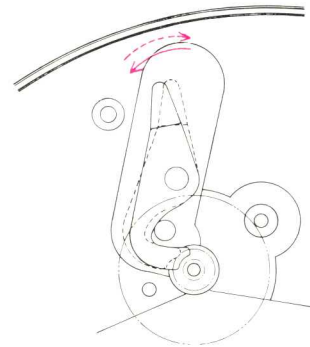

# 7016A Chronograph Mechanism

## 5) Power Transmission of Train wheel

The barrel power is transmitted in sequence shown in Fig. 1

- power transmission when chronograph mechanism is stopped.
- power transmission when chronograph mechanism is operating.

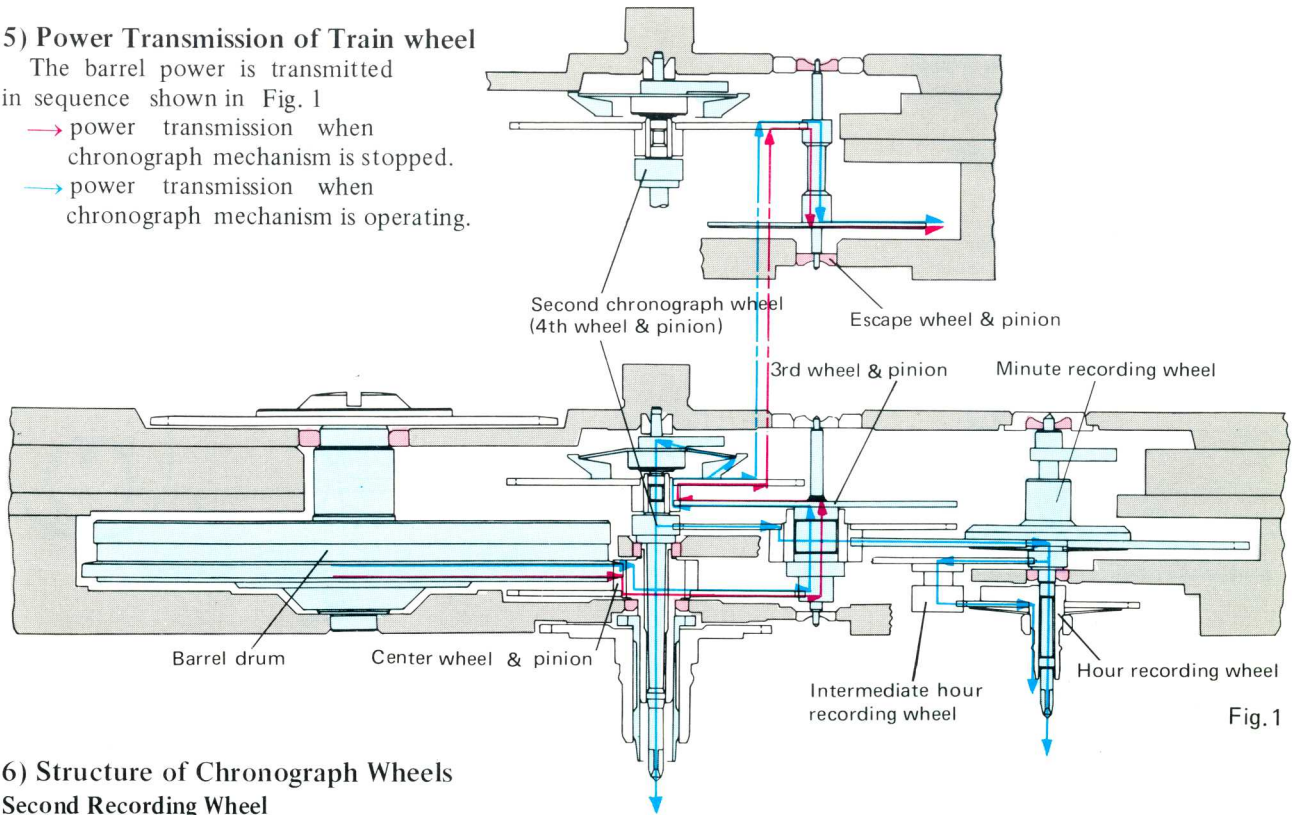

Fig. 1

## 6) Structure of Chronograph Wheels

### Second Recording Wheel

The second recording wheel consists of 4th wheel (sweep second wheel and pinion) and second-hand axle which includes clutch ring, clutch spring, second-heart and second-heart bush.

The 4th wheel and second-hand axle rotate as a single unit when clutch ring is pressed to 4th wheel by the clutch spring.

When clutch ring separates from 4th wheel the second-hand axle stops and 4th wheel rotates independently (Fig. 2)

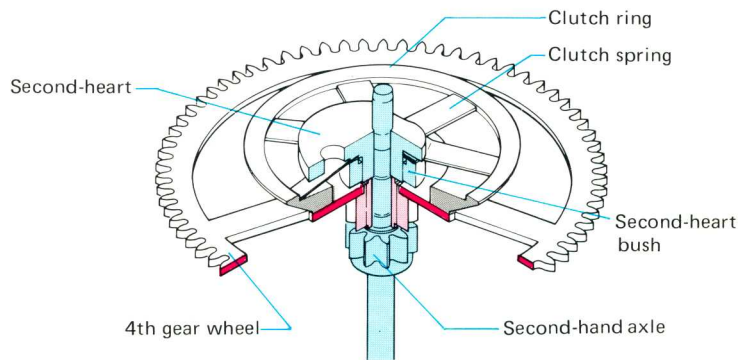

Fig. 2

### Minute Recording Wheel

The minute recording wheel consists of minute gear and minute hand axle which includes minute friction spring, minute gear bush and minute heart.

The minute friction spring presses the minute gear against minute gear bush causing minute gear and minute chronograph hand axle to rotate as a single unit. (Fig. 3)

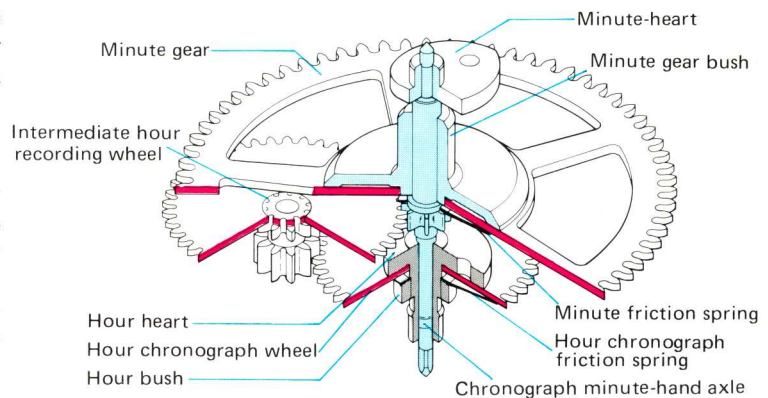

Fig. 3

### Hour Recording Wheel

The hour recording wheel consists of hour chronograph wheel and hour heart which includes hour chronograph friction spring and hour bush.

The chronograph friction spring presses hour chronograph gear to hour heart causing hour chronograph gear and hour heart rotate single unit. (Fig. 3)

# 7016A Chronograph Mechanism

## 7) Operation of Chronograph Mechanism

### Operation Stop

The chronograph mechanism is started by pressing the 1st button (at the 2 o'clock position) which activates the operating lever ① and moves a tooth of the pillar wheel ratchet gear ②. The pillar wheel in the meantime moves the balance stop lever with its arm to activate the second recording wheel ③.

#### (a) Second Recording Wheel

The clutch ring, after separating from the balance stop lever due to the movement above, is pressed to the 4th wheel by the clutch spring and activates the second-hand axle (second-hand).

#### (b) Minute Recording Wheel, Hour Recording Wheel

The rotary movement of the second-hand axle is transmitted to the minute gear through the coupling wheel to activate the chronograph minute hand axle (chronograph minute hand) the rotary action of which is transmitted to the hour recording wheel via the hour chronograph transmission wheel and eventually activates the hour heart (chronograph hour hand). (Refer to Fig. 1).

### Operation Stop

When the 1st button is pressed the operating lever moves a tooth of the pillar wheel ratchet gear to drop the balance stop lever into hollow part of pillar wheel which leads to movements described below.

#### (a) Second Recording Wheel

The clutch ring is lifted by the balance stop lever and separates from the 4th wheel, thus stopping the action of the second-hand axle (second-hand).

#### (b) Minute Recording Wheel, Hour Recording Wheel

The entire chronograph mechanism cease to operate simultaneously with the stop of the second-hand axle. (Refer to Fig. 2.)

### Accumulations

The chronograph mechanism returns the condition shown in Fig. 1 when the 1st button is depressed again in the stopped state, at which moment the second-hand, chronograph minute-hand and chronograph hour-hand start to function again to record the accumulated time.

### Hammering

The hammer ① starts operating when the 2nd button (the one in the 4 o'clock position) is depressed. It activates the second-heart ② and minute-heart ③ and turns back the second-hand and chronograph minute-hand to zero.

The chronograph hour-hand also is returned to zero when the hour hammer ④ linked with the hammer strikes the hour heart ⑤ (Refer to Fig. 3.)

At the aberrations between assembly parts are fully absorbed by the hour hammer spring ⑥ and hammer's minute spring section ⑦, adjustment of the hammer which is inevitable in assembly and repair of conventional stop-watches and chronographs are entirely eliminated in the 7016A chronographs. (Refer to Fig. 3.)

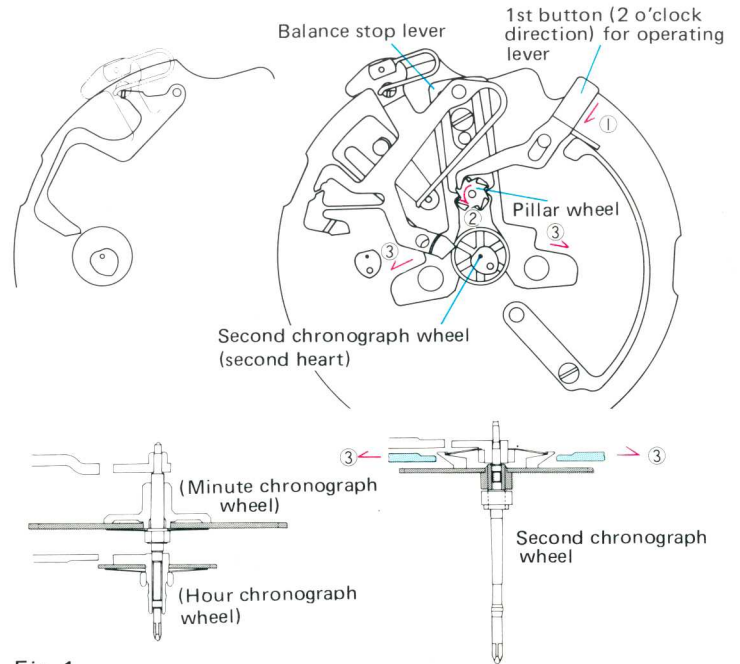

Fig. 1

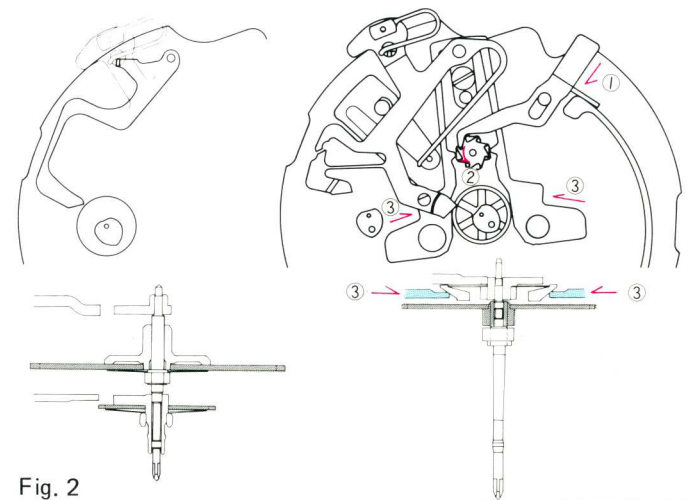

Fig. 2

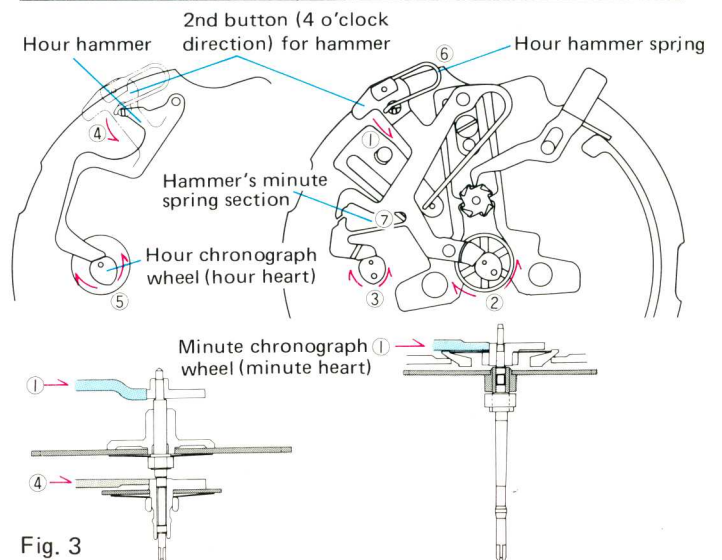

Fig. 3