

# 6138A Automatic Chronograph

## 1) Specifications

Casing diameter	27.00mm
Height	7.90mm
Vibrations per hour	21,600
Automatic winding (with auxiliary hand winding)	

Calendar (Day & date, Bilingual change-over mechanism for day indication, Rotary type instant day & date setting device)

Chronograph (Second, hour hand – 12 hour totalizer; minute hand – 30 minute totalizer, accumulated)

## 2) Features

- An-advanced automatic winding chronograph
- Easy-to-use, regular chronograph mechanism
- SEIKO's special clutch mechanism without starting/stopping errors
- Simplified structure and automatic winding by the stabilized pawl lever system
- Day and date instant setting device operated simply by revolving the crown
- Bilingual change-over mechanism for day indication selectable by preference
- Auxiliary hand winding device instantly usable for measuring time
- External devices with many functions

## 3) Disassembly and assembly

Disassemble the watch according to Figs.

①→⑨①

Assemble by reversing the above: Figs.

⑨①→①

Installation of the automatic winding mechanism varies as compared with conventional watches.

The automatic winding mechanism should be installed after setting the movement with hands in the case for adjusting chronograph mechanism and setting hands works.

## 4) Lubrication

Colored symbols in the illustrated figures indicate the types of oil, its quantities to be applied, and lubricating points.

### Types of oil:

- Moebius Synt-A-Lube
- Seiko watch oil S-4

### Oil quantity

- Extremely small quantity
- Normal quantity
- Sufficient quantity
- ⊗ Oil must not be applied.

Note: Unindicated portions do not require lubrication.

## 5) Checking and adjusting

Refer to 6139A Technical Guide for checking and adjusting items of second and minute chronograph mechanism.

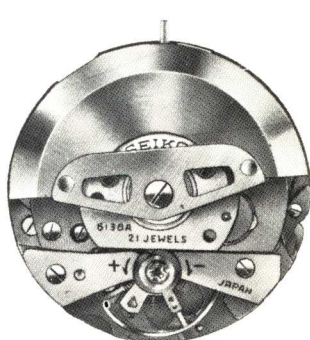
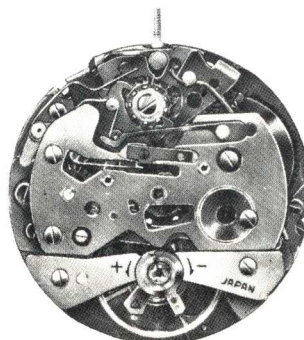
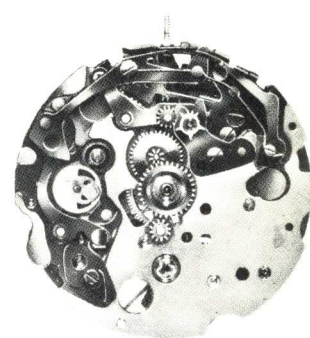

Movement

# 6138A Automatic Winding Mechanism

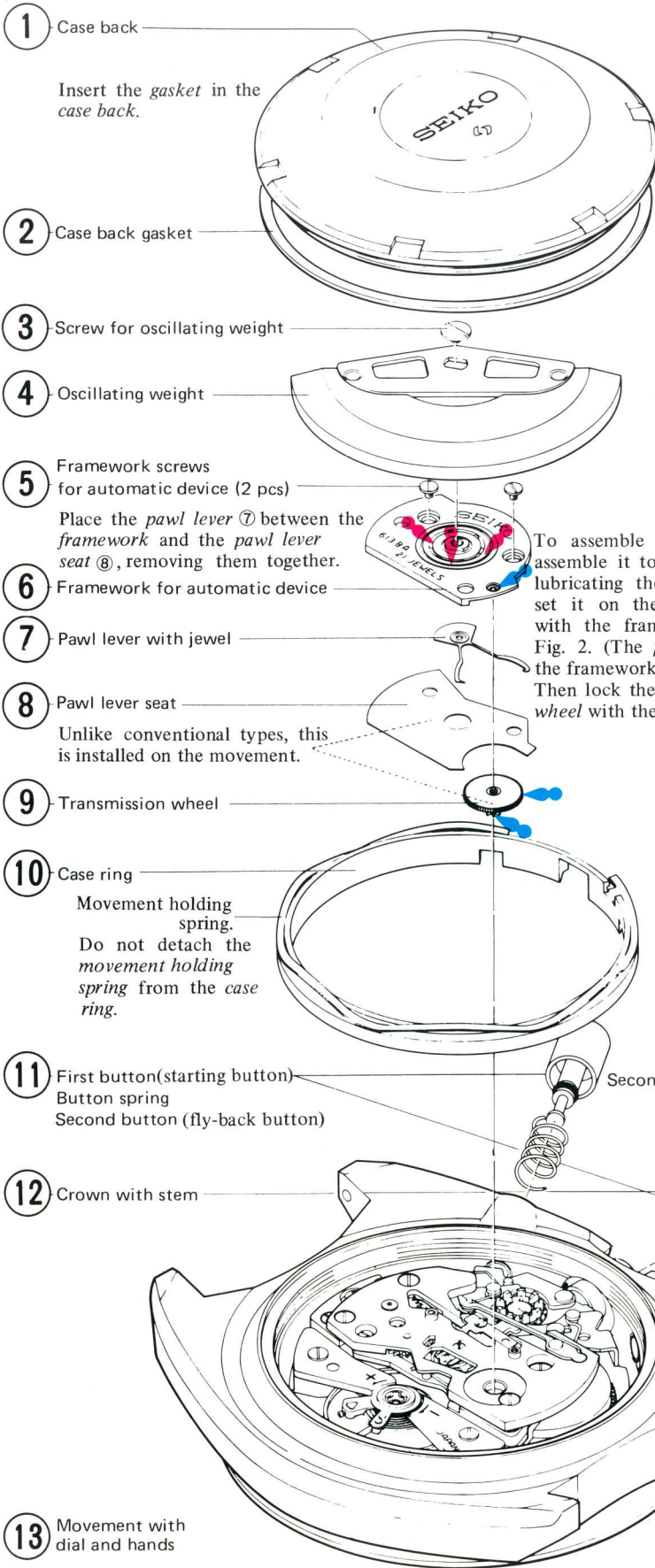

Structure of Button Portion

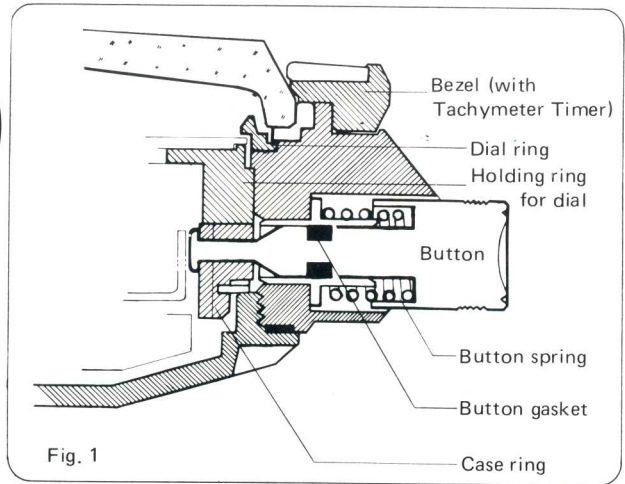

To assemble the *pawl lever*, first assemble it to the framework after lubricating the *eccentric pin*; then set it on the movement together with the framework, as shown in Fig. 2. (The *pawl lever* coheres to the framework by oil adhesion.) Then lock the teeth of *transmission wheel* with the *pawl lever*.

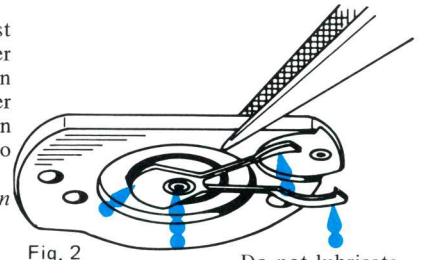

Do not lubricate the top of the pin.

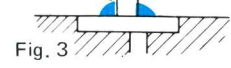

The two buttons ⑪ must be depressed simultaneously to either remove or insert the case ring.



# 6138A Calendar Mechanism

(Installing the second hand and chronograph minute and hour hands)

1. At the fly-back position, tentatively set the hands on the "0" position.
2. Then repeat fly-back operation to ensure the "0" position. If the hands fail to resume correct position, adjust the hands while depressing the fly-back button.

However, since the fly-back lever of the chronograph hour hand has a springing characteristic, it prevents the hand from rotating while the hammer button is depressed. Consequently, reinstall the chronograph hour hand so that it coincides with "0" position.

3. Completely push in the hands at the point where they correctly indicate the "0" position.



**NOTE:**  
The second hand axle is cut as shown in the diagram. If the second hand is turned by force after completely depressing it to the bottom, the hand will loosen.

SEIKO provides a handy Movement Holder S-500 to facilitate hand-setting.

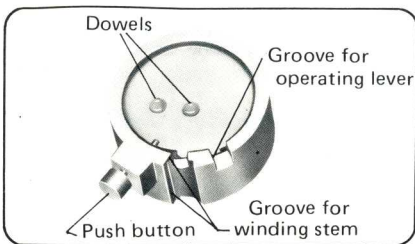

**NOTE:** However, since this movement holder is originally for 6139A, the movement is slightly raised when using this holder for 6138A. If the dowels on the holder are scraped off, it is impossible to use for 6139A.

28 Date dial guard screw

29 Date dial guard

When disassembling and assembling the date dial guard, perform carefully to avoid breaking the chronograph hour hand pin. \*2

30 Date dial

31 Date jumper

32 Date driving wheel screw

33 Day finger

34 Date finger

35 Date driving wheel

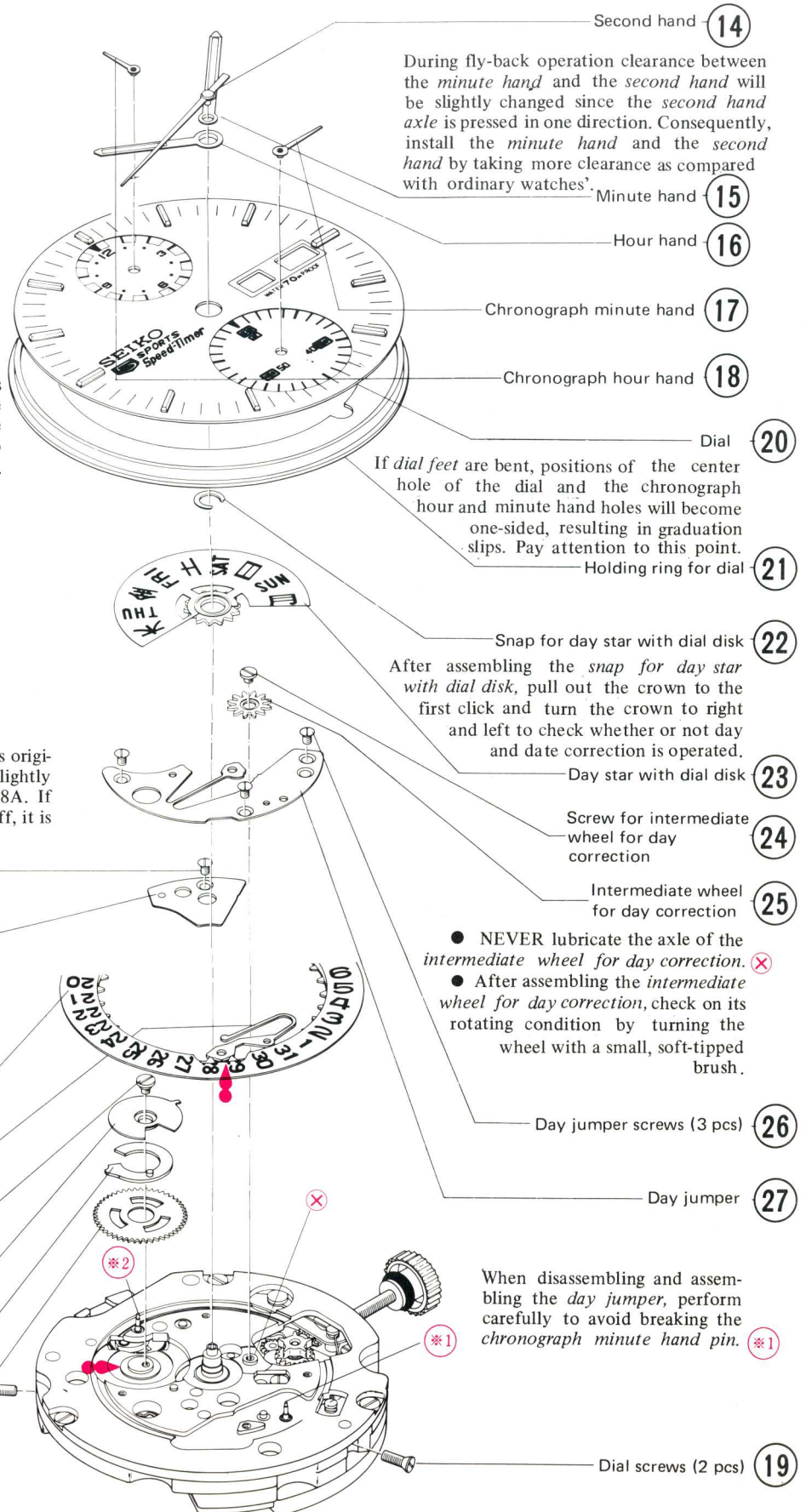

# 6138A Chronograph Mechanism

Explanations on this page are for the nucleus of 6138A. Sufficiently check and adjust the assembled movement.

1. Items to be checked before assembling the jewelled pallet fork and staff, after setting the chronograph bridge.

- 1) Confirm that free running force is transmitted unaffectedly. Even though no roll back motion exists, as long as it functions smoothly there is no problem. And at the same time check the performance of starting and stopping actions of the hour recording wheel by turning over the movement.
- 2) Check for meshing condition of the first and second coupling levers (Refer to 6139A-8).
- 3) Check clearance between the second coupling lever and the intermediate hour recording wheel stop lever pin and their actions.

When stopping, clearance must exist between the second coupling lever and the intermediate hour recording wheel stop lever pin; when starting, the second coupling lever must push and move the intermediate hour recording wheel stop lever pin.

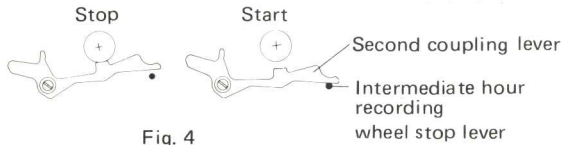

Fig. 4

Should they malfunction, adjust them by turning the second coupling lever axle eccentric pin. In this case, perform this adjustment while observing the delicate clearance between the second coupling lever and the clutch lever.

2. Items to be checked after assembling the balance

- 1) Check for strength and height of the minute recording jumper (Refer to 6139A-8).
- 2) Check for meshing position of the chronograph finger (Refer to 6139A-9).
- 3) Check for contacting condition of the hammer and hearts (Refer to 6139A-10).

- 36 Balance cock screws (2 pcs)
- 37 Balance cock
- 38 Balance complete with stud
- 39 Pallet cock screws (2 pcs)
- 40 Pallet cock
- 41 Jewelled pallet fork and staff

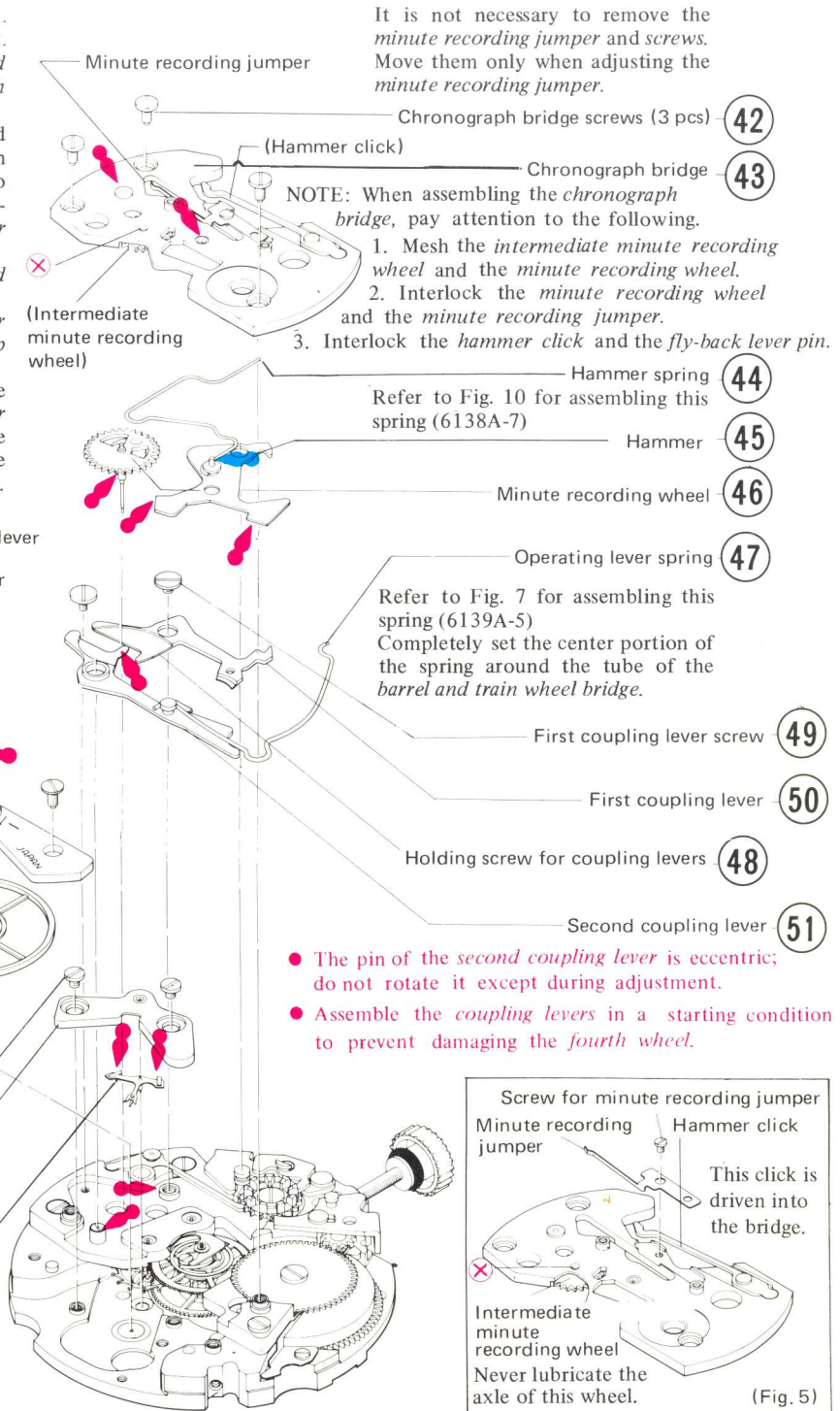

It is not necessary to remove the minute recording jumper and screws. Move them only when adjusting the minute recording jumper.

NOTE: When assembling the chronograph bridge, pay attention to the following.

1. Mesh the intermediate minute recording wheel and the minute recording wheel.
2. Interlock the minute recording wheel and the minute recording jumper.
3. Interlock the hammer click and the fly-back lever pin.

Refer to Fig. 10 for assembling this spring (6138A-7)

Refer to Fig. 7 for assembling this spring (6139A-5) Completely set the center portion of the spring around the tube of the barrel and train wheel bridge.

- The pin of the second coupling lever is eccentric; do not rotate it except during adjustment.
- Assemble the coupling levers in a starting condition to prevent damaging the fourth wheel.

## Train wheel (process of force transmission)

Transmission of force when chronograph mechanism is started.  
Transmission of force when chronograph mechanism is stopped.

When the minute and second chronographs are started, the force is transmitted to both chronograph and train wheel by the action of the clutch, and when the chronographs are stopped, the force is transmitted only to the train wheel. When the hour chronograph is started, the force is transmitted from the barrel → friction spring for intermediate hour recording wheel → intermediate hour recording wheel → hour recording wheel. When the hour chronograph is stopped, force transmission to the hour recording wheel is stopped by a slip of the friction spring for intermediate hour recording wheel.

## Center chronograph wheel (Fourth wheel)

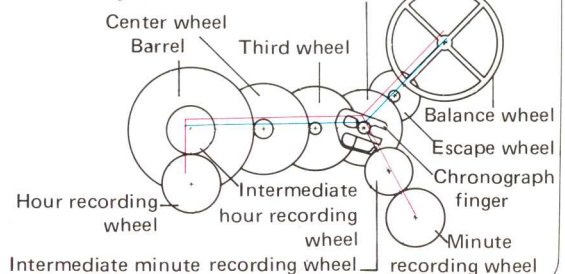

# 6138A Train Wheel

## Lubricating the pillar wheel

To prevent chipping, install the pillar wheel on the barrel and train wheel bridge before assembling the latter.

Assemble the pillar wheel to the bridge while interlocking with the pillar wheel jumper.

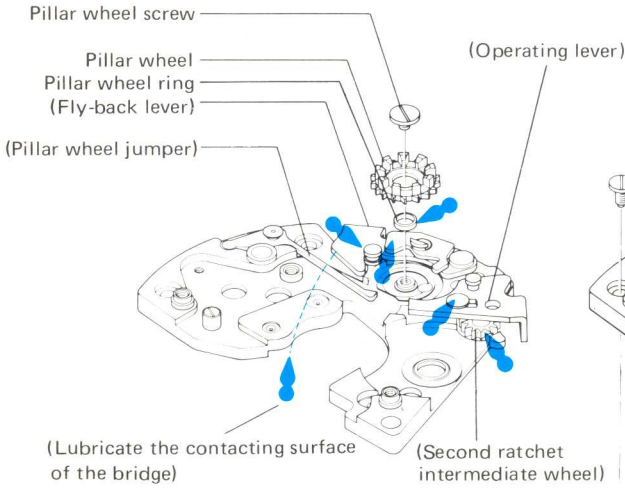
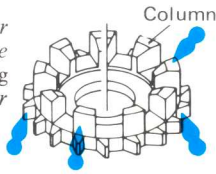

Operating lever, fly-back lever, pillar wheel jumper, second intermediate ratchet wheel, and crown wheel are driven into the barrel and train wheel bridge.

Dial side of the barrel and train wheel bridge

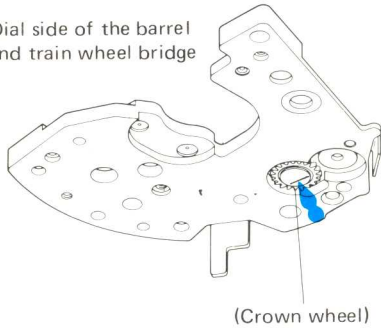

(Crown wheel)

## Lubricating the fourth wheel

Apply oil between the clearance of the fourth wheel pinion and the axle.

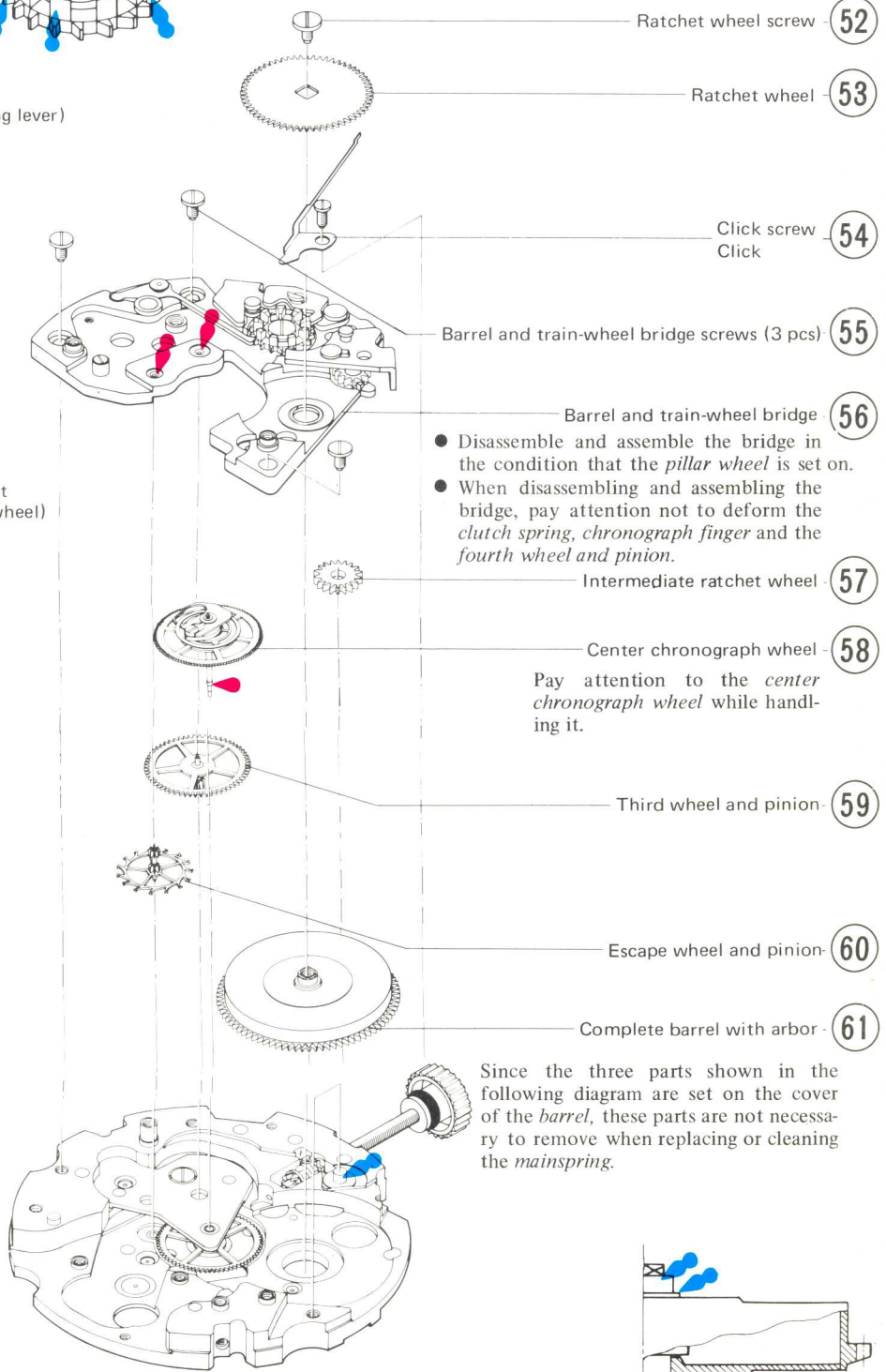

- Disassemble and assemble the bridge in the condition that the pillar wheel is set on.
- When disassembling and assembling the bridge, pay attention not to deform the clutch spring, chronograph finger and the fourth wheel and pinion.

Since the three parts shown in the following diagram are set on the cover of the barrel, these parts are not necessary to remove when replacing or cleaning the mainspring.

(Friction spring for intermediate hour recording wheel)  
(Intermediate hour recording wheel)  
(Intermediate hour recording wheel ring)

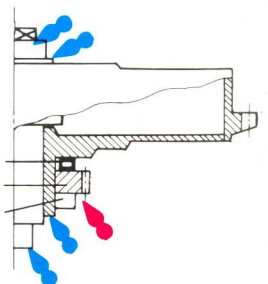

Fig. 7

# 6138A Hour Chronograph Mechanism

**62** Calendar plate screws (3 pcs)

After tightening the *calendar plate* screws, check whether or not each lever operates smoothly by pressing the portion marked with \*① on the *hour fly-back lever*. Causes of malfunctions are considered to come from defective assembly and/or lever warp when replaced with a new one.

**63** Calendar plate

Pay attention not to break or bend the *hour hand axle* when attaching or detaching the *calendar plate*. When assembling the *calendar plate*, check on pivoting of the *hour hand axle*, and the interlocking condition between the *hour wheel* and the *intermediate date wheel*. If the *hour fly-back lever* protrudes to the outer circumferential side, the *calendar plate* cannot be assembled. Thus, assemble the *calendar plate* while pushing the *hour fly-back lever* toward the center.

**67** Spring for hour recording wheel stop lever

1. The *hour recording stop lever axle* is designed as shown in Fig. 8; when detaching the *spring*, remove it by slightly bending it.

2. The *hour recording stop lever spring axle* is an eccentric pin. Do not turn it as it is not screw. If it is turned inadvertently, always correct it so that the groove of the *eccentric pin* (arrow mark) faces the center of the *hour recording wheel*. Correct it in a direction that spring force becomes strong as illustrated left in Fig. 9.

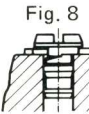

**68** Intermediate hour recording wheel stop lever

**69** Hour recording wheel stop lever

**70** Hour recording wheel

Pay attention not to scratch the teeth of the *hour recording wheel* when handling it.

**71** Intermediate date wheel

Assemble the *intermediate date wheel* with the pinion positioned upward.

**72** Hour wheel

The *hour recording stop lever spring axle* is an eccentric pin; do not turn it. If it is turned inadvertently, adjust it by referring to Fig. 9.

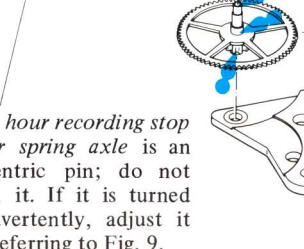
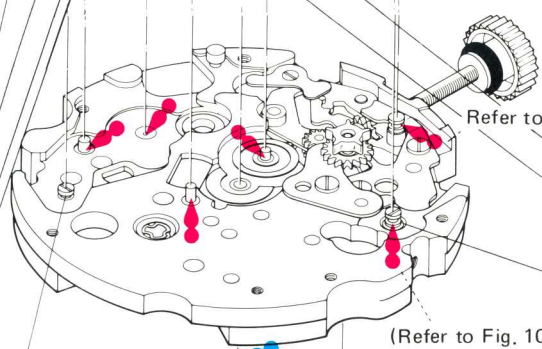
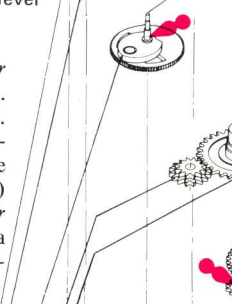
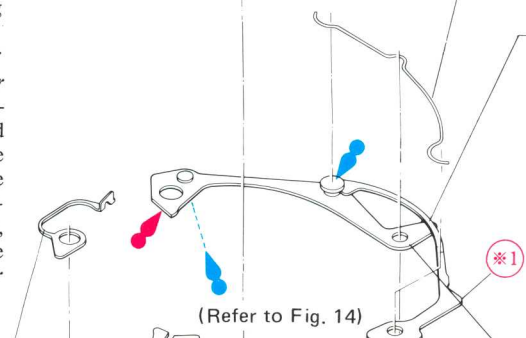
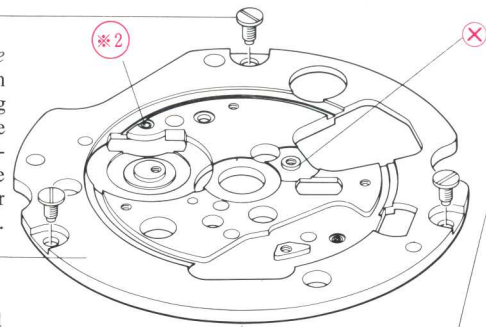

Hour hammer spring **64**

Refer to Fig. 15 in 6138A-7 for the set position of the *hour hammer spring*. A cross section diagram of the portion around the *eccentric pin* of the plate is shown in the following diagram. Correctly set the *eccentric pin* in the grooved portion.

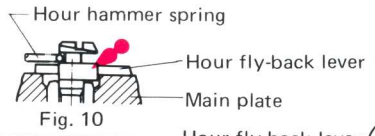

Hour fly-back lever **65**

1. Refer to Fig. 15 in 6138A-7 for the set position of the *hour fly-back lever*. The cross section diagram is shown in Fig. 10. Correctly set it to the eccentric portion.
2. Do not turn the *eccentric pin* of the *hour fly-back lever*. If it is turned inadvertently, correct it as shown in Fig. 11.

Fig. 11 Correct the *eccentric pin* so that the larger surface of it faces the *second button*.



Hour hammer **66**

Refer to Fig. 17 in 6138A-8 and the following diagram for the set position of the *hour hammer*.

1. Set position of the *hour hammer axle*

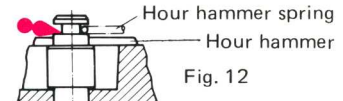

2. Interlocking with the *intermediate hour recording wheel stop lever*

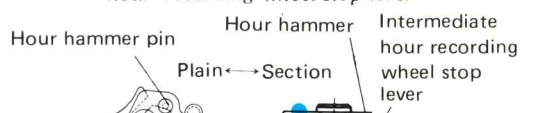

Hour hammer pin  
Plain → Section  
Fig. 13

Hour hammer  
Intermediate hour recording wheel stop lever  
Fig. 14

Minute wheel **73**

Cannon pinion **74**

The *hour fly-back lever axle* is an eccentric pin; do not turn it. If it is turned inadvertently, adjust it by referring to Fig. 10.

Center wheel **77**

Center wheel bridge **76**

Center wheel bridge screw **75**

# 6138A Operation of Chronograph Mechanism

Stopping of chronograph minute and second hands

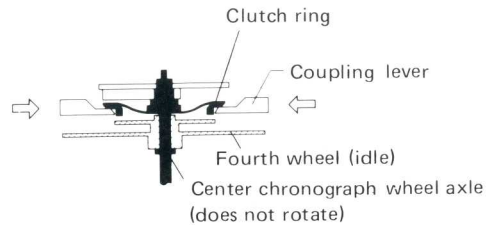

## Stopping

The *minute and second recording wheels* are stopped when the *clutch ring* is raised through action of the *coupling levers*. The *hour recording wheel* comes to a halt by a slip of the *hour recording friction spring* of the barrel. The slip comes from the fact that the *hour recording wheel stop lever* brakes the *hour recording wheel* by the *spring for hour recording wheel stop lever*.

Stopping of chronograph hour hand

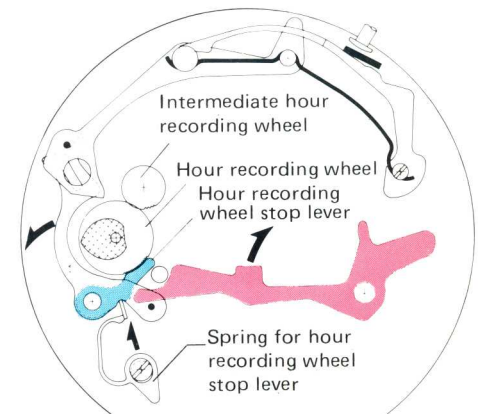
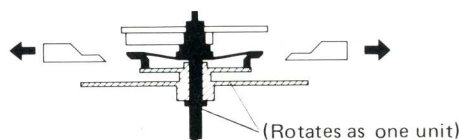

Fig. 15

Starting of chronograph minute and second hands



## Starting

The *minute and second recording wheels* are started when the *coupling levers* are separated from the *clutch ring*. Simultaneously, the *second coupling lever* pushes the *intermediate hour recording wheel stop lever pin*, revolving the *intermediate hour recording wheel stop lever* in the → direction. And then, the force of the *spring for hour recording wheel stop lever* is not transmitted to the *hour recording wheel stop lever* to release the brake of the *hour recording wheel* and let it start.

Starting of chronograph hour hand

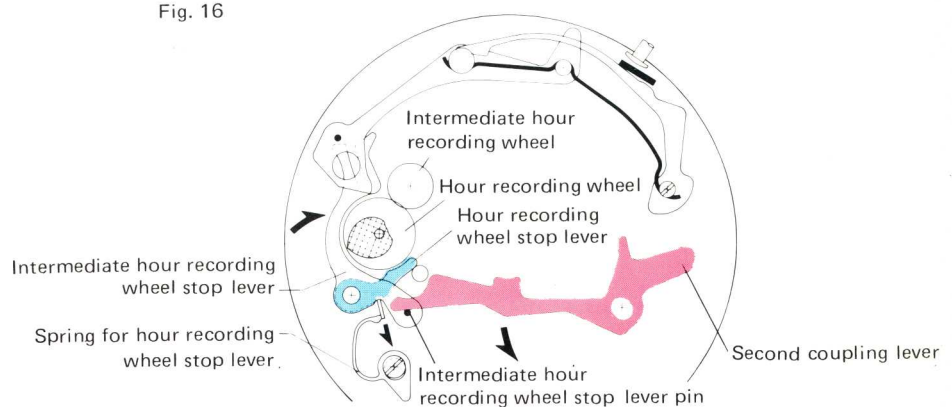

Fig. 16

# 6138A Operation of Chronograph Mechanism

## Resetting

### 1. Resetting of the chronograph minute hand and second hand

When pressing the *second button*, the force is transmitted to *fly-back lever* → *intermediate fly-back lever* → *hammer*, and the *hammer* strikes the *minute heart* and the *second heart* to reset the hands to "0" position.

### 2. Resetting of the chronograph hour hand

Simultaneously with the above, the *fly-back lever* presses the *hour fly-back lever* and the force is transmitted to the *hour hammer* to reset the *chronograph hour hand* to "0" position. At this moment, the *intermediate hour recording wheel stop lever* revolves in the → direction by action of the *hour hammer pin*, and the *hour recording wheel* is released. When the *second button* is released, the *chronograph hour hand* returns to a stopped condition.

Resetting of chronograph minute hand and second hand

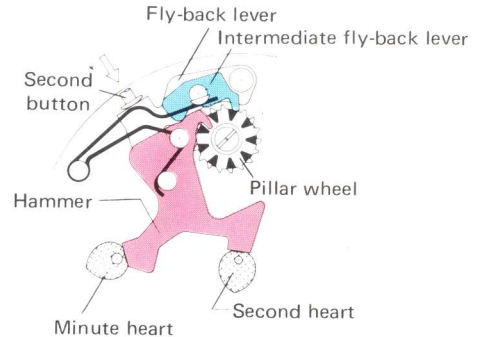
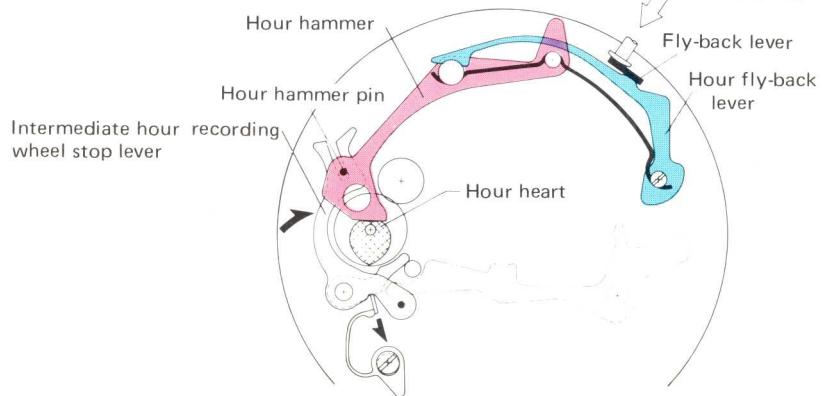

Fig. 17

Resetting of chronograph hour hand



## Fly-back safety mechanism

This mechanism protects the movement from the shock generated by the *second button*. End portions of the *hammer* and the *intermediate fly-back lever* are located outside the column during starting condition. When the *second button* is depressed, the end portion of the *intermediate fly-back lever* slips among the columns of the *pillar wheel* (as shown in Fig. 18), and the force is not transmitted beyond the *hammer*. On the other hand, the *hour hammer* does not move because the pin located on its tip strikes the *intermediate hour recording wheel stop lever*. At this moment, momentum of the *second button* is absorbed by a springing characteristic of the *hour fly-back lever*. Safety action is exhibited by integration of the above-mentioned operations.

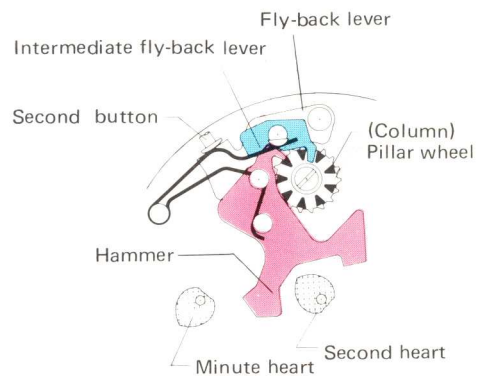
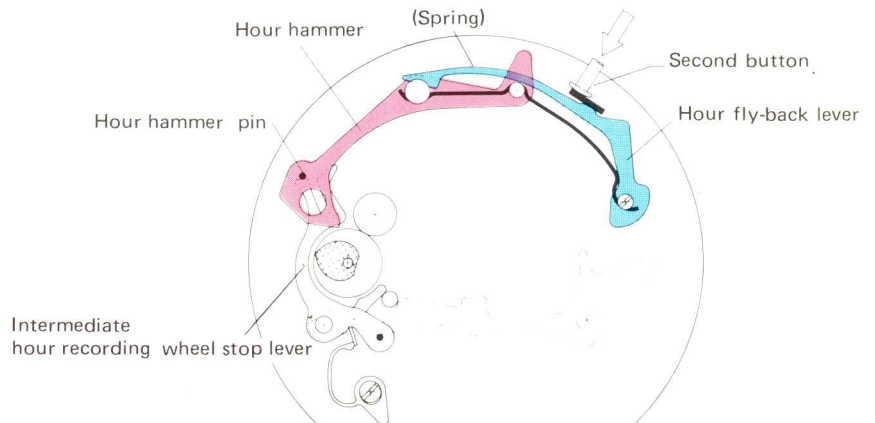
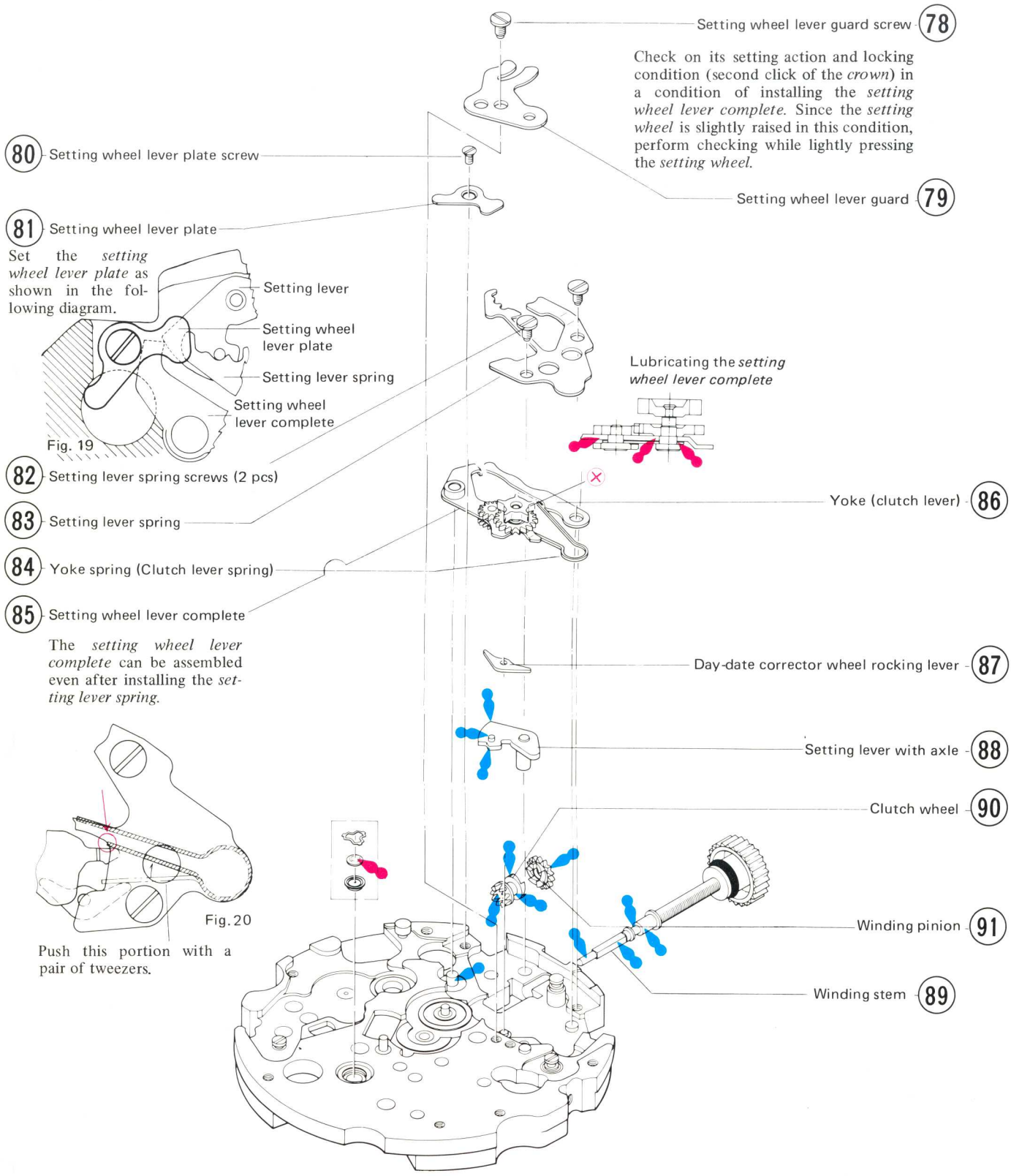

Fig. 18



# 6138A Setting Mechanism



## 6138A Setting Mechanism

### Ordinary position of crown (main-spring winding)

The *crown wheel* and the *second intermediate ratchet wheel* are caulked on the *barrel* and *train wheel bridge*. The *intermediate ratchet wheel* is supported by a pin mounted on the plate.

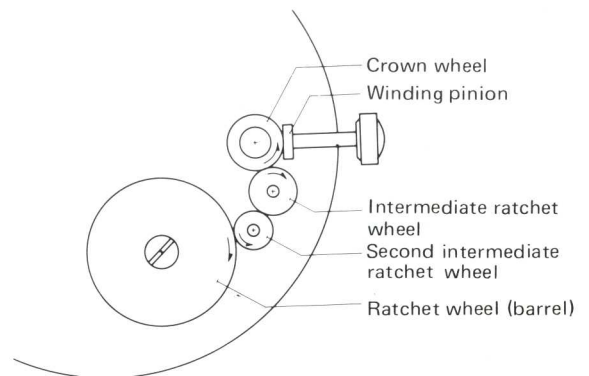

Fig. 21

### Second position of crown (day and date correction)

#### 1. Clockwise – Date correction

When turning the *crown* to the right (clockwise), the *correcting gear* moves to the *date dial* side and interlocks with it, thus date is corrected. Force transmission is through *crown* → *clutch wheel* → *setting wheel* → *correcting gear* → *date dial*.

#### 2. Counterclockwise – Day correction

When turning the *crown* to the left (counterclockwise), the *correcting gear* moves to the *day star with dial disk* side and interlocks with the *intermediate wheel for day correction*, and day is corrected. Force is transmitted through *crown* → *clutch wheel* → *setting wheel* → *correcting gear* → *intermediate wheel for day correction* → *day star with dial disk*.

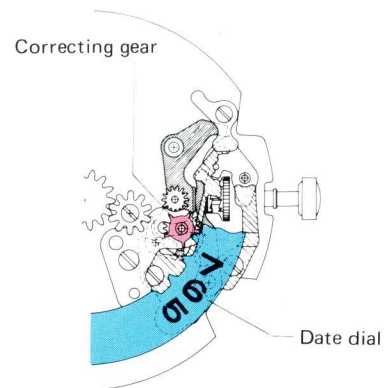

Fig. 22

### Third position of crown (setting time)

The *setting wheel lever complete* moves to the *minute wheel* side by action of the *setting lever with axle*, and the *intermediate setting wheel* interlocks with the *minute wheel*, hand is set correctly. Simultaneously, motion of the *setting wheel lever complete* is transmitted to the *day-date correction wheel rocking lever*, and the *correcting gear* attains a position where it interlocks neither the *date dial* nor *intermediate wheel for day correction* by action of the *setting wheel lever complete* and the *day-date correction wheel rocking lever*.

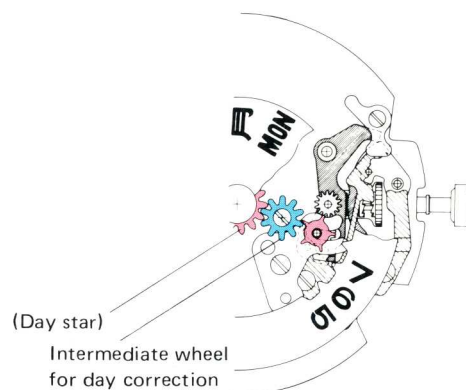

Fig. 23

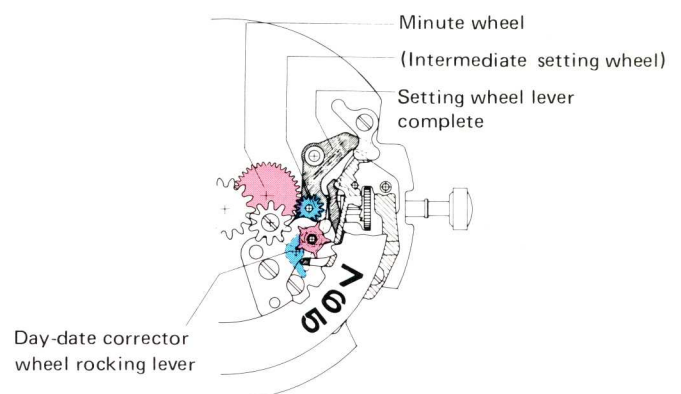

Fig. 24