

SEIKO

ELECTRONIC WATCH

EL-370

1. PRINCIPLE OF OPERATION

- 1-1 Specification and Features.....1-3703B-1**
- 1-2 Principle of Operation1-3703B-2**
- 1-3 Characteristic of Power Cell1-3703B-4**

3703B

1) Specifications

Casing diameter:	29.0mm
Height:	6.6mm
Vibrations per hour:	21,600
Driving mechanism:	Balance driven system
Attached mechanisms:	Power supply switch Second-setting device Calendar (push-type Date Corrector and reciprocating Day Corrector)

Applicable power cell (EVEREADY EPX-77):

Capacity:	165m AH
Voltage:	1.5V
Size:	11.6 ϕ mm x 5.6mm

2) Features

The non-contact-points type electronic watch EL-370, whose balance complete with stud drives the movement, offers high utility. It withstands changes in outside conditions such as magnetism and temperature, and is designed for easy handling at retail stores. Its features are as follows:

- 1) Power cell durability exceeds one year.
- 2) Anti-magnetism quality is enhanced by an application of nonmagnetic materials for the balance and special metals for the case back.
- 3) The power cell to be readily replaced by opening the power cell lid.
- 4) For easy servicing, unit-servicing-system is employed such as Electronic circuit unit and so on.
- 5) Equipped with a power supply switch (which also functions as the second-setting device), a crown-push type date corrector, and a reciprocating type day corrector.



Movement

3703B Principle of Operation

1) Outline of operation

Construction of the driving mechanism embodying the balance complete with stud is shown in Fig. 1.1. Operation of the balance complete causes current to flow through the primary coil, and the current actively drives – through the induction coil – the balance complete. This sequence keeps driving the balance. The oscillations of the balance drives the Jewelled pallet and power is conveyed from the escape wheel to the train wheel to control the hand-setting mechanism.

Operating chart

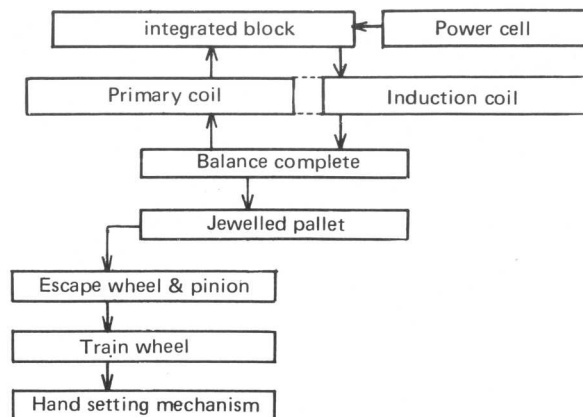

Fig. 1-1

2) Operation of balance and integrated block

- 1) When the crown is depressed from the hand-setting position (the power cell switch is OFF) into the normal position, the second setting is released and the hand-setting lever let the balance start by kicking it off in the arrow direction (see Fig. 12). At the same time, the power cell switch is turned ON and the integrated block is ready to function.
- 2) When the balance is started, the magnetic field of the upper and lower magnets of the balance, passes through the fixed coil and generates a weak current in the primary coil (L₂).
- 3) The weak current generated in the (L₂) flows into the base (B) of the transistor (Tr) and on into the emitter (E) (→ ① in Fig. 1.2). When it flows to (E) from (B), collector (C) and (E) open; as a result, the main current flows through the induction coil (L₁) (→ ② in Fig. 1.2).
- 4) When the main current flows through the (L₁) magnetism is generated in it.
- 5) The balance is rotated due to repelling between the permanent magnet attached to the balance and the magnetism produced in the coil.
- 6) In this way, in accordance with the electricity which is generated in (L₂) at the moment when the magnets attached to the balance pass the coil, main current flows into (L₁) and swings the balance and keep it oscillating.

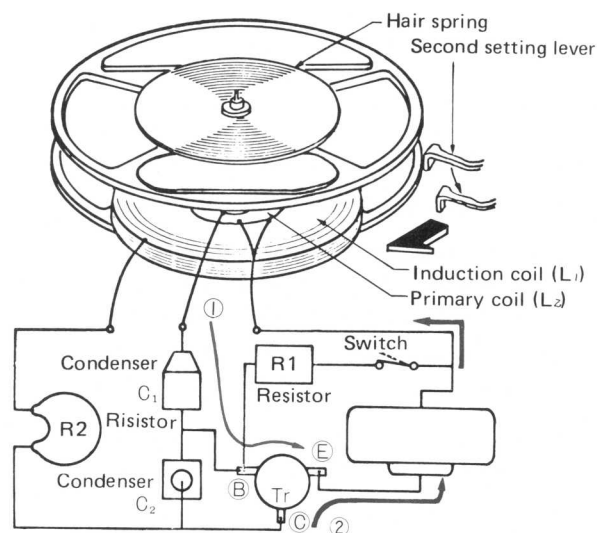

Fig. 1-2

The mechanism of the balance and the integrated block is as shown in Fig. 1.3.

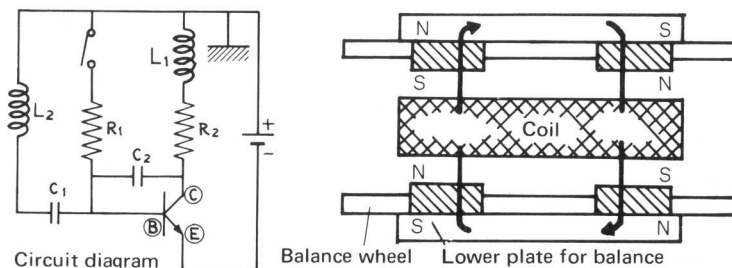

Fig. 1-3

3703B Principle of Operation

3) Escapement

In contrast to the escapement of conventional mechanical watches, the EL-370 employs a reversed type which conveys driving energy from the balance to the jewelled pallet, whose pallet jewels rotate the escape wheel to convey the energy to the train wheel. That is, the direction of transmitting force is reversed. To ensure its drawing force at a stop, the jewelled pallet is equipped with a permanent magnet.

- 1) This permanent magnet and the banking pin magnetically draw each other so that the jewelled pallet is drawn to the side of the pallet cock. The roller jewel enters the fork slot to operate the jewelled pallet.

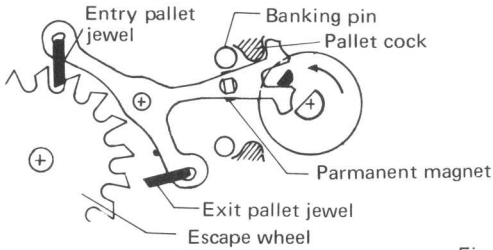

Fig. 1-4

- 3) The jeweled pallet is kept in a halted condition by the drawing force of the permanent magnet.

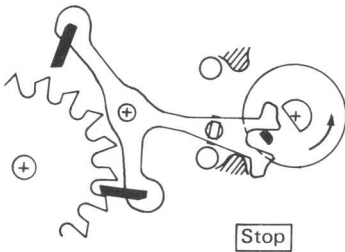

Fig. 1-6

- 2) The impulse surface of the exit pallet jewel pushes that of the escape wheel which is moved in the arrowed direction.

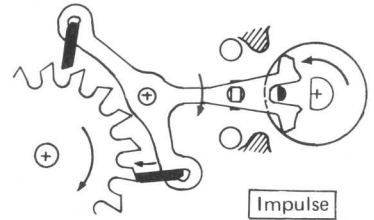

Fig. 1-5

- 4) The roller jewel returns to enter the fork slot and moves the jewelled pallet in → direction. At the same time, the impulse surface of the entry pallet jewel pushes that of the escape wheel and pinion, which is moved forward.

The sequence of the above operations is repeated.

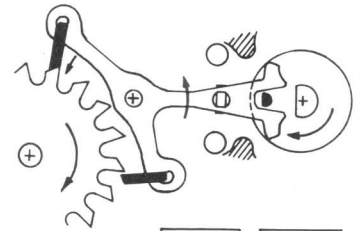

Fig. 1-7

Retaining pawl mechanism

The escape wheel and pinion is equipped with the click wheel. When a reverse torque due to operation of the date driving wheel, hands setting, and so on, is applied to the train wheel, reversal of the escape wheel is prevented by the engagement of the click wheel and the retaining pawl.

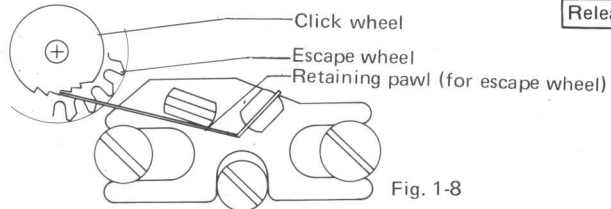

Fig. 1-8

4) Train wheel

Arrangement of the train wheels is shown in Fig. 1-9. Driving torque is transmitted in the direction opposite to that of a mechanical watch.

The torque of the escape wheel and pinion is conveyed as follows: from the sweep second wheel and pinion to the second hand, through the sweep second wheel and pinion and the third wheel and pinion to the minute hand of the cannon pinion, from the cannon pinion, through the minute wheel to the hour hand of the hour wheel.

The sweep second wheel is equipped with a friction spring for sweep second pinion, which brakes the sweep second wheel and prevents the second hand from fluctuating.

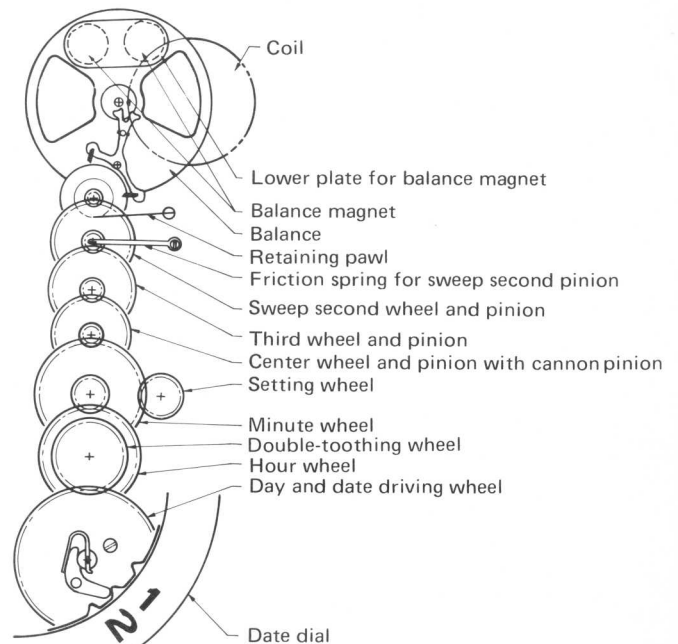
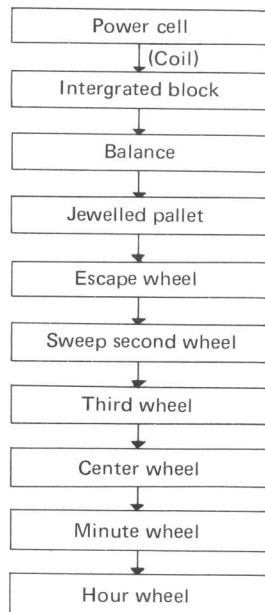

Fig. 1-9

3703B Principle of Operation

5) Power supply switch and second setting device

When the crown is pulled out, the clutch lever moves in the arrow direction shown in Fig. 1.10 and go away from the contactor pin, disconnecting the current flow through the integrated block.

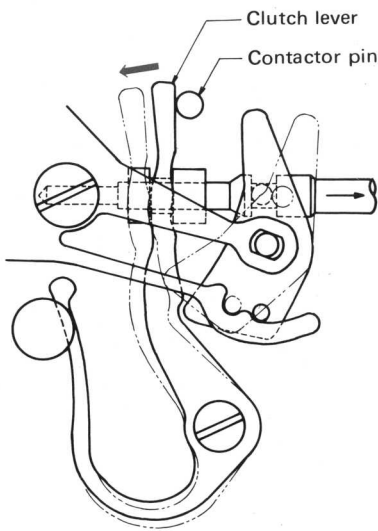

Fig. 1-10

- The second setting lever, fitted in the slot of the clutch wheel, stops the balance complete when the crown is pulled out. It also functions as the starter by kicking off the balance wheel when it is released.

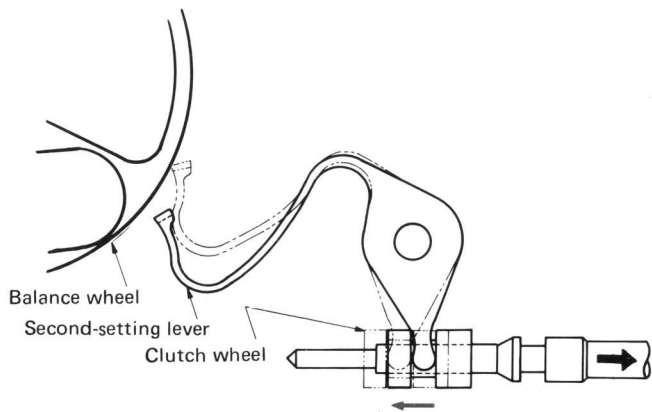

Fig. 1-11

6) Calendar correcting mechanism

When the crown is depressed, the hand-setting stem, setting lever with axle, date corrector, and date corrector finger are brought into interlocking to correct the date.

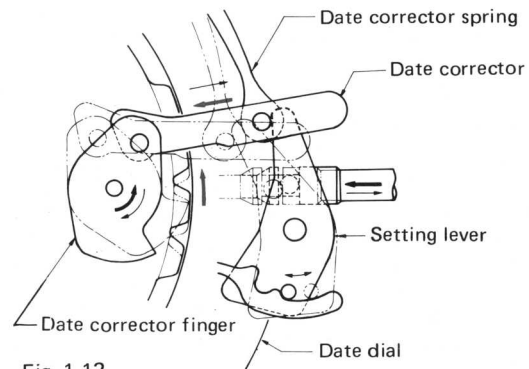

Fig. 1-12

Characteristics of Power Cell

The power source of the EL-370 is a silver-oxide mini-battery (its positive electrode of silver oxide, its negative electrode of zinc, and its electrolyte a concentrated alkaline solution.) Its features are as follows:

1. A constant operating voltage, whose deterioration during discharge is quite limited.
2. A large electric capacity.
3. It hardly deteriorate against changes in the outside temperature, always a reliable operating condition.
4. The power cell is suitable for discharging a micro current for long periods, and there is no possibility of electrolyte leakage.

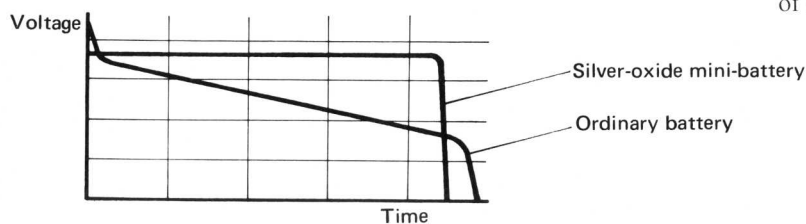

Fig. 1-13

SEIKO

ELECTRONIC WATCH

EL-370

2. REPAIR JIGS AND TOOLS

2-1 Repair jigs and Tools for EL-370.....2-3703B-1

3703B Repair Jigs and Tools

1) Tester

The tester is used for measuring current, power cell voltage, and circuit resistance; it must meet the following requirements:

- ① It must be applicable to the following measuring ranges:

Current:	5 to 15 μ A
Voltage:	1.4 to 1.6V
Resistance:	0.5 to 15 K Ω
- ② Internal resistance

For measuring voltage:	over 20 K Ω
For measuring current:	over 2 K Ω

2) Condenser kit

For measuring current consumption, be sure to use a condenser.

Connect lead wire and clips as shown in the figure below to a condenser of 200 to 500 μ F (withstandability is over 3V).



4) Power cell holding spring and set screw

When putting the watch in motion with the case back open, use the holding spring for the power cell to pass current and to hold the power cell in position.



Suggestion:

When making the holding spring, use a metal plate of good conductivity referring to the procedure as shown in Fig. 2.1.

5) Others

- 1) Nonmagnetic tweezers: Used to handle the parts with magnets such as the jewelled pallet fork and staff, balance complete with stud.
- 2) Nonmetallic tweezers: Used to handle the power cell. (The wear finger coat when handling the power cell or tweezers of bamboo or plastic can be used.)



3) Movement holder

Use a special movement holder for EL-370.



Cut the metal plate to suitable size.

Bend the plate and drill a hole in it.

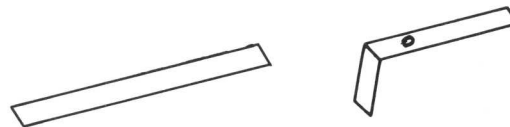

Fig. 2-1

SEIKO

ELECTRONIC WATCH

EL-370

3. DISASSEMBLING AND REASSEMBLING THE WATCH AND REPLACING THE POWER CELL

3-1 Replacing the Power Cell	3-3703B-1
3-2 Calendar Mechanism	3-3703B-2
3-3 Integrated Block	3-3703B-3
3-4 Controlling Mechanism and Escapement	3-3703B-4
3-5 Train Wheel	3-3703B-5
3-6 Setting Mechanism	3-3703B-6

Disassembling and Reassembling

- 1) Disassemble the watch according to the procedures shown in figures (1) to (53)
- 2) Reassemble the watch according to the procedures (53) to (1)
- 3) For disassembling and reassembling procedures marked ▶ refer to the manual of inspecting procedures and repairs.

Lubricating the Watch

The following symbols appearing in the disassembling and reassembling diagrams indicate the types of oil, its quantities to be applied, and lubricating points:

- Types of oil**
- ▶ Moebius Synt-A-Lube
 - ▶ SEIKO Watch Oil S-4

- Oil quantity**
- ▶ Sufficient quantity
 - ▶ Normal quantity
 - ▶ Extremely small quantity

3703B Replacing the Power Cell

3-1 Replacing the Power Cell

The power cell can be readily replaced simply by removing the power cell lid.

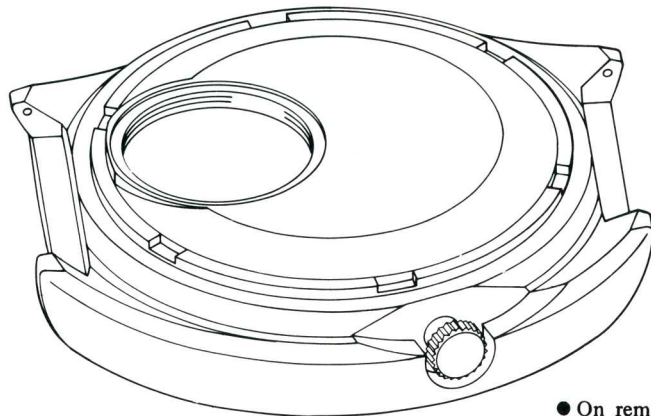
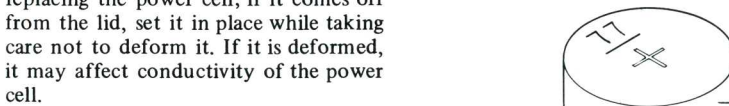
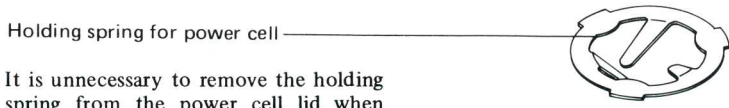
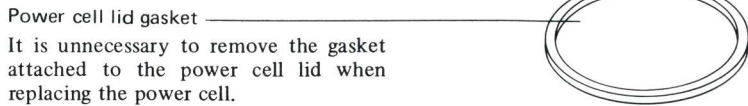

● On removing the power cell lid, the watch ceases to run.

Note:

1. Store packed power cells in a storage area where the temperature is comparatively low and humidity is relatively low.
2. Be sure to discard used power cells (if they are left intact, they may not be distinguishable from brand-new ones).
3. Wipe it thoroughly with a dry cloth before putting it to use. If an (+) pole surface has something printed, wipe off the print with thinner or benzene.

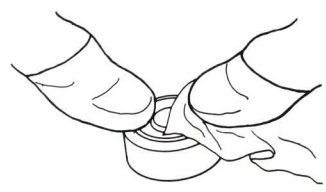

If the power cell is overheated by direct fire or direct soldering, it may explode. Be sure to avoid overheating it.

3703B Calendar Mechanism

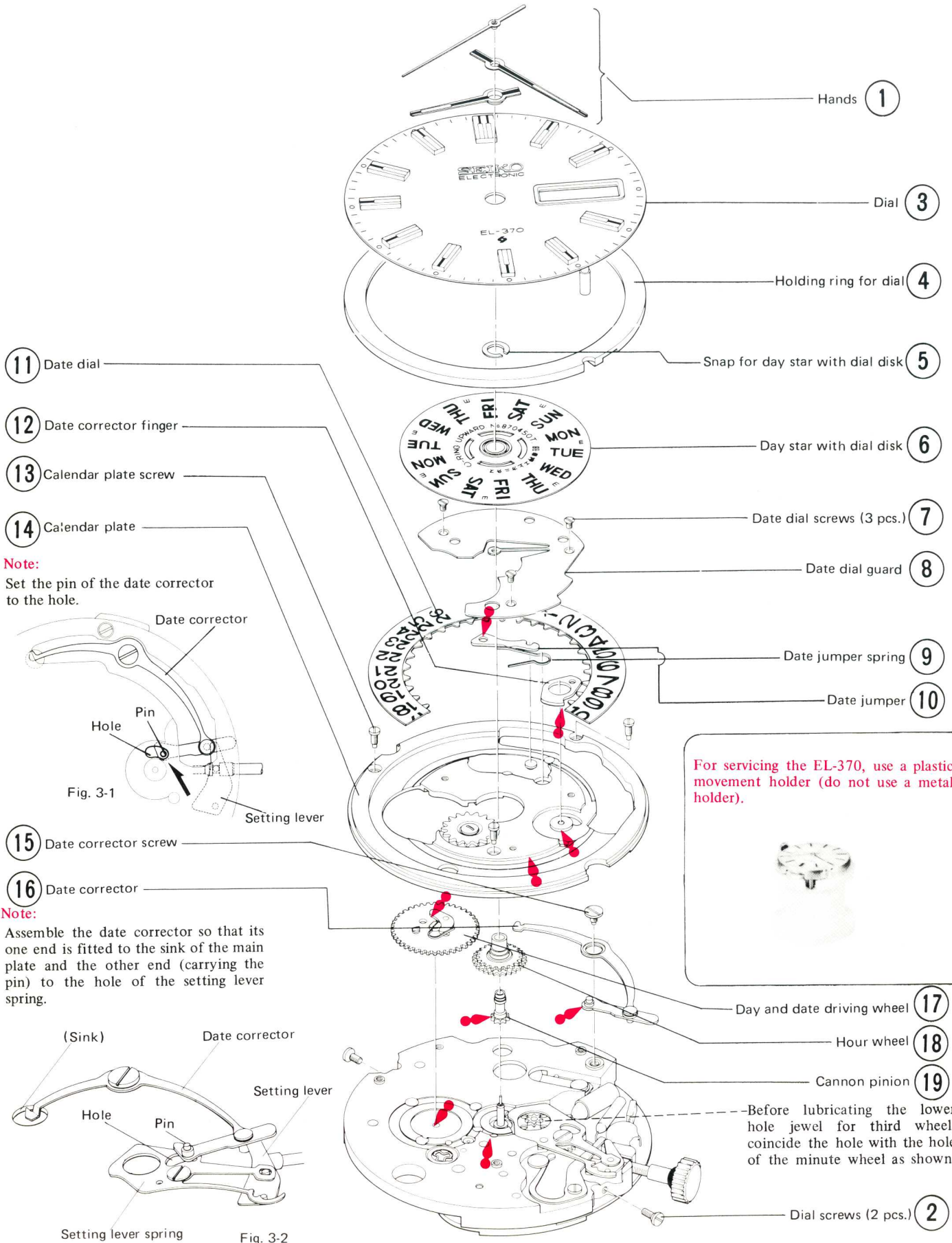

3703B Integrated Block

20 Power cell

- Handle the power cell carefully to avoid short-circuiting.
- Use a EPX-77 power cell.
- Before setting a power cell, check it for voltage.
- ▶ For the checking of the voltage, refer to 4.3703B-2.

Note:

- 1) After setting the power cell, hold it with a temporary power cell holding spring (necessary for ascertaining if the watch works) as shown in Fig. 3-3.

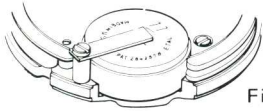

Fig. 3-3

- 2) On adjusting the hand-setting stem to its normal position, the watch will begin to run. By so doing, the following checks are required.

- ▶ Check on current consumption according to 4.3703B-2 and check on the amplitude. If it refuses to function, repair it according to the Guide to Inspection and Repair.
- 3) If the stroke of the timegrapher is weak, adjust its volume.

22 Coil block screws (2 pcs)

When tightening or loosening the coil block screws, be careful not to break the coil.

[Coil block]

[Circuit block]

Do not disassemble the coil block and circuit block except when inspecting and repairing them,

23 Circuit block screws (2 pcs)

(The circuit block screw in the diagram on the right is for grounding the terminal.)

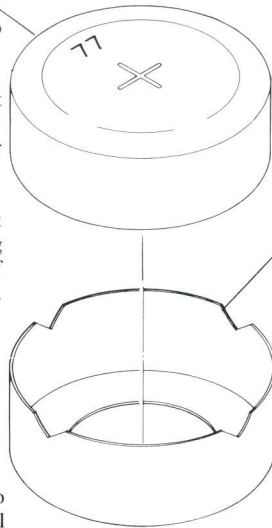

21 Insulating cap for power cell

Since the insulating cap for power cell is used to prevent a short circuit, be sure to mount it on the assembly.

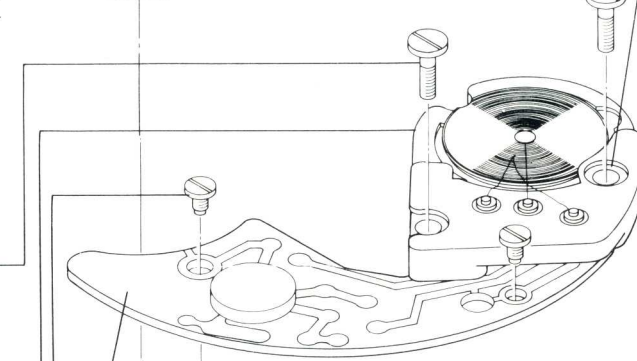

24 Integrated block

The coil block combined with circuit block is referred to as an "Integrated block."

- 1) Assemble the integrated block by turning the balance wheel through an angle of about 90 degrees from its rest position (Fig. 3.4).

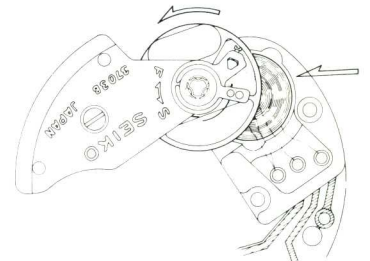
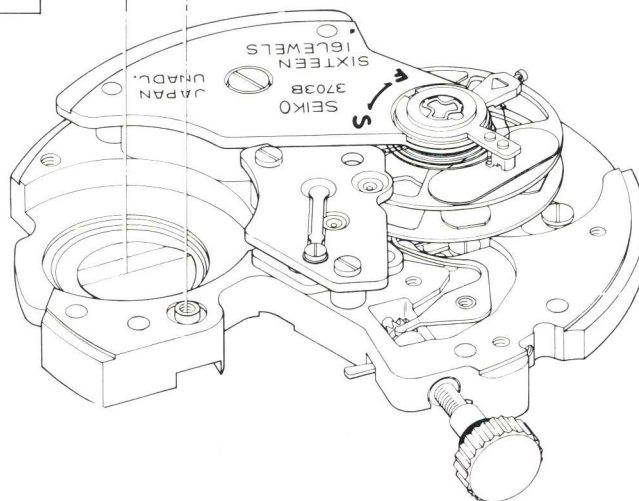

Fig. 3-4



- 2) When replacing the circuit and coil blocks, inspect and replace each block and tighten the terminal screw of integrated block.

- ▶ For replacing the circuit and coil blocks, refer to 4.3703B-4.
- 3) After assembling the integrated block, check the following:
 - ▶ For checking of clearance between the coil and the balance complete with stud, refer to 4.3703B-5.
 - ▶ For checking and adjusting the power supply switch, refer to 4.3703B-3.

3703B Escapement and Governor Mechanism

Warning

Since the EL-370 employs magnets for its balance complete with stud and the jewelled pallet fork and staff, never demagnetize its complete movement or any part of it.

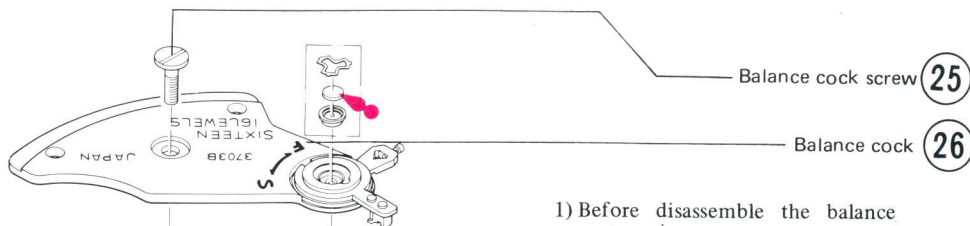

28 Balance cock washer

29 Second-setting lever

Note:

- 1) If the spring portion is deformed, the lever's second setting performance will be affected.
- 2) When assembling the integrated block, confirm that the second-setting lever is in correct position.

30 Retaining pawl screws (2 pcs)

Note:

- Tighten the retaining pawl screws so that they are located in the center of the retaining pawl (for escape wheel) as shown.

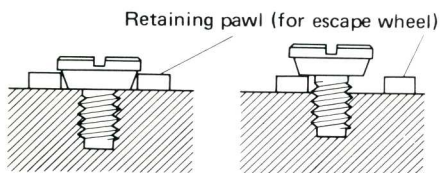

Fig. 3-5

32 Pallet cock screws (2 pcs)

33 Pallet cock

After assembling the pallet cock, be certain to check on the drawing force of the permanent magnet.

- For this checking procedure, refer to 4.3703B-5.

34 jewelled pallet fork & staff

- 1) Since the jewelled pallet is equipped with magnets, be sure to handle it with non-magnetic tweezers.
- 2) Remove the chips and dust from permanent magnet.

- 1) Before disassemble the balance cock, disassemble the circuit block.
- 2) Handle the balance complete with stud very carefully.

Balance complete with stud 27

Note:

Since the balance complete with stud has two wheels (the upper wheel and the lower wheel both having two magnets each), be careful of the follows:

- 1) Handle it with non-magnetic tweezers.
- 2) Handle only one of the upper or lower balance wheels with tweezers. If the both wheels are held together, the clearance between them will be changed and they may sometimes scrape against the coil.
- 3) Remove chips and dust from the magnets. It is convenient to use the "Scotch tape."

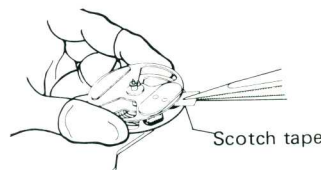

- 4) To prevent the balance wheels from rubbing against the coil, check it for shakes.

► For adjusting the clearance, refer to 4.3703B-5.

Retaining pawl 31

Note:

- 1) Do not turn the spring pin driven into the retaining pawl except when adjusting it.
- 2) By operating the jewelled pallet, confirm if the retaining pawl properly engages with the click wheel of the escape wheel (if this engagement is improper, it will cause the watch stopping).

► For inspecting the retaining pawl, refer to 4.3703B-6.

- 3) After inspection of (2), above, check the contacting condition of the jewelled pallet fork and staff with the escape wheel by referring to Fig. 3.6, below.

Amount of contact at initial stage of impulse

Amount of contact at the stopping condition

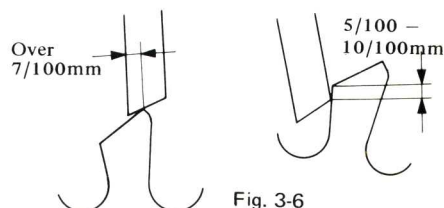
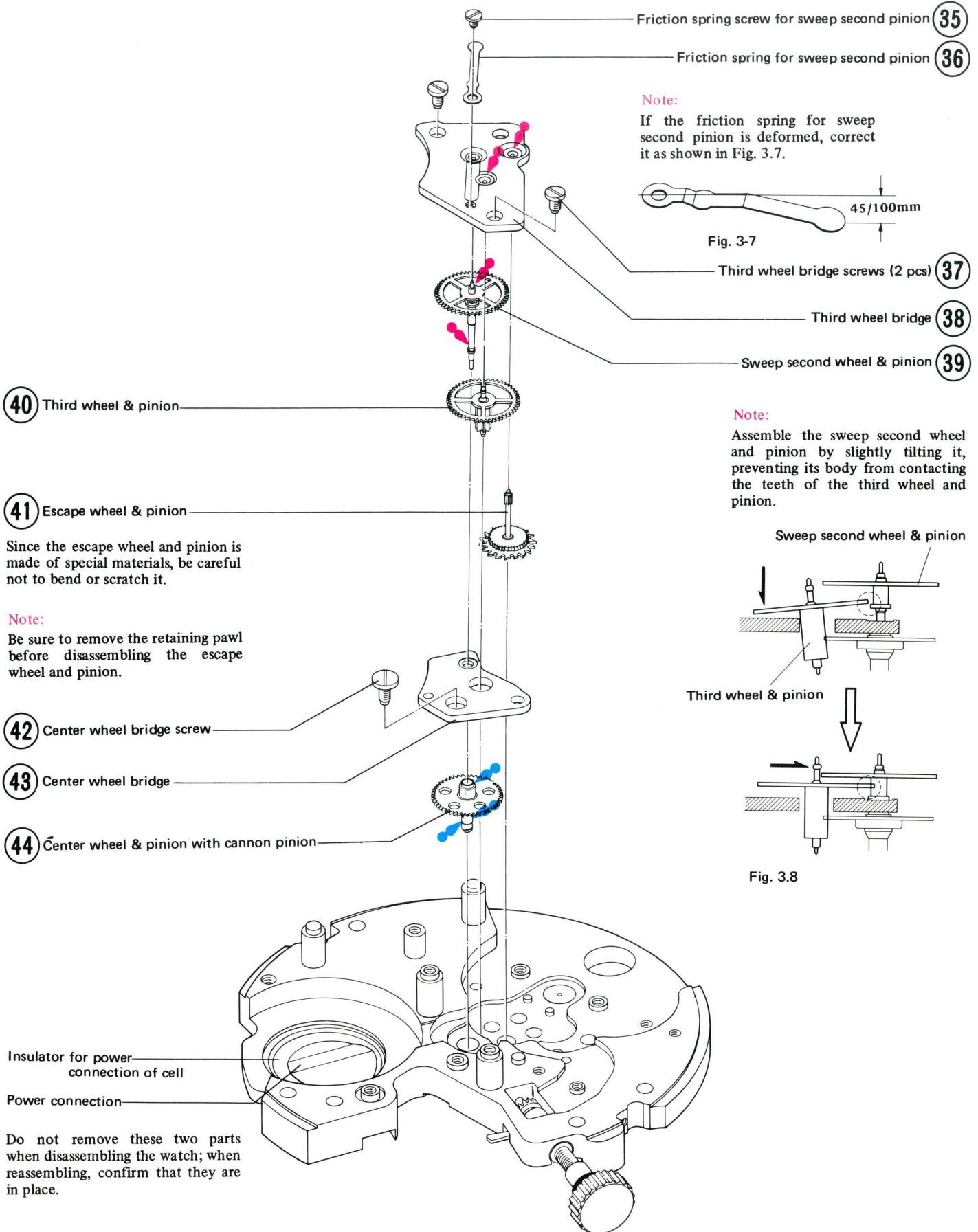

Fig. 3-6

When checking the amount of contact at the initial stage of impulse, turn the escape wheel in reverse direction by the amount of play between the retaining pawl and click wheel.

3703B Train Wheel



3703B Setting Mechanism

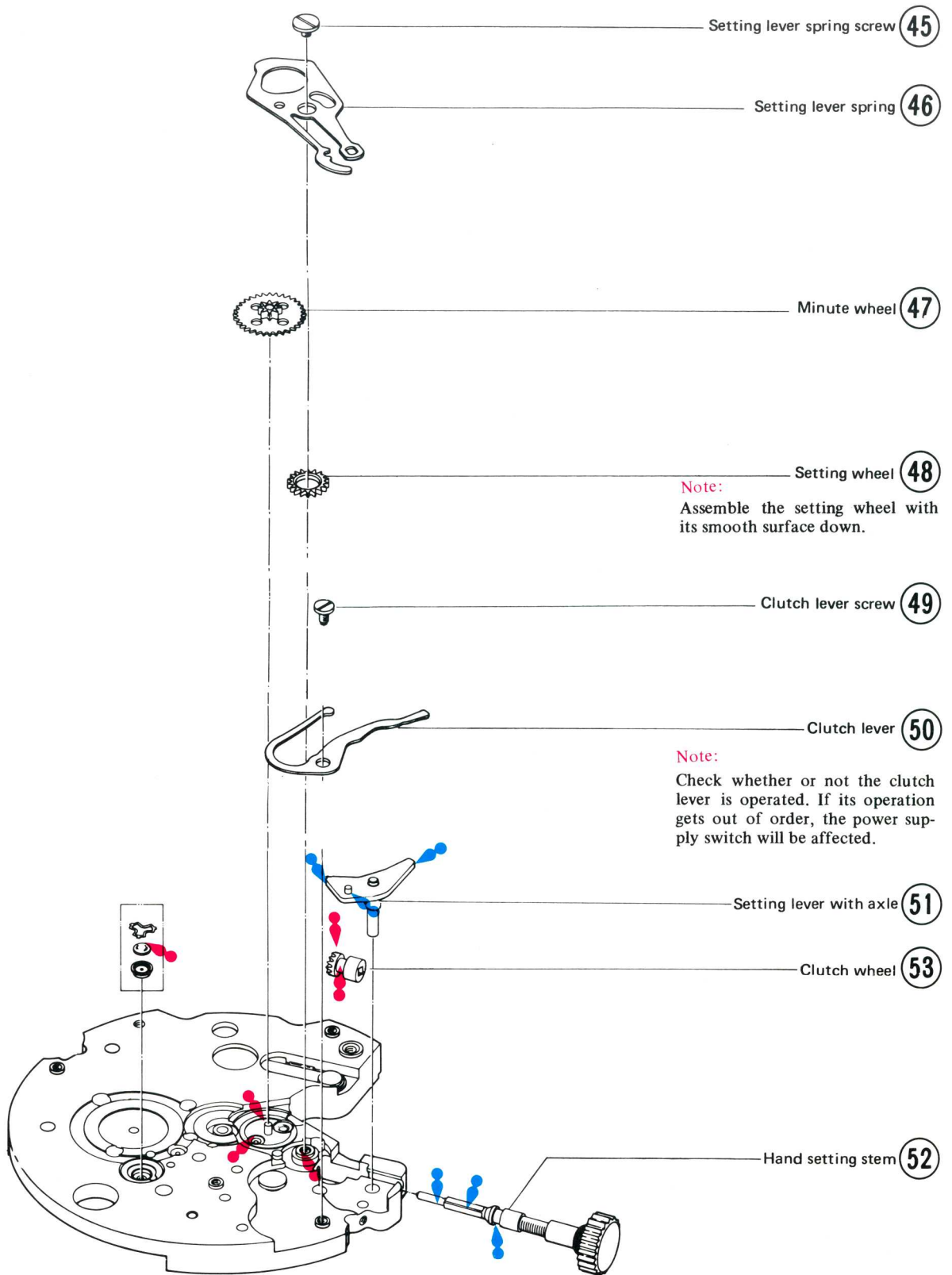

SEIKO

ELECTRONIC WATCH

EL-370

4. INSPECTION AND REPAIR METHODS

4-1 Guide to Repairs.....	4-3703B-1
A. Inspecting the Power Cell Voltage	4-3703B-2
B. Inspecting the Current Consumption.....	4-3703B-2
C. Inspecting and Repairing Continuity of the Holding Spring for Power Cell.....	4-3703B-3
D. Inspecting and Repairing Continuity of the Switch	4-3703B-3
E. Inspecting and Repairing Continuity of the Power Connection for Cell.....	4-3703B-3
F. Inspecting and Repairing Continuity of the Integrated Block	4-3703B-4
G. Inspecting and Adjusting Clearance Between the Balance Complete with Stud and the Coil	4-3703B-5
H. Inspecting and Adjusting the Drawing Force of Jewelled Pallet Fork and Staff	4-3703B-5
I. Inspecting and Adjusting the Retaining Pawl	4-3703B-6

3703B Guide to Repairs

The EL-370 depends on a silver-oxide mini-battery for its power source. Many of the repairs required for battery watches originate from the life of this power cell; when repair work is necessary, initially check on the power cell and then follow the inspecting and repairing procedures given below.

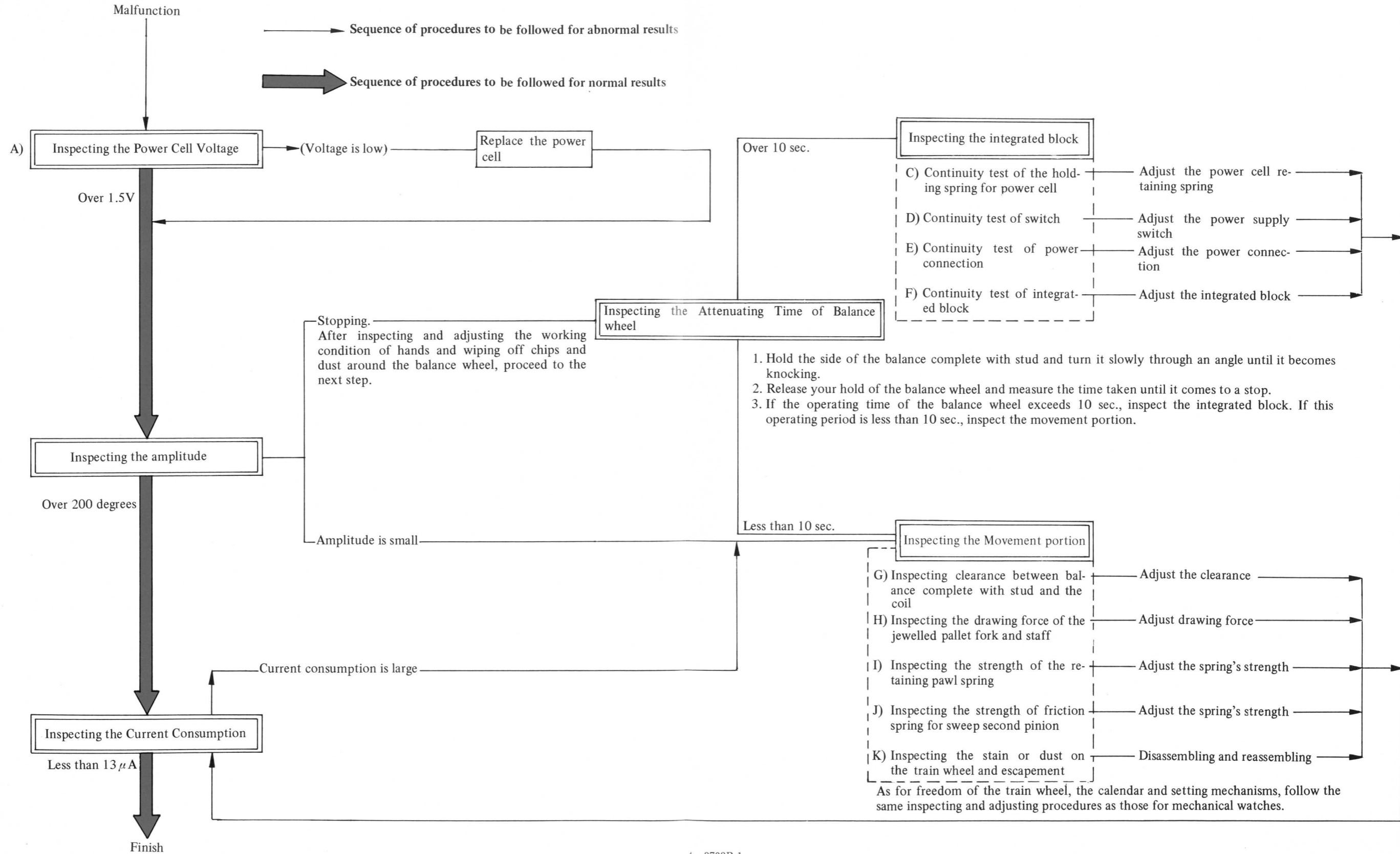

3703B Inspecting the Power Cell Voltage, Inspecting the Current Consumption

A. Inspecting the Power Cell Voltage

Confirm if the power cell voltage is normal.

Procedures

- 1) Set the tester for measuring a voltage of 1.4 to 1.6V.
- 2) Apply the lead-plug of the tester as under (Fig. 4.1);
(+) lead-plug — (+) surface of the cell.
(-) lead-plug — (-) surface of the cell.

Results

Over 1.5 V : in order
Under 1.5 V : replace the cell according to 3.3703B-1

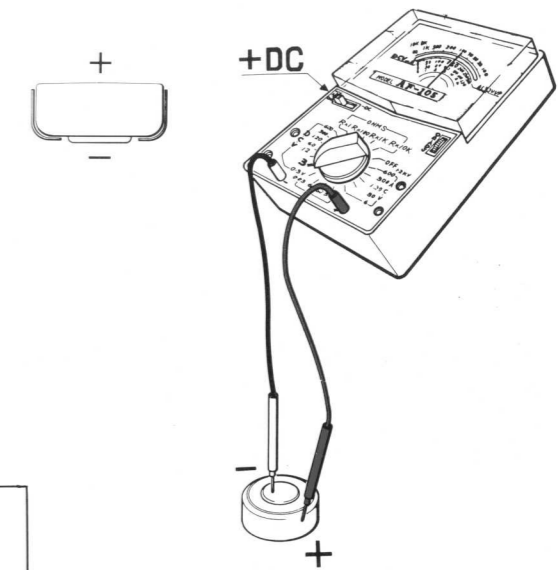

Fig. 4-1

B. Inspecting the Current Consumption

Check the current consumption of the watch.

Procedures

- 1) Set the tester for measuring a current whose strength is 5 to 15 μ A (use a condenser).
- 2) Apply the lead-plug of the tester as under (fig. 4.2);
(+) lead-plug — (+) surface of the cell.
(-) lead-plug — the top of the balance cock screw.

Results

Under 13 A : in order
Over 13 A : out of order
Proceed with the steps according to the Guide to Inspection and Repairs.

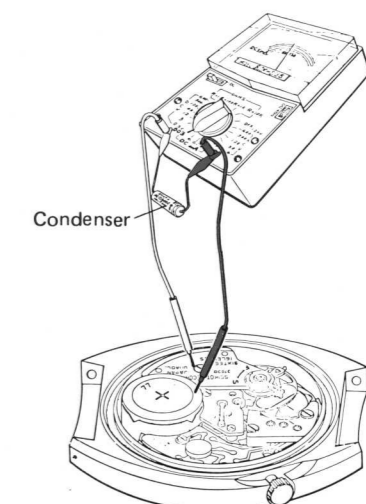
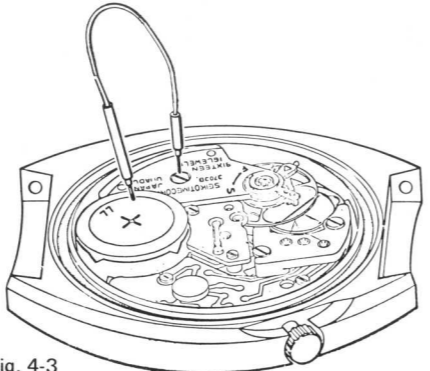

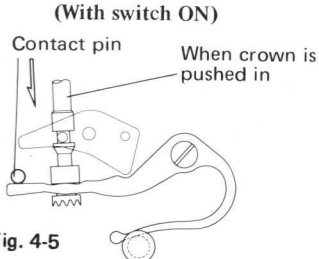
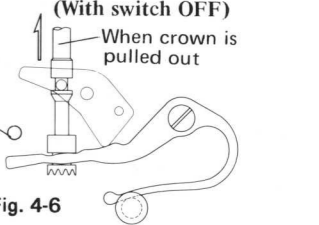
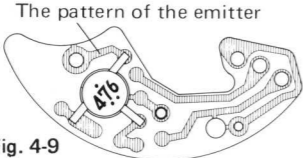
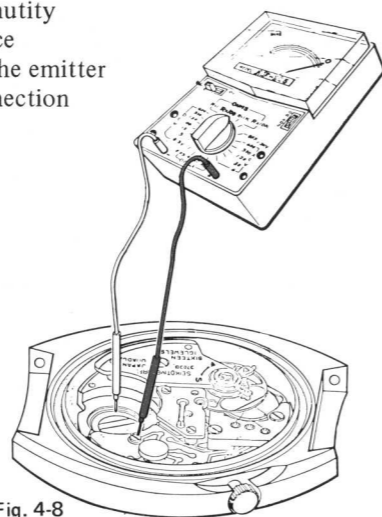
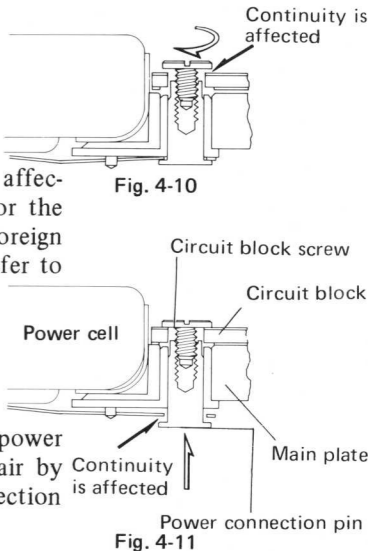

Fig. 4-2

3703B Inspecting continuity of the contact point and electronic circuit and their repair procedures

	Procedures	Results	Adjustment and repairs
C. Inspecting and Repairing Continuity of the Holding Spring for Power Cell	<p>Check of continuity between the power cell and the holding spring for the power cell.</p> <p>1) Push the crown (switch ON) 2) Using one piece of a lead plug One end—the (+) surface of the power cell The other end—the top of the balance cock.</p>  <p style="text-align: center;">Fig. 4-3</p>	<ul style="list-style-type: none"> ● The balance complete with stud begins to work. (Continuity of holding spring for power cell is affected.) ● The balance complete with stud will not work. (Parts other than the holding spring for power cell are out of order.) 	<ul style="list-style-type: none"> ● Adjust the holding spring for power cell so that it contacts with the power cell. ● To improve continuity, wipe the power cell and the holding spring for power cell with a cloth moistened in benzene or thinner. ● Proceed to inspection D
D. Inspecting and Repairing Continuity of the Switch	<p>Check the switch for continuity</p> <p>1) Set the tester for measuring resistance (+) lead plug—the top of the balance cock (-) lead plug—the contact pin.</p>  <p style="text-align: center;">Fig. 4-4</p>	<ul style="list-style-type: none"> ● When the crown is pushed in (switch ON) <ul style="list-style-type: none"> 0 Ω — Normal Over 0 Ω — The contact of switch is affected ● When the crown is pulled out (switch OFF) <ul style="list-style-type: none"> Over 2M Ω — Normal Under 2M Ω — Integrated block is out of order 	<ul style="list-style-type: none"> ● Proceed to inspection E ● Remove foreign objects, oil, and so on adhering to the contact pin and the top of the clutch lever. If the contact is still affected, the operation of the clutch lever is considered to be out of order. Check the play of clutch lever. Do not bend the contact pin; a bending contact pin will cause the malfunction of the circuit. ● If the switch is not completely OFF despite the fact that the contact pin is detached from the clutch lever (under 2M Ω), consider the circuit block is as affected. Replace the  <p style="text-align: right;">(With switch ON) Contact pin When crown is pushed in Fig. 4-5</p>  <p style="text-align: right;">(With switch OFF) When crown is pulled out Contact pin Fig. 4-6</p>
E. Inspecting and Repairing Continuity of the Power Connection	<p>Check the power connection for continuity</p> <p>Set the tester for measuring resistance (+) lead-plug—the pattern of the emitter (-) lead-plug—the power connection</p>  <p style="text-align: center;">Fig. 4-9</p>  <p style="text-align: center;">Fig. 4-8</p>	<ul style="list-style-type: none"> ● Meter indicates 0 — Normal ● Meter reads other than 0 — Out of order <p style="text-align: center;">Apply the lead plugs as under (Fig. 4.8) (+) lead plug — circuit block screw (-) lead plug — power connection</p> <ul style="list-style-type: none"> ● Meter reads 0 Ω ● When meter reading is other than 0 Ω 	<ul style="list-style-type: none"> ● Proceed to inspection F ● The power connection is considered to be affected by an insufficiently tightened screw or the adhesion of foreign matter; remove the foreign matter and tighten the screw securely. (Refer to Fig. 4-10) ● Contact of the power connection and the power connection setting-screw is affected. Repair by tapping the power connection pin in direction shown in Fig. 4.11.  <p style="text-align: right;">Continuity is affected Fig. 4-10</p> <p style="text-align: right;">Circuit block screw Circuit block Power cell Main plate Continuity is affected Power connection pin Fig. 4-11</p>

3703B Inspecting continuity of the contact point and electronic circuit and their repair procedures

F. Inspecting and Repairing the Integrated Block

When inspecting the integrated block, initially conduct the inspection mentioned in F-1. If the result of measurements according to F-1 reveals larger or smaller resistance values, inspect only the coil block mentioned in F-2 to make adjustments.

F-1. Inspecting the integrated block

This inspection is to check the integrated block (combination of circuit block and coil block) for continuity.

Procedures

1. Set the tester for measuring resistance from 0 to 10k Ω
2. Measurement:
 - Measure the resistance between A-B and A-C of the circuit block pattern.
 - a) Resistance between A-B
 - (+) lead plug — pattern A of the circuit block
 - (-) lead plug — pattern B
 - b) Resistance between A-C
 - (+) lead plug — pattern A of the circuit block
 - (-) lead plug — pattern C

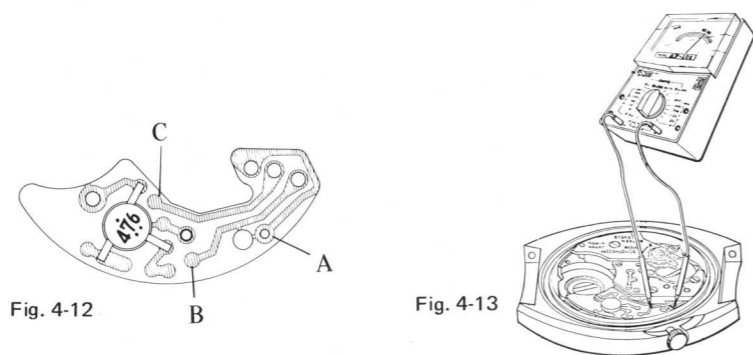

- Results**
- Large resistance value—Proceed to F-2 (Inspecting the coil block)
 - A-B: over 7k Ω
 - A-C: over 2.0k Ω
 - Small resistance value—Proceed to F-2 (Inspecting the coil block)
 - A-B: under 4k Ω
 - A-C: under 0.5k Ω
 - A-B: 4 to 7k Ω
 - A-C: 0.5 to 2.0k Ω

F-2. Inspecting the coil block

(when the result of F-1 shows larger or smaller resistance values)

Procedure

1. Remove three terminal screw of integrated block to separate the coil block.
2. Set the tester for measuring resistance from 2 to 15k Ω
3. Measurement
 - Measure resistance between the terminal screw pins B-C.
 - (+) lead plug — the tube for terminal screw B
 - (-) lead plug — the tube for terminal screw C

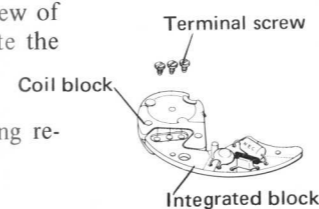

Fig. 4-14

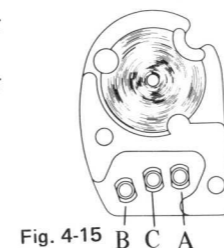

Fig. 4-15

Results

- (1) 4.5 to 9.0 k Ω
- (2) over 9.0 k Ω
- (3) under 4.5k Ω
- (4) 4.5 to 9.0k Ω

Adjustments

Connection between the coil block and the circuit block is defective. Adjust it as follows:

- 1) Securely tighten the terminal screw of integrated block.
- 2) Clean the pattern of the circuit block (arrow portion in Fig. 4.17)

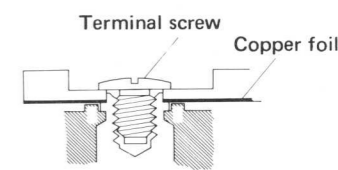

Fig. 4-16

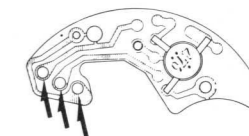

Fig. 4-17

Replace the coil block (the coil is either disconnected or shorted).

Be careful of these points when replacing the coil

- 1) Check the new coil
 - If the top of the tube for terminal screw is located lower than the coil board surface, scrape a little off the oblique lined portion (coil board) as shown in Fig. 4.19 to make it lower than the tube for terminal screw (so that it conforms to the correct position shown in Fig. 4.16).
- 2) Securely tighten the three terminal screws of the integrated block.

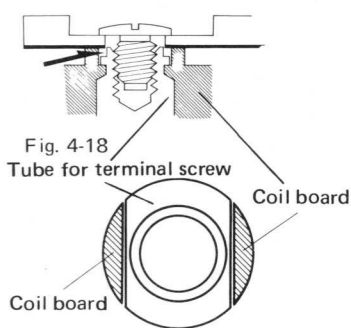
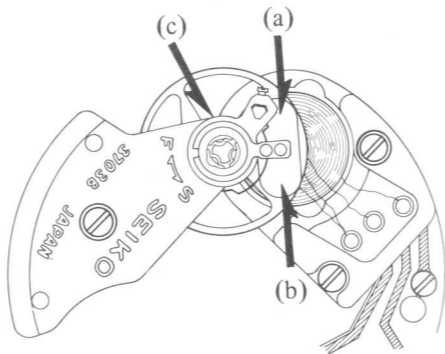
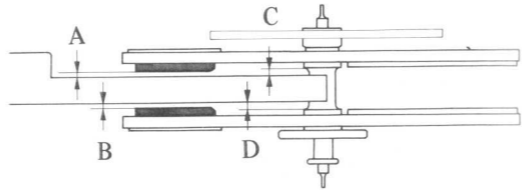
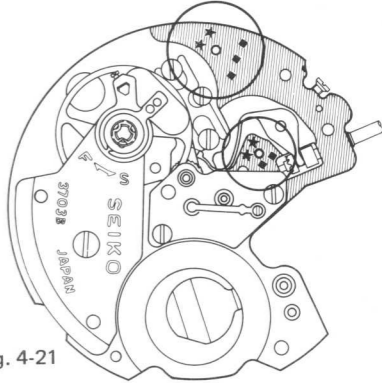
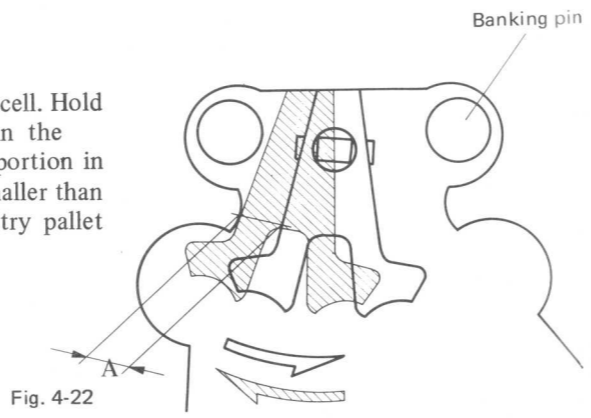
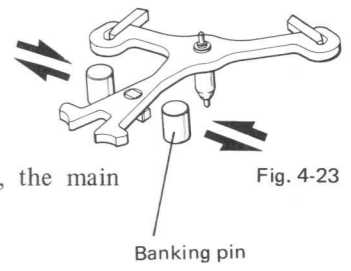

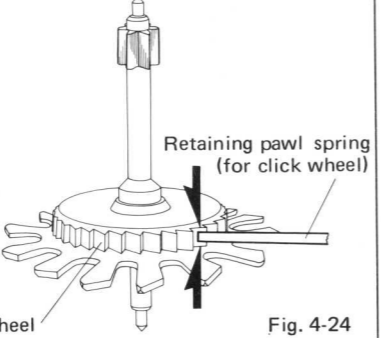
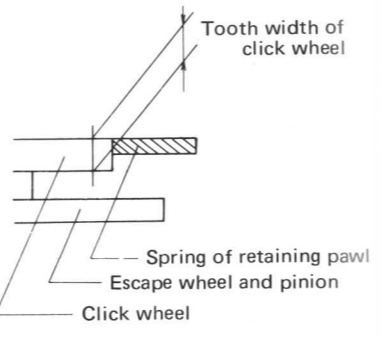

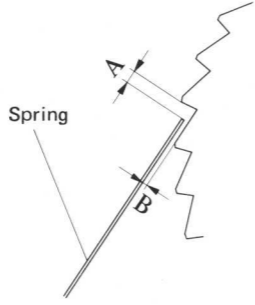
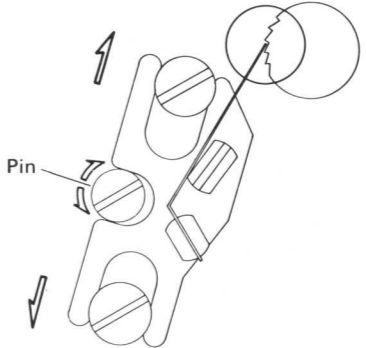
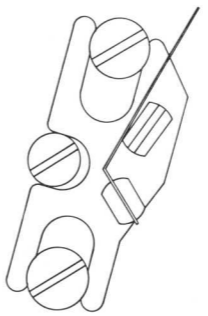

Fig. 4-19

Replace the circuit block (the circuit is out of order).

- 1) Wipe new circuit pattern with a cloth moistened alcohol.
- 2) Securely tighten the terminal screw of the integrated block.

	Procedures	Results	Adjustments
G. Inspecting and Adjusting Clearance Between the Balance Complete with Stud and the Coil	<p>This inspection is to confirm if the clearance between the balance wheel and the coil is normal. If the clearance is too small and they are rubbing together, the watch will not keep accurate time or it will cause stopping.</p> <p>Inspection</p> <p>Inspect the movement which is mounted with the balance wheel and the coil.</p> <p>1) Measure the clearance between the balance wheel and the coil at the two points (a) and (b), as shown in Fig. 4-19; measure the clearance A (upper) and B (lower) at point (a) and (b) as shown in Fig. 4-20.</p> <p>2) Measure the clearance between the balance staff and the coil at point (c), shown in Fig. 19; measure clearances C (upper) and D (lower), as shown in Fig. 20.</p>  <p>Fig. 4-19</p>  <p>Fig. 4-20</p>	<ul style="list-style-type: none"> • Each clearance A, B, C, and D is over 10/100mm: normal • Each clearance A, B, C, and D is under 10/100mm: abnormal 	<p>Proceed to step inspection H</p> <p>If the clearance is small, or if the balance wheel and the coil or the balance staff and the coil are rubbing together, repair as follows:</p> <ol style="list-style-type: none"> 1) Adjust the shake of the balance wheel to become a little bit smaller. Adjust the balance wheel so that the shake amount is 2/100 to 4/100mm as shown in Fig. 4.21 2) Adjust height of the coil. Remove the integrated block from the movement and adjust the lower plate. <ul style="list-style-type: none"> a) When raising the coil, tap the ★ portions of the main plate with a chisel shown in Fig. 4-21. b) When lowering the coil, tap the ■ marked portions of the main plate shown in Fig. 4-21.  <p>Fig. 4-21</p>
H. Inspecting and Adjusting the Drawing Force of Jewelled Pallet Fork and Staff	<p>This inspection is to confirm if the drawing force of the jewelled pallet is normal.</p> <p>If the magnitude and symmetry of the drawing force get out of order, the following abnormalities will result:</p> <ol style="list-style-type: none"> 1) The amplitude will change and give rise to wrong timing. 2) The current consumption will increase so that durability of the power cell is affected. <p>Inspection</p> <p>Assemble the pallet fork and staff and remove the power cell. Hold the lever end with non-magnetic tweezers and move it in the direction (Fig. 4.22) from the rest position (oblique lined portion in Fig. 4.22) by the amount of A (about 30/100mm, a little smaller than the fork slot width). (Follow this procedure as to the entry pallet jewel side and the exit pallet jewel side.)</p>  <p>Fig. 4-22</p>	<ul style="list-style-type: none"> • The lever returns to its original position. (Oblique lined portion in Fig. 4.22.) Normal • The lever will not return to its original position. Abnormal 	<p>Proceed to step inspection I</p> <ol style="list-style-type: none"> 1) Adjust by bending the banking pin driven into the main plate in the direction, shown in Fig. 4.23. 2) If the jewelled pallet fork and staff is asymmetrical, adjust the banking pin only on the asymmetrical side. 3) If the asymmetry cannot be adjusted by bending the banking pin, replace the jewelled pallet fork and staff. 4) When replacing it, check its drawing force.  <p>Fig. 4-23</p> <p>Note: If the banking pin is broken, the main plate will be affected.</p>

3703B Inspecting the retaining pawl

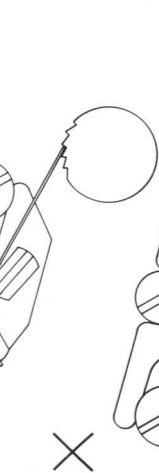
Procedures	Results	Adjustments and repairs
<p>This inspection is to confirm if the spring of the retaining pawl (for click wheel) is normal.</p> <p>If the spring force is excessive, the loss of wheel torque will be increased and escapement efficiency will be affected. If the spring force is too weak, the spring will not function. If the spring is not in position, the operation of the escapement will be affected.</p> <p>Inspection</p> <p>1) Confirm if the tip of the spring for retaining pawl is within the tooth width of the click wheel; arrowed portion shown in Fig. 4.24.</p> <div style="text-align: center;">  <p>Retaining pawl spring (for click wheel)</p> <p>Click wheel</p> <p>Fig. 4-24</p> </div>	<ul style="list-style-type: none"> ● Within the tooth width — Normal ● Out of the tooth width — Abnormal <div style="text-align: center;">  <p>Tooth width of click wheel</p> <p>Spring of retaining pawl</p> <p>Escape wheel and pinion</p> <p>Click wheel</p> </div>	<p>Hold the tip of the spring for retaining pawl with tweezers and adjust the spring by bending it as shown in Fig. 4.25.</p> <div style="text-align: center;">  <p>Fig. 4-25</p> </div>
<p>2) Check the contacting amount A of the retaining pawl with the click wheel.</p> <p>Note: When turning the click wheel by operating the jewelled pallet to the right and left, the tip of the spring must drop from the tooth crest of the click wheel.</p> <p>When measuring dimensions A and B (Fig. 4.26), adjust so that the pallet jewel contacts the tooth face and the flank of the escape wheel and pinion when stopped.</p> <div style="text-align: center;">  <p>Spring</p> <p>B</p> <p>Fig. 4-26</p> </div>	<p>Dimension A</p> <ul style="list-style-type: none"> ● Approx. thickness of spring — Normal ● Other than thickness of spring — Abnormal 	<p>Adjust by turning the pin (Fig. 4.27) driven into the main plate, in the stopping condition of the jewelled pallet fork and staff.</p> <div style="text-align: center;">  <p>Pin</p> <p>Fig. 4-27</p> </div> <p>Note: (1) When the spring of the retaining pawl has been adjusted, check it for its relation with the jewelled pallet fork and staff in accordance with the disassembling and reassembling procedures given in 3.3703B-4.</p> <p>(2) When each item of adjustment has been completed, check the jewelled pallet for overall balance.</p>
<p>3) Check clearance B between the retaining pawl and the click wheel (inspection of spring force) shown in Fig. 4.26.</p>	<p>Dimension B</p> <ul style="list-style-type: none"> ● Approx. thickness of spring — Normal ● Other than thickness of spring — Abnormal 	<p>Adjust by turning the adjusting pin for the retaining pawl in stopping condition of the jewelled pallet fork and staff.</p> <div style="text-align: center;">  <p>Adjusting pin</p> <p>Fig. 4-28</p> </div> <div style="display: flex; justify-content: space-around; align-items: flex-end;"> <div style="text-align: center;">  <p>Fig. 4-29 (Normal)</p> </div> <div style="text-align: center;">  <p>Fig. 2-30 (Too strong)</p> </div> <div style="text-align: center;">  <p>Fig. 2-31 (Too weak)</p> </div> </div>