

PARTS CATALOGUE/TECHNICAL GUIDE

Cal. 7D48A

【SPECIFICATIONS】

Item	Cal. No.	7D48A
Movement		
Movement size	Outside diameter	φ 32.0 mm
	Casing diameter	φ 30. 0 mm
	Height	6.1 mm
Time indication (Movement intervals)		3 hands (Hour and minute hands: 5-second interval movement, Second hand: 1-second interval movement), 24-hour hand
		Calendar Year indication: Indication disk for year Month indication: :Month indicator Date indication: Big calendar
Driving system		Step motor: 2 pieces · Piezoelectric motor (for calendar)
Additional mechanism		Automatic generating system Energy depletion forewarning function Overcharge prevention function Electronic circuit reset switch Train wheel setting device Instant setting device for date calendar Automatic power save function Time relay function Perpetual calendar (Year • Month • Date) up to February 28, 2100
Loss/gain		Monthly rate at normal temperature range: less than 15 seconds
Regulation system		Nil
Measuring gate by quartz tester		Use 10-second gate.
Power supply	Power generator	Automatic generating system
	Electricity storage Unit (E.S. Unit)	Titanium lithium ion rechargeable battery
Operating voltage range		0.45 v ~ 2.5 v
Continuous operating time		Operable time of time relay function: approximately 4 years if fully charged
Jewels		16 jewels

SEIKO WATCH CORPORATION

REMARKS ON REPAIRING CAL. 7D48A

Cal. 7D48A is an Automatic Generating System analog quartz watch equipped with piezoelectric motor, featuring the perpetual calendar and automatic adjustment function. Although Cal.7D48A features new functions, the experience of repairing the existing KNETIC series watches will be helpful.

In repairing Cal. 7D48A, you are requested to have the full knowledge of its functions and strictly observe the repairing and checking instructions provided in this guide so that the watch will be repaired correctly.

FEATURES OF CAL. 7D48A

Cal. 7D48A features the power save function that automatically stops the hands from moving if the watch is left untouched for a certain period of time. Even if the watch is in this state, the perpetual calendar continues to count the date until the stored electrical energy is depleted. When you decide to use it again, swinging the watch several times will activate the time relay function, which starts the hands moving quickly to indicate the correct time and resume the normal operation. Cal. 7D48A is an innovative KINETIC model; it conserves the stored electrical energy by stopping the hands while it is not in use, and, at the same time, it completely eliminates the cumbersome time setting procedure when it is used again.

1. POWER SAVE FUNCTION

- While the watch is not in use, the hands stop automatically to minimize the electrical energy consumed. This is called "the power save function". Though the hands stop, the built-in IC continues to compute the time, keeping the watch ready for the next use.

<The automatic power save function>

If the watch is left untouched for approximately 24 hours, the power save function is automatically activated.

2. TIME RELAY FUNCTION

- While the power saving function is working, the built-in IC continues to compute the time though the hands stop. As the watch detects a certain amount of electricity generated by swinging it, the hands are automatically adjusted to the time retained inside the watch, resuming the normal operation. This is called the "time relay function". As it is activated, the hour and minute hands are adjusted first, then, followed by the second hand.
- By only swinging the watch for 2 to 3 seconds, the time relay function will be activated.

(Caution)

- ◆ It may take approximately up to 64 seconds (32 seconds on average) to activate the time relay function.
- ◆ The accuracy of the time computation by the built-in IC is equivalent to that of conventional quartz watches. Especially when the watch has been left untouched for a long time before the time relay function is activated, the time indicated by the hands may include a certain amount of time loss or gain within the range of the accuracy of the watch (± 15 seconds per month) that has accumulated during that time.

3. CONTINUOUS OPERATING TIME

The continuous operating time varies depending on the stored electrical energy inside the watch. In the case that the fully charged watch enters the power save mode,

the time relay function of the watch remains operable for approximately four years.

(Caution)

If the stored electrical energy is completely depleted while the watch is in the power save mode, swinging the watch may not activate the time relay function. Instead, the second hand starts moving at two-second intervals.

4. PERPETUAL CALENDAR

The perpetual calendar automatically adjusts the date up to February 28, 2100. Even if the watch is in the power save mode, the calendar continues to function as normal.

(Caution)

- ◆ The date changes between 23:30 and 0:30.
- ◆ Normally it takes approximately 2 seconds for the watch to change the date. However it may take up to 2 minutes especially during the wintertime or when the stored electrical energy is being depleted.
- ◆ Even though the watch is reactivated after the stored electrical energy has become extremely low, the calendar can be easily adjusted manually.
- ◆ When the watch is in power save mode, and the date does not change correctly (or shows the wrong date), the electrical power stored in the rechargeable battery is being depleted. Before starting to wear the watch, recharge the watch until the second hand no longer moves at two-second intervals and then reset the time and calendar.

5. TIME AND CALENDAR SETTING

It is recommended that you adjust the time and/or calendar during the time between 1:00 and 23:00.

If you adjust the time and/or calendar around 0:00, the date may become incorrect, but this is not a malfunction.

When the watch moves at two-second intervals, the date stops changing.

When the watch no longer moves at two-second intervals after it is recharged, reset the calendar.

When the date is set to a non-existing date, such as February 30, the calendar automatically correct the date. (When the date is set to February 30, the calendar automatically shows March 1).

When the stored electrical energy is completely depleted, and the watch is stopped, recharge the watch until it no longer moves at 2-second intervals and reset the time and calendar.

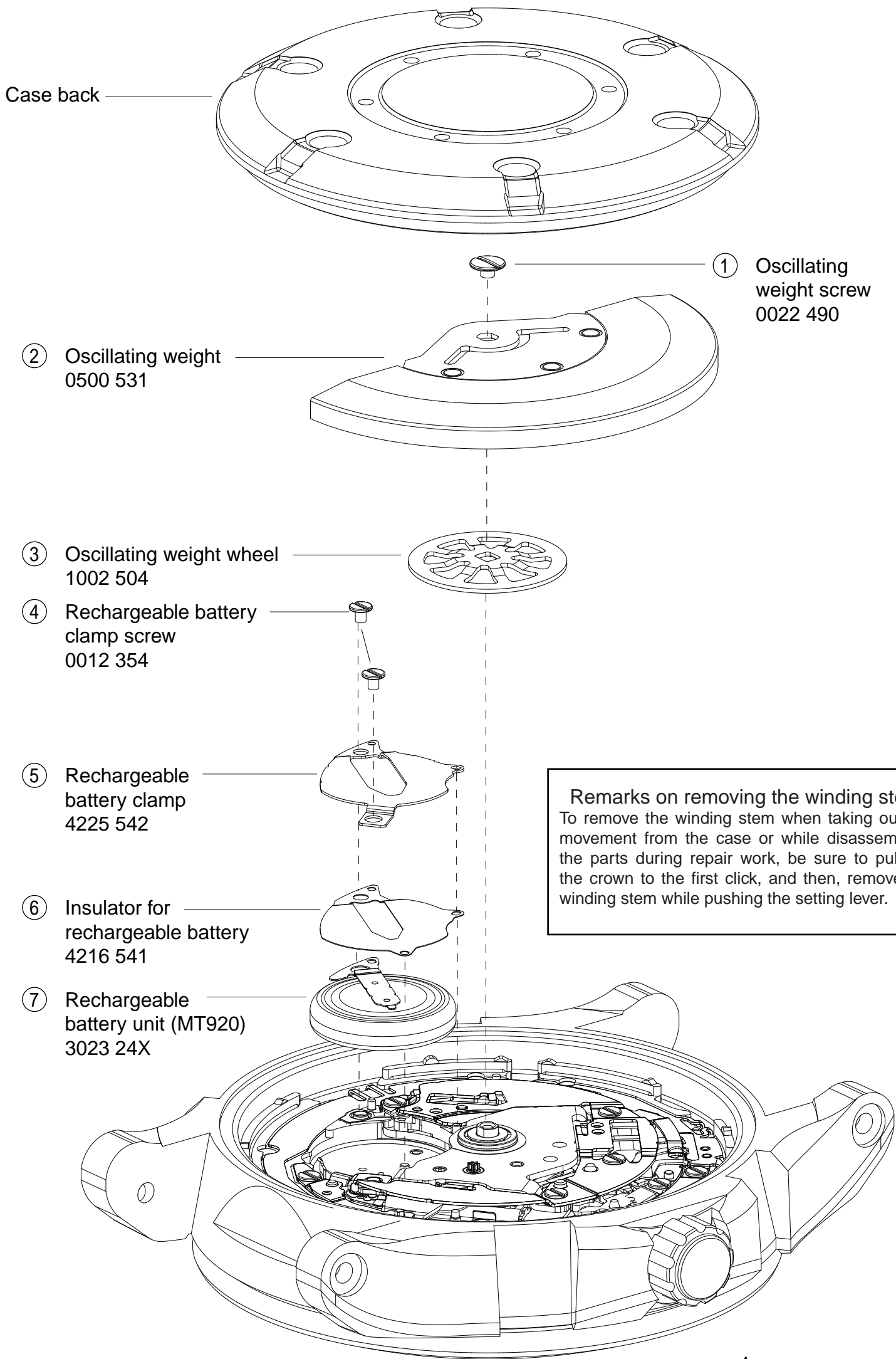

① Oscillating weight screw
0022 490

② Oscillating weight
0500 531

③ Oscillating weight wheel
1002 504

④ Rechargeable battery clamp screw
0012 354

⑤ Rechargeable battery clamp
4225 542

⑥ Insulator for rechargeable battery
4216 541

⑦ Rechargeable battery unit (MT920)
3023 24X

Remarks on removing the winding stem
To remove the winding stem when taking out the movement from the case or while disassembling the parts during repair work, be sure to pull out the crown to the first click, and then, remove the winding stem while pushing the setting lever.

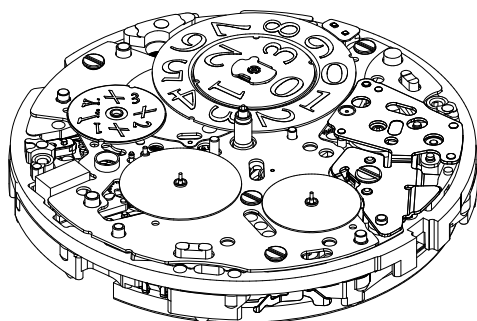
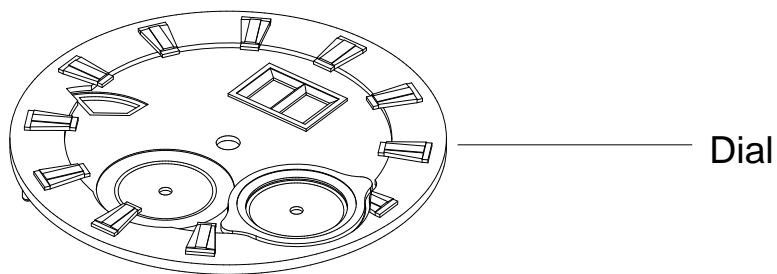
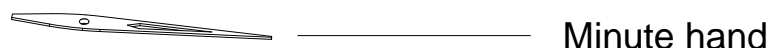
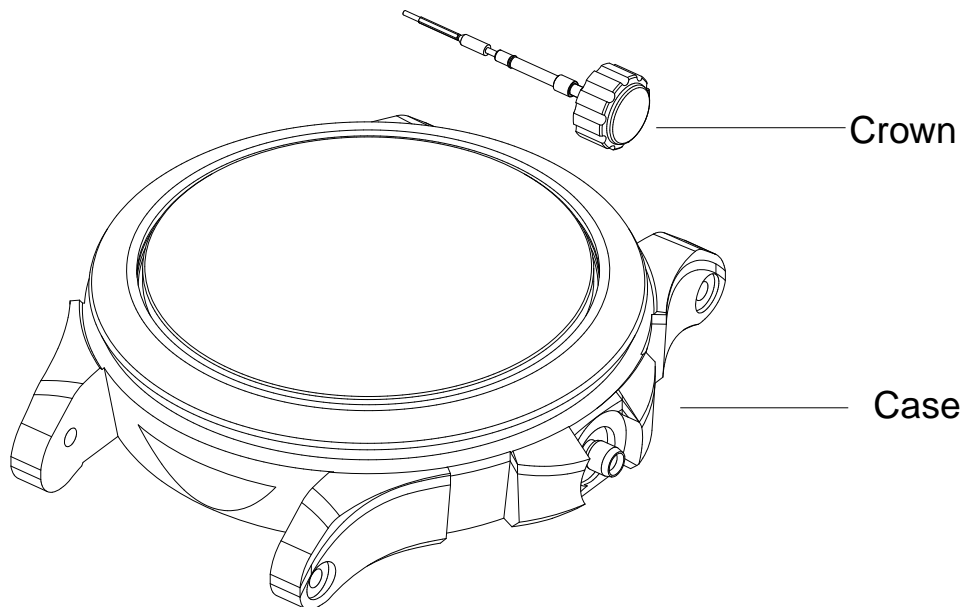

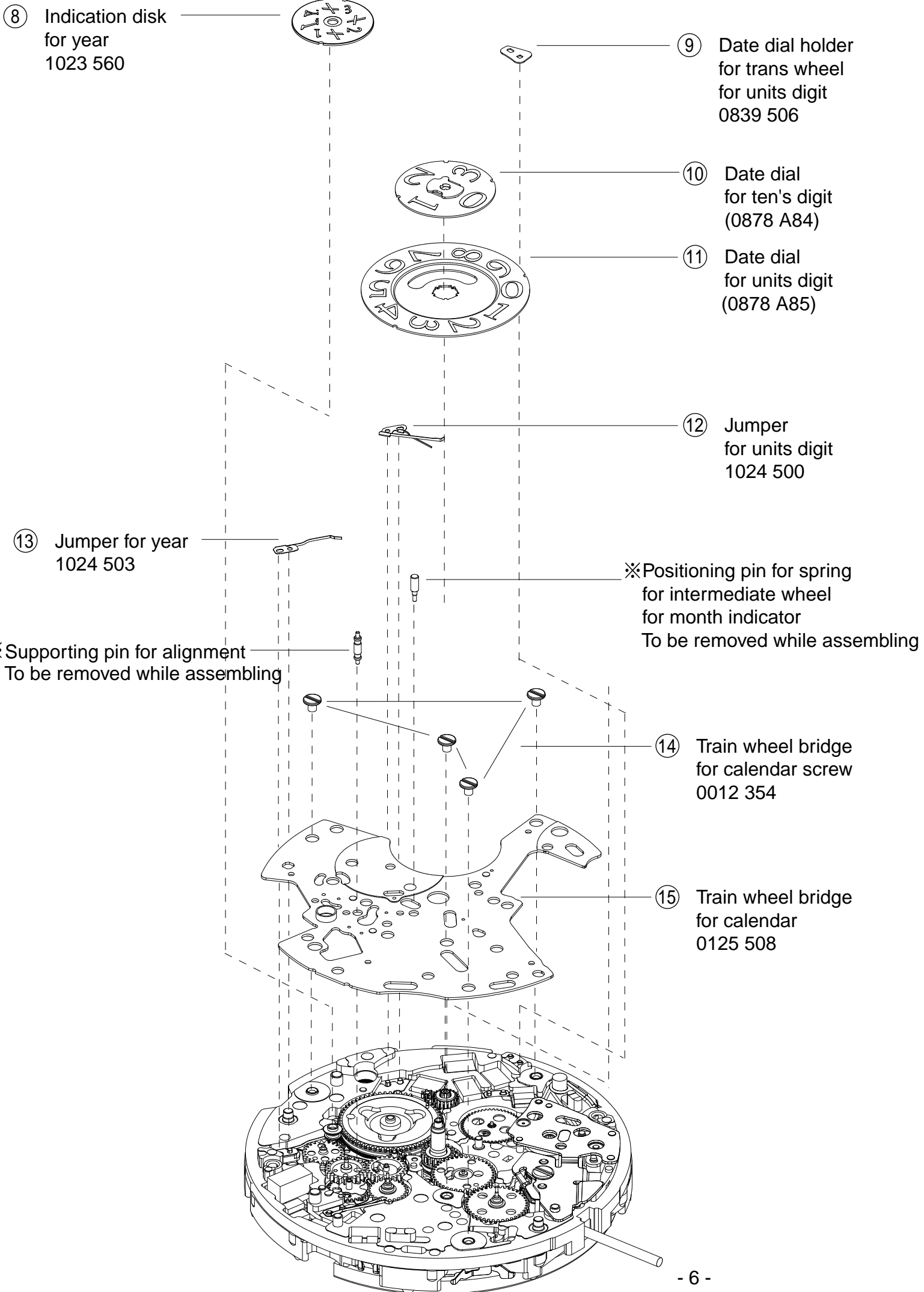

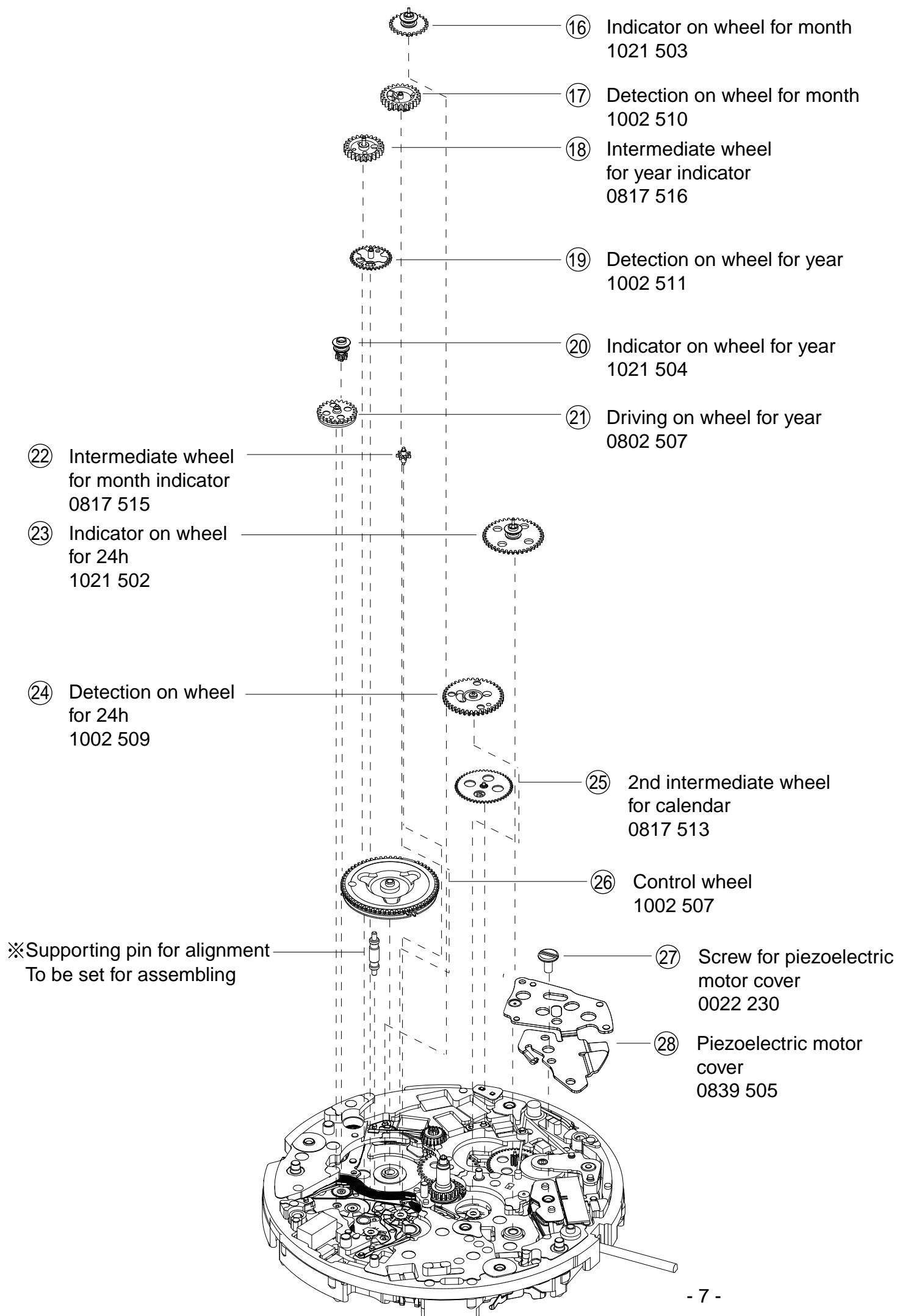

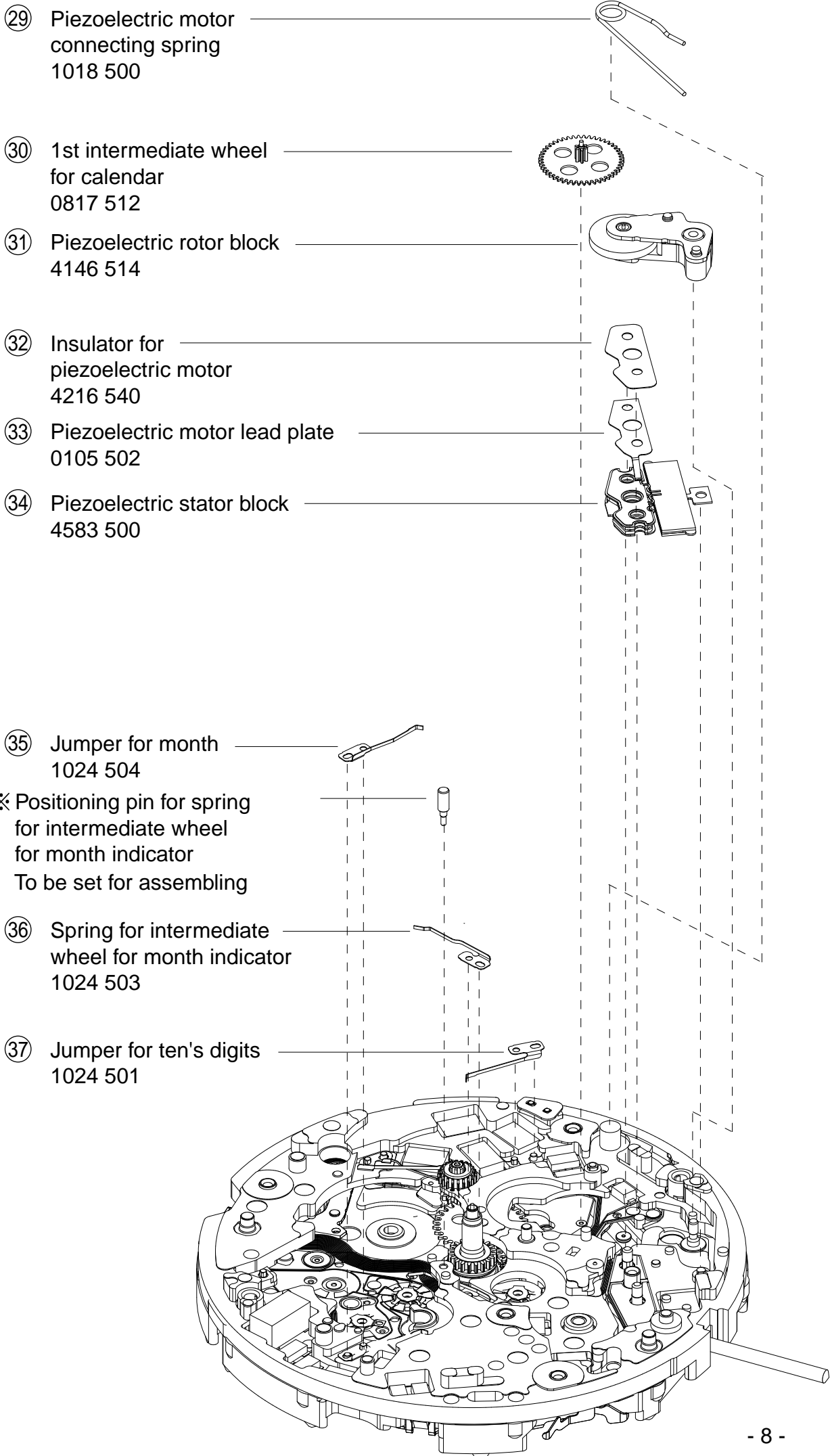

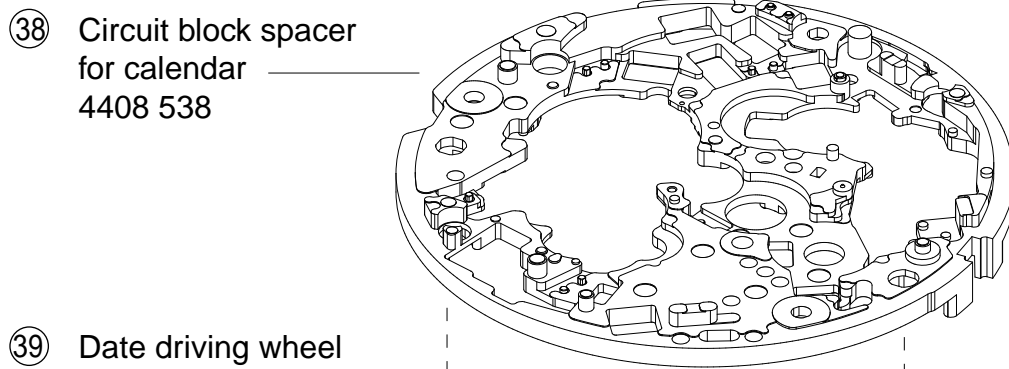

38 Circuit block spacer
for calendar
4408 538

39 Date driving wheel
for ten's digit
0802 506

40 Pinion
for ten's digit
1013 504

42 4th intermediate wheel
for calendar corrector
0962 502

44 Hour wheel
0271 564

45 Circuit block for calendar
4000 595

47 A connector
4313 581

49 Control jumper
1024 502

51 Contact point spring
4281 510

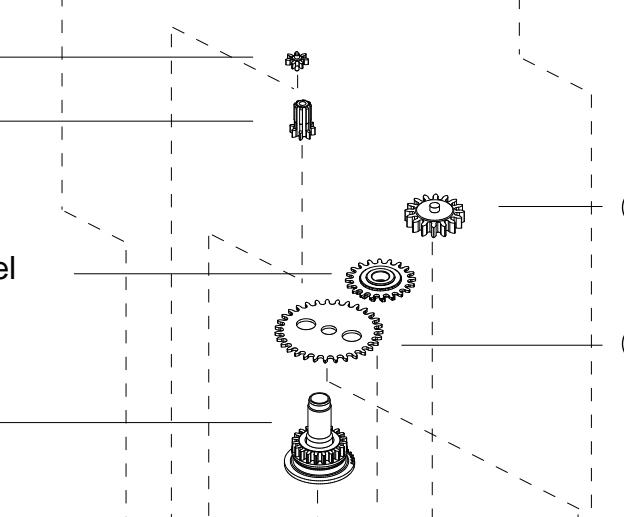

41 3rd intermediate wheel
for calendar corrector
0962 501

43 3rd intermediate wheel
for calendar
0817 514



46 B connector
4313 582

48 Ratchet lever
0981 500

50 2nd intermediate wheel
for calendar corrector
0962 559

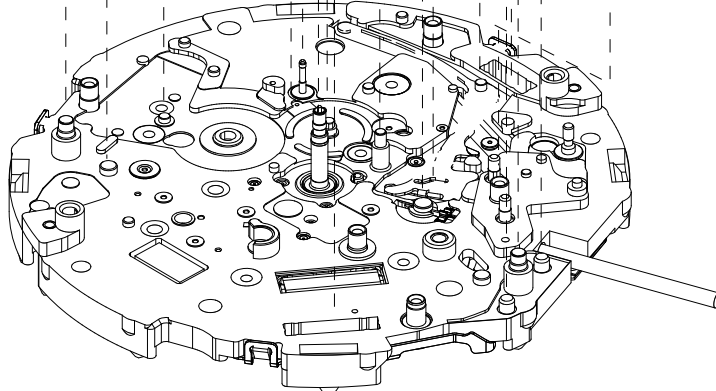
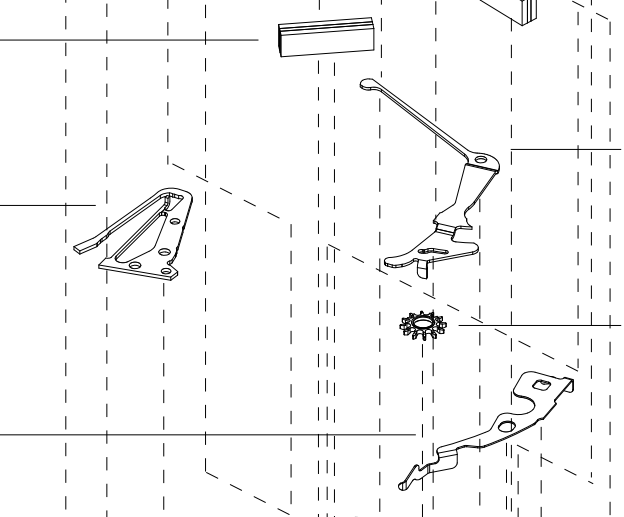

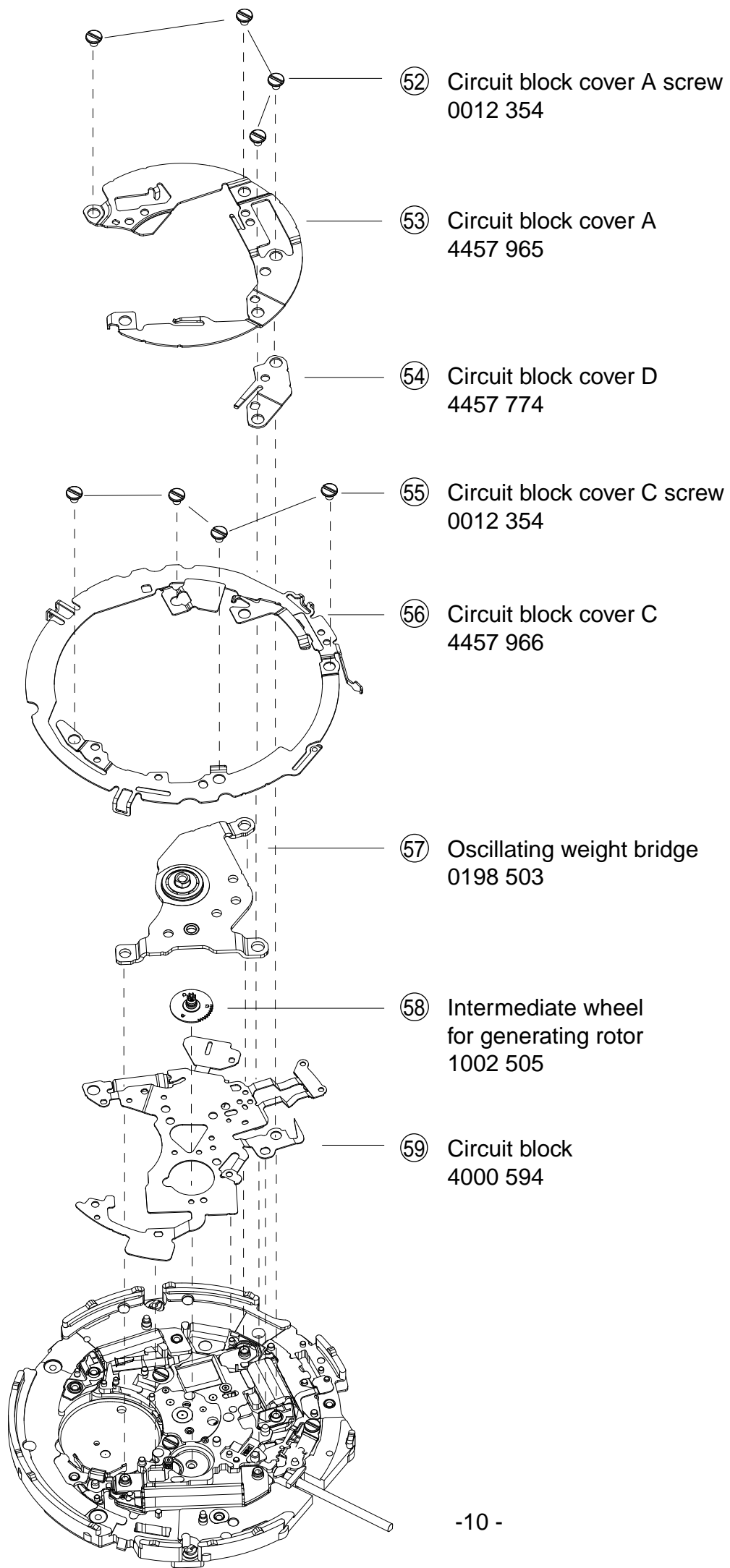

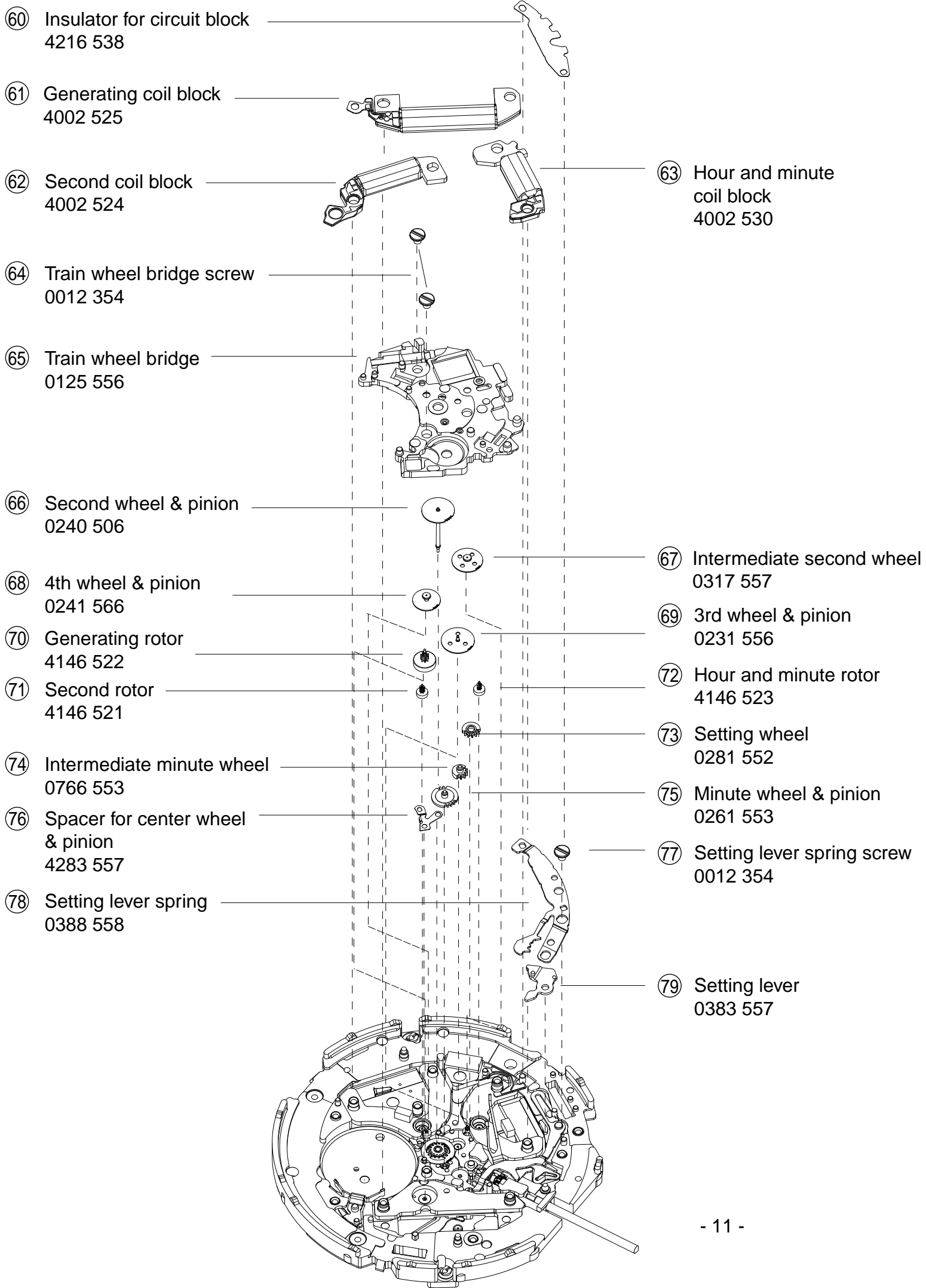

80 Yoke
0384 557

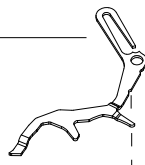

81 Train wheel setting lever
0391 557

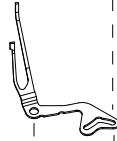

82 Center wheel
& pinion
0221 712



84 Clutch wheel
0282 523

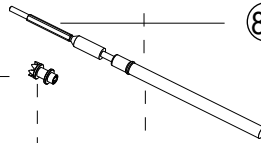

83 Winding stem
(0351 510)



85 1st intermediate wheel
for calendar corrector
0962 557

86 Rechargeable
battery connection(+)
4271 522



87 Generating stator
4239 527



88 Second stator
4239 523

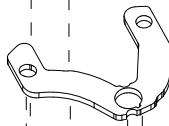

89 Hour and minute stator
4239 522

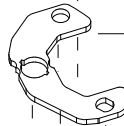

90 Lead pin for RZ1
0027 369



91 Main plate
0100 710

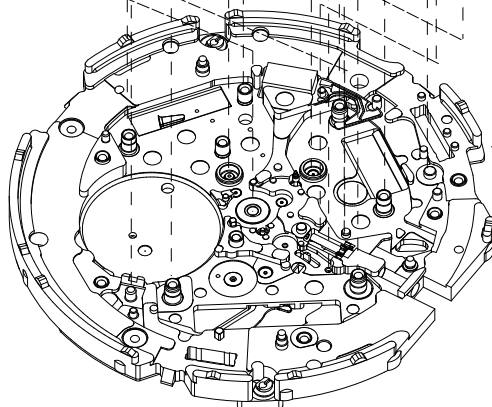

The explanation here is only for the particular points of Cal. 7D48A.
 For the repairing, checking and measuring procedures, refer to the “TECHNICAL GUIDE, GENERAL INSTRUCTIONS”.

I. STRUCTURE OF THE CIRCUIT BLOCK

⑤9 Circuit block



④5 Circuit block for calendar



II. REMARKS ON DISASSEMBLING AND REASSEMBLING

1. About “exclusive jig pin” used for assembly and disassembly

Cal. 7D48A employs a new structure for the calendar unit; therefore, it is necessary to set each gearwheel correctly when assembling. Consequently, two kinds of “exclusive jig pins” are available in consideration of efficiency in assembly performance. Be sure to use these “exclusive jig pins” for disassembly and assembly of the calendar unit.

* Be careful not to forget to remove and not to lose the “exclusive jig pin” when assembling is completed.

<How to use the exclusive jig pins>

◆ “Positioning pin for the spring for intermediate wheel for month indicator”

In assembly, set the “positioning pin for the spring for intermediate wheel for month indicator” after assembling the (38) jumper for ten’s digit, and remove it after assembling from the (37) spring for intermediate wheel for month indicator to the (15) train wheel bridge for calendar screws.

◆ “Supporting pin for alignment”

In assembly, set the “supporting pin for alignment” after assembling the (28) screw for the piezoelectric motor cover, and remove it after assembling from the (27) control wheel to the (15) train wheel bridge for calendar screws.

2. Precautions for jumpers on calendar unit when assembling and disassembling

Target parts:

- (35) Jumper for month, (36) Spring for intermediate wheel for month indicator
- (37) Jumper for ten’s digit, (12) Jumper for units digit, (13) Jumper for year

Precautions for disassembly and assembly

For disassembly: When individually disassembling the above parts, remove them with sufficient care since they are used at the points of engagement. Additionally, they can be disassembled even in a state attached to the circuit block spacer for calendar without individual disassembling.

For assembly: Check the points of engagement for rattle when assembling. If they rattle, replace the circuit block spacer for the calendar.

3. How to install the hands

Cal. 7D48 features the perpetual calendar. Thus, the hands should be carefully mounted exactly as instructed below.

1. Pull out the winding stem to the first click position, and set the calendar to “the leap year, January 1”

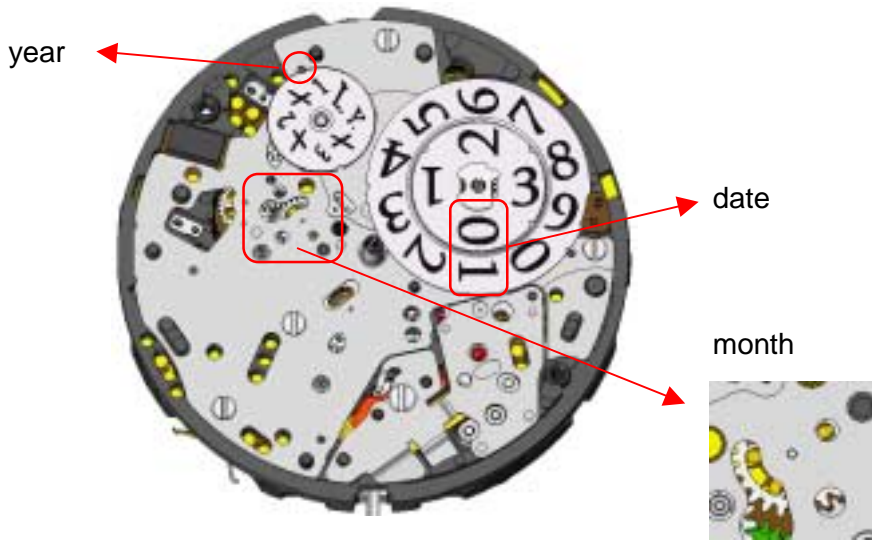

2. Pull out the winding stem to the second click position, and turn the crown to set the 24H contact point as illustrated below. (To correct the timing of date change)

*Connect the probes of testers to “A” and “B” portions. The 24H contact point will be adjusted, allowing for a check of date changing status.

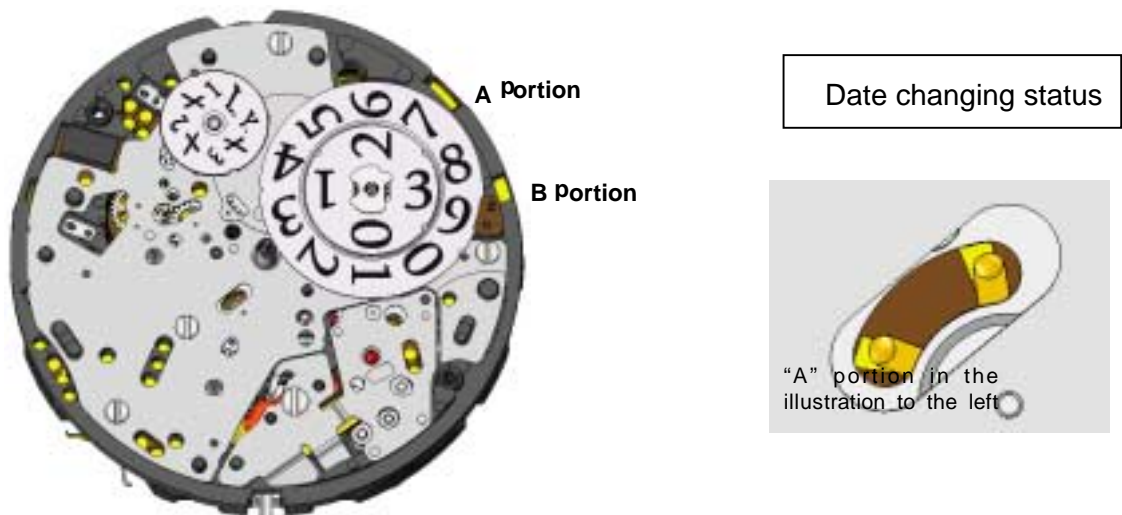

3. Keep the watch in this state when carrying out the installation of the hands in order of the 24-hour hand, month indicator, hour hand, minute hand and second hand.

* When removing the hands during repair work, ensure that the calendar is set to “the individual disassembling.” If the hands are removed with the calendar set to a date other than “the leap year, January 1”, the correct position of the year may be lost.

III. VALUE CHECKING AND ADJUSTMENT

●Coil block resistance

Second coil block:	2.00k	--	2.45k
Hour and minute coil block:			
Coil for driving hands:	1.00 k	--	1.25 k
Coil for detecting generation:	270	--	330
Generating coil block:	360	--	420

Note:

Measure the coil block resistance after installing each coil block to the movement, checking that stable measurements are obtained.

*The motor driving the hour and minute hands uses a special driving system so that they move quickly to indicate the current time immediately after the time relay function is activated. The hour and minute coil block has two layers of coils, one for driving the hands and the other for detecting generation, and it is necessary to measure the resistance of each coil layer.

•The illustration below shows the patterns to which the probes of the tester should be applied to measure the resistance of the respective coils.

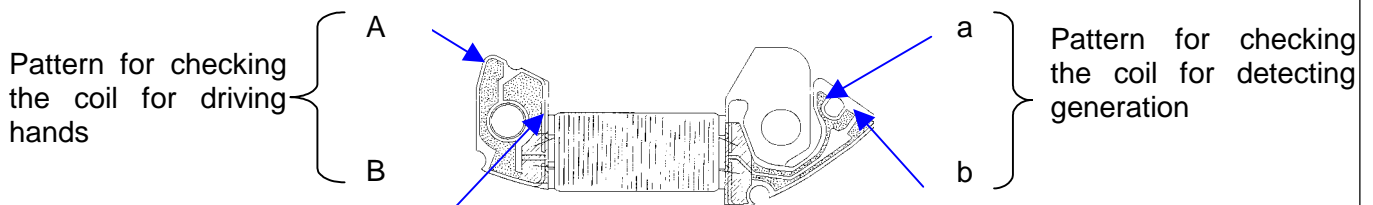

●Checking for leakage between coil for driving hands and coil for detecting generation

*If the hour and minute hands do not move properly when the time relay function is activated, that is, if they remain stopped or will not move smoothly, check for leakage between coil for driving hands and coil for detecting generation. This checking is required only if such a problem is found.

If leakage is detected, replace the hour and minute coil block with a new one.

● How to check the leakage

1. Make the tester ready for measuring the resistance.
2. Apply the probes of the tester to 1 "A" and "a", 2 "A" and "b", 3 "B" and "a", and 4 "B" and "b", respectively, to measure the resistance.
3. If the four measurements obtained are all infinitely great, that is, if the resistance is unable to be measured for all the four cases, there is no leakage between coil for driving hands and coil for detecting generation. As a guideline, there is leakage if measurements of less than 2 k are obtained.

Generating coil block resistance

340 - 440

Note: Measure the generating coil block resistance after installing it to the movement, checking that stable measurements are obtained.

● Current consumption

For the whole movement (while the hands are moving):

Less than $0.70 \mu\text{A}$ (with 1.55 V supplied from a battery)

For the circuit block alone:

Less than $0.40 \mu\text{A}$ (with 1.55 V supplied from a battery)

● How to measure the current consumption for the whole movement (while the hands are moving)

1. Disassemble unnecessary parts to make the movement ready for the measurement. Follow the disassembling procedure illustrated in this manual until you remove the rechargeable battery unit, and then, reassemble the oscillating weight. As a result, the rechargeable battery unit, insulator for rechargeable battery and rechargeable battery clamp are removed from the movement.
2. Apply the minus terminal to "a" portion in the illustration and plus terminal to the circuit block cover A, respectively.

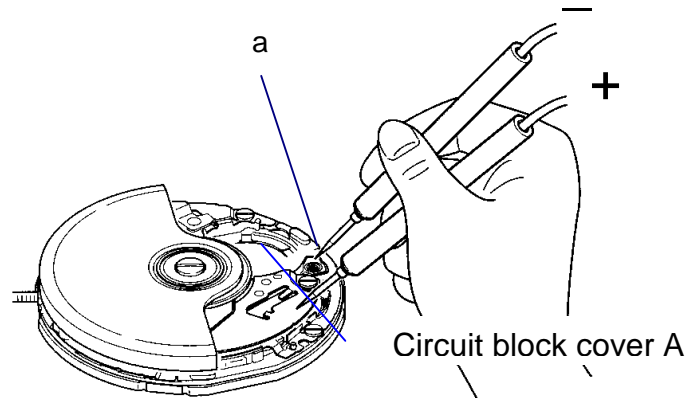

3. For a few seconds after the probes of the tester are applied to the movement, the IC is in the quick start mode, and current consumption cannot be measured properly. To switch the IC from the quick start to the normal hand movement mode, move the oscillating weight from side to side continuously for more than three seconds with the tester connected to the movement. (The IC will detect the electricity generation and will be switched to the normal hand movement mode.)

Note

When moving the oscillating weight from side to side, take care lest the minus terminal of the tester touches the oscillating weight.

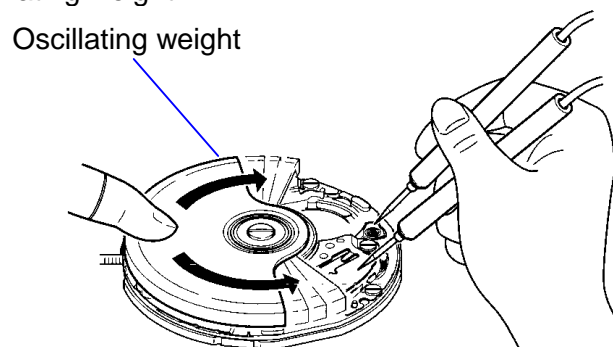

4. After checking that the IC has been switched to the normal hand movement mode and a stable measurement can be obtained, read the measurement. (If the measurement value remains high or unstable, repeat step "3" above.)

Notes:

* Light may increase the current consumption, resulting in an inaccurate measurement. If the current consumption exceeds the standard value, protect the movement from light with a black cloth or the like after following step "3" above, and make a measurement again.

* When the current consumption for the whole movement exceeds the standard value while the current consumption for the circuit block alone is within the standard value range, a driving pulse may be generated to compensate for the heavy load applied on the gear train, etc. In that case, overhaul and clean the movement parts, and then, measure the current consumption for the whole movement again.

● How to measure the current consumption for the circuit block alone

1. Connect the tester to the circuit block as shown in the illustration.

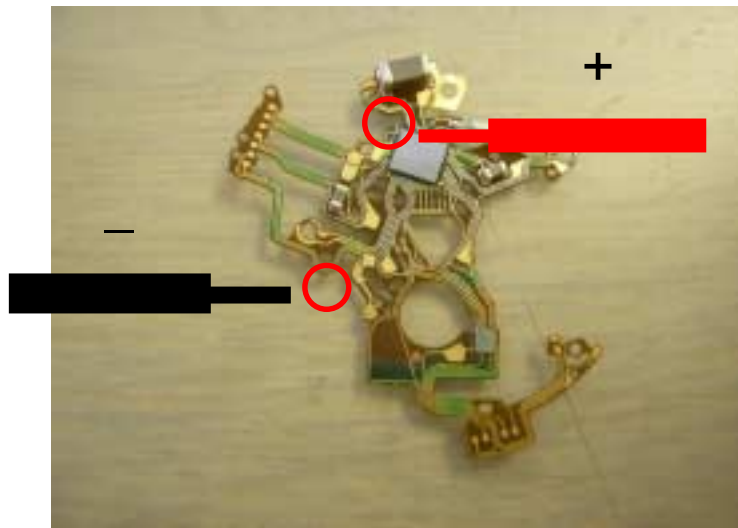

2. Checking that a stable measurement is obtained, read the current consumption.
(If the measurement value remains high or unstable, repeat step "2" above.)

Notes:

* The current consumption measurement for the circuit block alone is particularly susceptible to light, and a value higher than the actual measurement may be obtained if the circuit block is exposed to light. Protect the circuit from light with a black cloth or the like after following step "2" above, and then, measure the current consumption.

* If the current consumption for the circuit block alone exceeds the standard value, the duration of the charge will be shorter than specified. In that case, replace the circuit block with a new one.

● Checking the automatic generating system

1. Apply the probes of the tester as shown in the illustration, and measure the voltage of the rechargeable battery. (The obtained voltage is called the "initial voltage".)

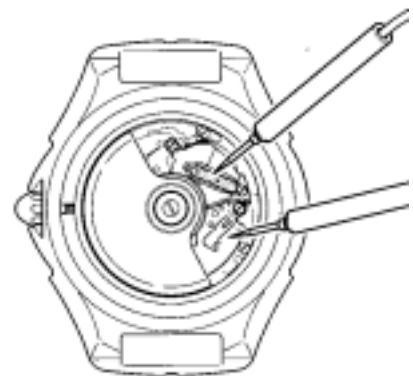

Notes:

- ◆ When applying the minus probe of the tester to the rechargeable battery, take care not to short-circuit the lead terminal (-) and the rechargeable battery clamp.
- ◆ If a short-circuit has occurred, leave the watch untouched for more than ten minutes, and measure the voltage again, checking that a stable measurement is obtained.

2. Close the case back tentatively, and swing the watch from side to side 200 times at a rate of 2 to 3 swings a second, making an arc of approximately 20 cm.



3. Within 3 minutes after swinging the watch, measure the voltage of the rechargeable battery in the same manner as in step “1” above.
4. Refer to the table below, and decide whether the automatic generating system is normal or defective.

[Initial voltage and guidelines of normal/defective decision]

Initial voltage	Guidelines of normal/defective decision
0.45 ~ 1.0 V	After charging, the voltage of rechargeable battery has increased 0.1 V or more from the initial voltage.
1.01 ~ 1.2V	After charging, the voltage of rechargeable battery has increased 0.05 V or more from the initial voltage.

- * The guidelines specified in the above table apply only when the initial voltage is within the range between 0.45 V and 1.2 V.
- * The amount of electricity generated by swinging the watch varies depending on the manner in which you swing it, such as the rate of swinging and the size of the swinging arc. Please note, therefore, that checking through the procedure above provides only a guideline for normal/defective decision.

<For your information>

1. Number of swings and power reserve
 - ◆ When the power reserve inn the rechargeable battery is depleted and the watch stops completely, swinging it approximately 500 times at a rate of 2 to 3 times a second will start the second hand moving at normal one-second intervals in stead of two-second intervals. If the second hand still moves at two-second intervals after 500 swings, swing the watch further until it moves at one-second intervals.
 - ◆ While the second hand is moving at one-second intervals, swing the watch further until it moves at one-second intervals.
2. The number of days over which the watch is worn and power reserve
 - ◆ Wearing the watch continuously for 12 hours will accumulate approximately one and a half additional days of power reserve.
(Example)
If you wear the watch every day for 12 hours over a period of a week, approximately 10 days of power reserve will be secured in the rechargeable battery. While the power saving function is in operation and the hands are stopped, this amount of power reserve will keep the watch operating for approximately 2 months.

Inspection of perpetual calendar and PTP operation in move state

Cal. 7D48A is equipped with a perpetual calendar which automatically advances the calendar up to February 28, 2100.

Here, an inspection is carried out if the “perpetual calendar” operates normally.

Note:

This inspection cannot be made when the watch is stopped. If the watch to be inspected has stopped, start the inspection after the second hand starts moving at 1-second interval by manually charging it and the amount of stored electrical energy reaches above 1.3v.

▪ Inspection method of PTP operation in move state

1. Recharge the rechargeable battery until the amount of stored electrical energy reaches above 1.3v.
2. After tightening the (28) screw for the piezoelectric motor cover, pull out the crown from the “0” position to the first click position and leave it as it is for two seconds or longer. Then, “Pull the crown out and push it back in the order of the “0” position, first click position, “0” position, first click position and “0” position, and return it to the normal position.” Carry out this operation within one second.
3. Check that the (32) piezoelectric rotor rotates smoothly. (Normal operation)
If it rotates smoothly, PTP operation is normal.
4. If it does not rotate smoothly, carry out the procedures from 1, and if it still does not rotate, overhaul the calendar assembly part.

- * Be careful not to pull out the crown to the second click position.
- * If you have pulled out the crown to the second click position, carry out the procedures from 1 again.
- * Be careful not to damage the crown.

- * If carrying out this check continuously, carry out re-checks at an interval of one minute or longer. Note that this is structured not to be electrically checked continuously.

▪ **Inspection method of perpetual calendar**

1. With the back case temporarily closed, recharge the watch until the amount of stored electrical energy in the rechargeable battery reaches above 1.3v.
2. Pull out the crown from the "0" position to the first click position, and leave it as it is for two seconds or longer.
Then, "pull the crown out and push it back in the order of the "0" position, first click position, "0" position, first click position and "0" position, and return it to the normal position." Carry out this operation within one second.
* **Setting the date to December 30th and carrying out this operation allows for a check of the year, month and date change.**
3. Check that the calendar automatically advances by "four days."
* If carrying out this check continuously, carry out re-checks at an interval of one minute or longer. Note that this is structured not to be electrically checked continuously.
4. Pull out the crown to the first click position and set the date to a non-existing date.
* February 30th, and 31st day of a shorter month
5. Push the crown back in to check that the date automatically changes to the "First day" of the next month.
6. If it does not automatically advance, carry out the procedures from 1, and if it still does not operate, overhaul the calendar assembly part.

(Note)

- Be careful not to pull the crown out to the second click position. If you have pulled out the crown to the second click position, again carry out the procedures from 1.
- Be careful not to damage the crown.

IV. TROUBLE SHOOTING GUIDE

- The following are the tips on repairing Cal. 7D48A, which you will find helpful in working on the watch.

1. Summary of important functions characteristic of Cal. 7D48A

- 1) The power save function is activated after the watch is left untouched for approximately 24 hours.
- 2) The manual power save function is activated by pulling out the crown to the first click and pushing it in to the normal position within one second.
- 3) While the second hand is moving at two-second intervals, the power save function cannot be activated either automatically or manually.
- 4) If the crown is pulled out to the second click while the power save function is in operation, the time computed by the built-in IC will be canceled, thus disabling the time relay function.
- 5) The accuracy of the time computed by the built-in IC while the power save function is in operation is equivalent to that of conventional quartz watches. If the power save function has been active for a long term before the time relay function is activated, the time indicated by the hands may include a certain amount of time loss or gain that has accumulated during that time.
- 6) If the power reserve is depleted while the power save function is in operation, the time relay function may not be activated by swinging the watch. Instead, the second hand starts moving at two-second intervals.



Problems, causes and methods of repair

Problems	Possible causes	Methods of repair and checking
The quickness of the hand movement after the activation of the time relay function has reduced a little.	1) The coil for detecting generation of the hour and minute coil block is broken.	1) Check the resistance of the coil for detecting generation. Replace the hour and minute coil block if the coil is broken.
The oscillating weight rotates at an abnormally high rate, and no charging is made.	1) The coil of the generating coil block is broken. 2) The pivot of the generating rotor is broken. (The pinion of the generating rotor and the gear of the intermediate wheel for generating rotor are out of mesh.)	1) Check the resistance of the generating coil block. Replace the generating coil block if the coil is broken. 2) Remove the broken piece of the generating rotor, and replace and lubricate the generating rotor. (Overhaul and clean if necessary.)
The oscillating weight will not rotate.	1) The gear of the oscillating weight and the pinion of the intermediate wheel for generating rotor are out of mesh. 2) The pivot of the generating rotor is broken. (The pinion of the generating rotor and the gear of the intermediate wheel for generating rotor engage with each other.)	1) If the gear of the oscillating weight and the pinion of the intermediate wheel for generating rotor are intact, reassemble them to the movement. 2) Remove the broken piece of the generating rotor, and replace and lubricate the generating rotor. (Overhaul and clean if necessary.)
The current consumption for the whole movement exceeds the standard value.	1) When the measurement is made, the IC is still in the quick start mode. (When the current consumption measures about 200 μ A, it is likely that the IC is in the quick start mode.) 2) The load applied on the gear train, etc. has increased, and the driving pulse to compensate it has been generated.	1) After connecting the tester, move the oscillating weight more quickly for a longer period of time, and then, make the measurement again. 2) If the current consumption for the circuit block alone is within the standard value range, overhaul and clean the movement parts, and then, make the measurement again.
The current consumption for the circuit block alone exceeds the standard value.	1) The light from outside the movement is affecting the measurement. 2) When the measurement is made, the IC is still in the quick start mode. (When the current	1) Shut out the light, and make the measurement again. 2) Switch the IC to the normal mode, and make the measurement again.

	<p>consumption measures about 200 μ A, it is likely that the IC is in the quick start mode.)</p> <p>3) The IC is out of order.</p>	<p>3) Replace the circuit block.</p>
<p>Swinging the watch while the power save function is active will not activate the time relay function. (Swinging the watch starts the second hand moving at two-second intervals.)</p>	<p>The energy stored in the rechargeable battery has been depleted while the power save function is in operation.</p>	<p>Swing the watch until the second hand moves at one-second intervals, and activate the power save function manually to check if the time relay function can be activated.</p>
<p>Swinging the watch while the power save function is active will not activate the time relay function. (Swinging the watch will not start the second hand moving at all.)</p>	<p>There is electric leakage inside the hour and minute coil block.</p>	<p>Check for leakage of the hour and minute coil block. Replace the part if leakage is detected.</p>
<p>After the time relay function is activated, the hands do not make the quick movement smoothly, or the hands indicate a time that differs greatly from the correct time.</p>	<p>There is electric leakage inside the hour and minute coil block.</p>	<p>Check for leakage of the hour and minute coil block. Replace the part if leakage is detected.</p>

*For troubleshooting of defects that conventional quartz watches have in common, refer to the "TECHNICAL GUIDE, GENERAL INSTRUCTIONS".

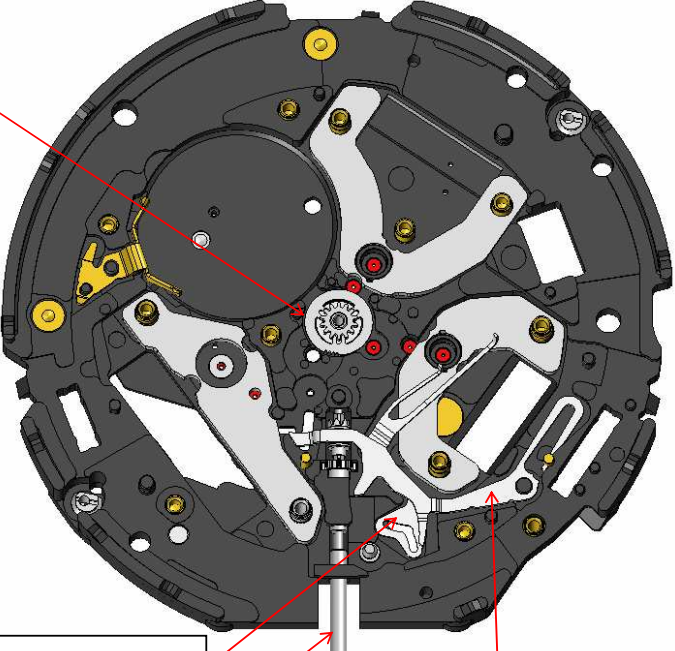
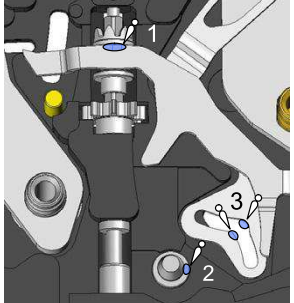
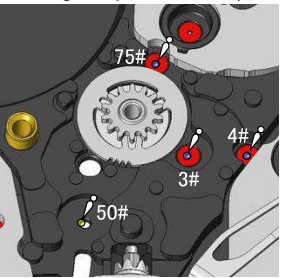
7D48 Technical Instruction

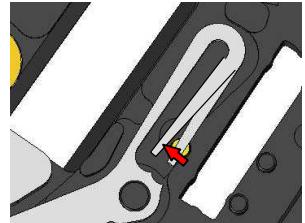
No.	PROCESS	ILLUSTRATIONS AND SPECIAL INSTRUCTIONS	
	Assembling the switching unit		
83	Set and lubricate the winding stem.		<p>Lubricating points of the switching unit-1</p> <ol style="list-style-type: none"> 1. Point of contact between the yoke and clutch wheel *Type of oil, oil quantity: A0-3III-1 (To prevent parts from wearing)  <ol style="list-style-type: none"> 2. Axes of the setting lever *Type of oil, oil quantity: A0-3II-1 (To prevent parts from wearing) 3. Guiding slit of the train wheel setting lever *Type of oil, oil quantity: A0-3I-2 (To prevent parts from wearing) 4. Lower pivots of the wheels (4#, 3#, 50#, 75#) *Type of oil, oil quantity: A0-3II-1 (To maintain good performance) 
82	Set and lubricate the center wheel & pinion.		
81	Set the train wheel setting lever.		
80	Set the yoke and hook the arm of it.		
	Lubricating points of the switching unit-1		
	-Stem of the setting lever		
	-Point of contact between the yoke and clutch wheel	<div style="border: 1px solid black; padding: 5px; display: inline-block;"> <p style="color: red; margin: 0;"><81> Set the train wheel setting lever.</p> </div>	
	-Lower pivots of the wheels (4#, 3#, 50#, 75#)	<div style="border: 1px solid black; padding: 5px; display: inline-block;"> <p style="color: red; margin: 0;"><83> Set and lubricate the winding stem.</p> <p>*Type of oil, oil quantity: A0-3 Lubricate the entire profile of the winding stem. (To prevent parts from wearing)</p> <p>*Securely install the winding stem, giving it gentle rotations so that the flat face of the winding stem will be engaged with both the clutch wheel and the 1st intermediate wheel for calendar corrector.</p> <div style="display: flex; align-items: center; margin-top: 10px;">  <div style="font-size: 2em;">}</div> <div style="margin-left: 5px;">Lubricating area</div> </div> </div>	
	- Guiding slit of the train wheel setting lever	<div style="border: 1px solid black; padding: 5px; display: inline-block;"> <p style="color: red; margin: 0;"><80> Set the yoke and hook the arm of it.</p> <p>Securely set the arm of the yoke inside the pin, taking care not to deform or damage the yoke.</p>  </div>	

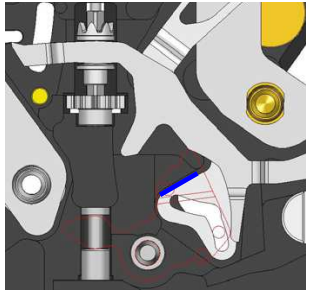
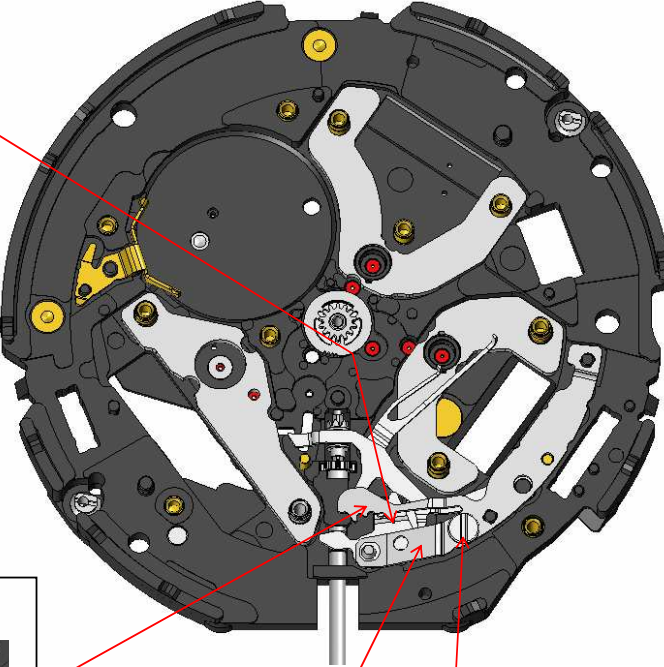
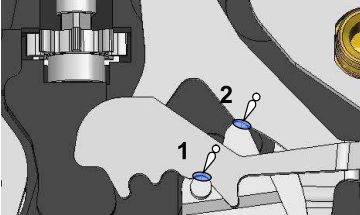
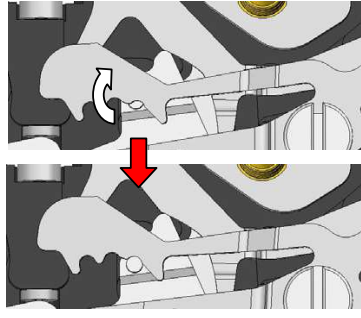
No.	PROSESS	ILLUSTRATIONS AND SPECIAL INSTRUCTIONS				
79	Set the setting lever. ↓	<p><79> Set the setting lever. *Before setting the setting lever, put the train wheel setting lever inside the frame of the main plate (as illustrated in blue). This will make the engagement between the pin of the setting lever and the guiding slit of the train wheel setting lever easier.</p> 		<p>Lubricating points of the switching unit-2</p>		
78	Set the setting lever spring. ↓				<ol style="list-style-type: none"> Point of engagement between the yoke and setting lever *Type of oil, oil quantity: A0-3II-1 (To prevent parts from wearing) Point of contact between the yoke and setting lever *Type of oil, oil quantity: A0-3II-1 (To prevent parts from wearing) 	
77	Tighten the setting lever spring. (33#) ↓					
Hook the arm of the setting lever. ↓					<p>Hook the arm of the setting lever.</p> 	<ol style="list-style-type: none"> Axis of the setting wheel *Type of oil, oil quantity: A0-3II-1 (To prevent parts from wearing)
Lubricating points of the switching unit-2						
<ul style="list-style-type: none"> -Point of engagement between the yoke and setting lever -Point of contact between the yoke and setting lever -Axis of the setting wheel 		<p><78> Set the setting lever spring.</p>	<p><77> Tighten the setting lever spring.</p>			

7D48 Technical Instruction

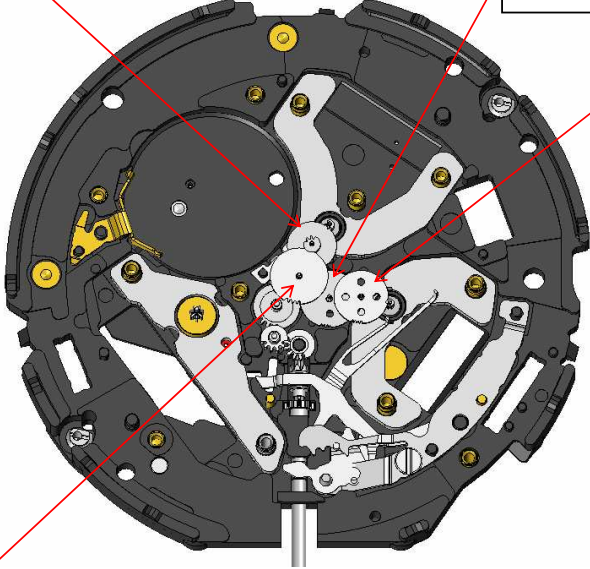
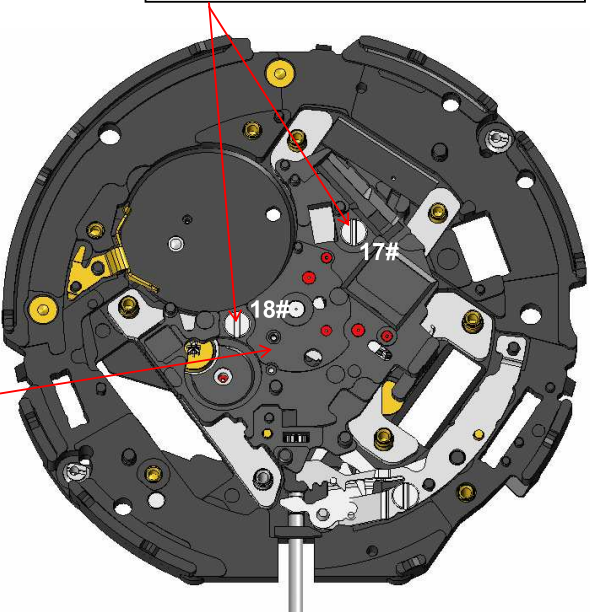

No.	PROSESS	ILLUSTRATIONS AND SPECIAL INSTRUCTIONS
69	Set the 3rd wheel & pinion.	<div data-bbox="510 316 1025 375" style="border: 1px solid black; padding: 5px;"> <p><67> Set the intermediate second wheel.</p> </div> <div data-bbox="1153 308 1731 403" style="border: 1px solid black; padding: 5px;"> <p><69> Set the 3rd wheel & pinion. * The 3rd wheel & pinion has three holes for distinction from the 5J2-series counterpart.</p> </div>
	↓	
68	Set the 4th wheel & pinion.	<div data-bbox="1272 430 1890 539" style="border: 1px solid black; padding: 5px;"> <p><68> Set the 4th wheel & pinion. *The 4th wheel & pinion has four holes for distinction from the 5J2- series counterpart.</p> </div>
	↓	
67	Set the intermediate second wheel.	<div data-bbox="656 391 1243 962" style="text-align: center;">  </div>
	↓	
66	Lubricate the second wheel & pinion.	<div data-bbox="1574 614 2011 686" style="border: 1px solid black; padding: 5px;"> <p><64> Tighten the train wheel bridge screw.</p> </div>
	↓	
65	Set the train wheel bridge and check the pivot hole.	<div data-bbox="1429 686 2016 1300" style="text-align: center;">  </div>
	↓	
64	Tighten the train wheel bridge screw.	<div data-bbox="1008 1061 1384 1133" style="border: 1px solid black; padding: 5px;"> <p><65> Set the train wheel bridge and check the pivot hole.</p> </div>

<66> Lubricate the second wheel & pinion.
 *Lubricating points: convex part
 (Refer to the illustration below.)
 *Type of oil, oil quantity: A0-3II-1
 (To prevent parts from wearing)

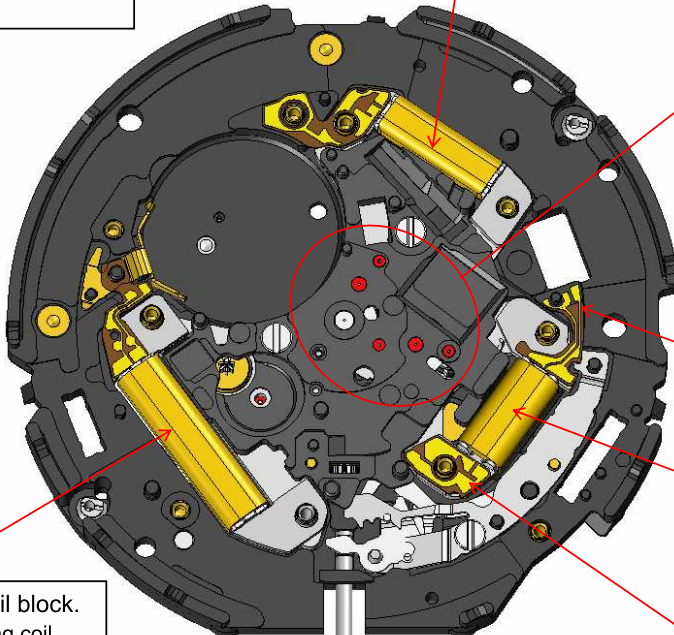

Lubricate with an appropriate amount of oil, as excessive lubrication may cause the second hand to wiggle while the watch resumes from power save mode.

7D48 Technical Instruction

No.	PROSESS	ILLUSTRATIONS AND SPECIAL INSTRUCTIONS
	Lubricate the upper pivots of the wheels. (5#, 76#, 4#, 3#, 74#, 75#, Tips of the teeth of the pinion of generating rotor 66#)	
63	Set the hour and minute coil block.	
62	Set the second coil block.	
61	Set the generating coil block.	
	Check each coil block resistance.	
		<div style="border: 1px solid black; padding: 5px; margin-bottom: 10px;"> <p><62> Set the second coil block. *When mounting the second coil block, take care not to deform or deform the coil block core. (To prevent deterioration of the motor)</p> </div> <div style="border: 1px solid black; padding: 5px; margin-bottom: 10px;"> <p><61> Set the generating coil block. *When mounting the generating coil block, take care not to deform or deform the coil block core. (To prevent deterioration of the motor)</p> </div> <div style="border: 1px solid black; padding: 5px; margin-bottom: 10px;"> <p><63> Set the hour and minute coil block. *When mounting the hour and minute coil block, take care not to distort or deform the coil block core. (To prevent deterioration of the motor)</p> </div> <div style="border: 1px solid black; padding: 5px; margin-bottom: 10px;"> <p>Pattern for checking the coil for detection</p> </div> <div style="border: 1px solid black; padding: 5px;"> <p>Pattern for checking the coil for driving</p> </div>
		<div style="border: 1px solid black; padding: 5px;"> <p>Lubricate the upper pivots of the wheels. ◆ 5#, 76# *Type of oil, oil quantity: A0-2II-1 (To maintain good performance) ◆ 4#, 3#, 74#, 75# *Type of oil, oil quantity: A0-3II-1 (To maintain good performance) ◆ Tips of the teeth of the pinion of the generating rotor (66#) *Type of oil, oil quantity: A0-3II-2 (To prevent parts from wearing)</p>  </div>

7D48 Technical Instruction

No.	PROSESS	ILLUSTRATIONS AND SPECIAL INSTRUCTIONS
	Assembling the circuit	
60	Set the insulator for circuit block.	
	↓	<div data-bbox="504 287 1512 462" style="border: 1px solid black; padding: 5px;"> <p><59> Set the circuit block. *Firmly press down the points of engagement to securely set it in position.</p> <p>Positioning guide tubes : 121#, 124# (green-circled in the illustration.) Points of engagement : 109#, 124#, 125#, 126#, 142#, 143#, 144# (red-circled in the illustration)</p> </div>
	Check the current consumption for the circuit block.	
	↓	
59	Set the circuit block.	
	↓	
58	Set and lubricate the intermediate wheel for generating rotor.	<div data-bbox="1579 287 2049 526" style="border: 1px solid black; padding: 5px;"> <p><58> Set and lubricate the intermediate wheel for generating rotor. Position (1) shown in the illustration below *Type of oil, oil quantity: A0-3II-2 (To prevent parts from wearing) Position (2) shown in the illustration below *Type of oil, oil quantity: A0-3II-1 (To prevent parts from wearing)</p> <div data-bbox="1713 534 1915 742" style="text-align: center;"> </div> <p>*Distinction between the 7D-series intermediate wheel for generating rotor and the 5J-series counterpart At the position shown by the red arrow, the 7D-series intermediate wheel for generating rotor has a groove, while the 5J-series counterpart does not.</p> <div data-bbox="1680 965 1960 1204" style="text-align: center;"> </div> </div>
		<div data-bbox="817 478 1568 1197" style="text-align: center;"> </div>
		<div data-bbox="1366 1300 1825 1364" style="border: 1px solid black; padding: 5px; text-align: center;"> <p><60> Set the insulator for circuit block.</p> </div>

7D48 Technical Instruction

No.11

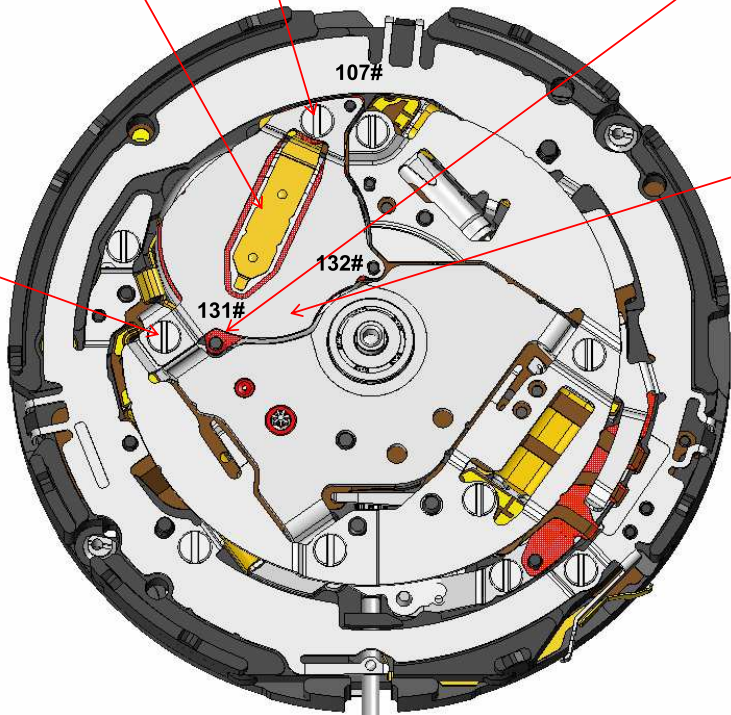
No.	PROSESS	ILLUSTRATIONS AND SPECIAL INSTRUCTIONS
	Assembling the power section	
7	Set the rechargeable battery unit. ↓	<div style="border: 1px solid black; padding: 5px; margin-bottom: 10px;"> <p><7> Set the rechargeable battery unit. *Stretching out the plus terminal to mount the rechargeable battery unit. *Take care not to deform the minus terminal when removing the rechargeable battery unit. (Remove the battery portion first.)</p> </div>  <div style="border: 1px solid black; padding: 5px; margin-bottom: 10px; position: absolute; top: 280px; right: 50px;"> <p><6> Set the insulator for rechargeable battery. *Firmly press down the points of engagement (132#, 107#) to securely set it in position. -Positioning guide tubes: 131#, 132# -Points of engagement: 132#, 107#</p> </div> <div style="border: 1px solid black; padding: 5px; margin-bottom: 10px; position: absolute; top: 430px; right: 50px;"> <p><5> Set the rechargeable battery clamp. *Firmly press down the point of engagement (132#) to securely set it in position. -Positioning guide tubes: 132#, 107# -Point of engagement: 132#</p> </div> <div style="border: 1px solid black; padding: 5px; position: absolute; top: 640px; right: 50px;"> <p><4> Tighten the rechargeable battery clamp screws. (102#, 35#)</p> </div>
6	Set the insulator for rechargeable battery. ↓	
5	Set the rechargeable battery clamp. ↓	
4	Tighten the rechargeable battery clamp screws. (102#, 35#)	

