

PARTS CATALOGUE/TECHNICAL GUIDE

Cal. 7D46A, 7D48A

【SPECIFICATIONS】

Item	Cal. No.	7D46A, 7D48A
Movement		
Movement size	Outside diameter	φ 32.0 mm
	Casing diameter	φ 30. 0 mm
	Height	6.1 mm
Time indication (Movement intervals)		3 hands (Hour and minute hands: 5-second interval movement, Second hand: 1-second interval movement), 24-hour hand Calendar Year indication: Indication disk for year (7D48A), Year indication hand (7D46A) Month indication: :Month indicator Date indication: Big calendar
Driving system		Step motor: 2 pieces · Piezoelectric motor (for calendar)
Additional mechanism		Automatic generating system Energy depletion forewarning function Overcharge prevention function Electronic circuit reset switch Train wheel setting device Instant setting device for date calendar Automatic power save function Time relay function Perpetual calendar (Year · Month · Date) up to February 28, 2100
Loss/gain		Monthly rate at normal temperature range: less than 15 seconds
Regulation system		Nil
Measuring gate by quartz tester		Use 10-second gate.
Power supply	Power generator	Automatic generating system
	Electricity storage Unit (E.S. Unit)	Titanium lithium ion rechargeable battery
Operating voltage range		0.45 v ~ 2.5 v
Continuous operating time		Operable time of time relay function: approximately 4 years if fully charged
Jewels		16 jewels

SEIKO WATCH CORPORATION

REMARKS ON REPAIRING CAL. 7D46A, 7D48A

Cal. 7D** is an Automatic Generating System analog quartz watch equipped with piezoelectric motor, featuring the perpetual calendar and automatic adjustment function. Although Cal.7D** features new functions, the experience of repairing the existing KINETIC series watches will be helpful.

In repairing Cal. 7D**, you are requested to have the full knowledge of its functions and strictly observe the repairing and checking instructions provided in this guide so that the watch will be repaired correctly.

FEATURES OF CAL. 7D46A, 7D48A

Cal. 7D** features the power save function that automatically stops the hands from moving if the watch is left untouched for a certain period of time. Even if the watch is in this state, the perpetual calendar continues to count the date until the stored electrical energy is depleted. When you decide to use it again, swinging the watch several times will activate the time relay function, which starts the hands moving quickly to indicate the correct time and resume the normal operation. Cal. 7D** is an innovative KINETIC model; it conserves the stored electrical energy by stopping the hands while it is not in use, and, at the same time, it completely eliminates the cumbersome time setting procedure when it is used again.

1. POWER SAVE FUNCTION

- While the watch is not in use, the hands stop automatically to minimize the electrical energy consumed. This is called "the power save function". Though the hands stop, the built-in IC continues to compute the time, keeping the watch ready for the next use.

<The automatic power save function>

If the watch is left untouched for approximately 24 hours, the power save function is automatically activated.

2. TIME RELAY FUNCTION

- While the power saving function is working, the built-in IC continues to compute the time though the hands stop. As the watch detects a certain amount of electricity generated by swinging it, the hands are automatically adjusted to the time retained inside the watch, resuming the normal operation. This is called the "time relay function". As it is activated, the hour and minute hands are adjusted first, then, followed by the second hand.
- By only swinging the watch for 2 to 3 seconds, the time relay function will be activated.

(Caution)

- ◆ It may take approximately up to 64 seconds (32 seconds on average) to activate the time relay function.
- ◆ The accuracy of the time computation by the built-in IC is equivalent to that of conventional quartz watches. Especially when the watch has been left untouched for a long time before the time relay function is activated, the time indicated by the hands may include a certain amount of time loss or gain within the range of the accuracy of the watch (± 15 seconds per month) that has accumulated during that time.

3. CONTINUOUS OPERATING TIME

The continuous operating time varies depending on the stored electrical energy inside the watch. In the case that the fully charged watch enters the power save mode,

the time relay function of the watch remains operable for approximately four years.

(Caution)

If the stored electrical energy is completely depleted while the watch is in the power save mode, swinging the watch may not activate the time relay function. Instead, the second hand starts moving at two-second intervals.

4. PERPETUAL CALENDAR

The perpetual calendar automatically adjusts the date up to February 28, 2100. Even if the watch is in the power save mode, the calendar continues to function as normal.

(Caution)

- ◆ The date changes between 23:30 and 0:30.
- ◆ Normally it takes approximately 2 seconds for the watch to change the date. However it may take up to 2 minutes especially during the wintertime or when the stored electrical energy is being depleted.
- ◆ Even though the watch is reactivated after the stored electrical energy has become extremely low, the calendar can be easily adjusted manually.
- ◆ When the watch is in power save mode, and the date does not change correctly (or shows the wrong date), the electrical power stored in the rechargeable battery is being depleted. Before starting to wear the watch, recharge the watch until the second hand no longer moves at two-second intervals and then reset the time and calendar.

5. TIME AND CALENDAR SETTING

It is recommended that you adjust the time and/or calendar during the time between 1:00 and 23:00.

If you adjust the time and/or calendar around 0:00, the date may become incorrect, but this is not a malfunction.

When the watch moves at two-second intervals, the date stops changing.

When the watch no longer moves at two-second intervals after it is recharged, reset the calendar.

When the date is set to a non-existing date, such as February 30, the calendar automatically correct the date. (When the date is set to February 30, the calendar automatically shows March 1).

When the stored electrical energy is completely depleted, and the watch is stopped, recharge the watch until it no longer moves at 2-second intervals and reset the time and calendar.

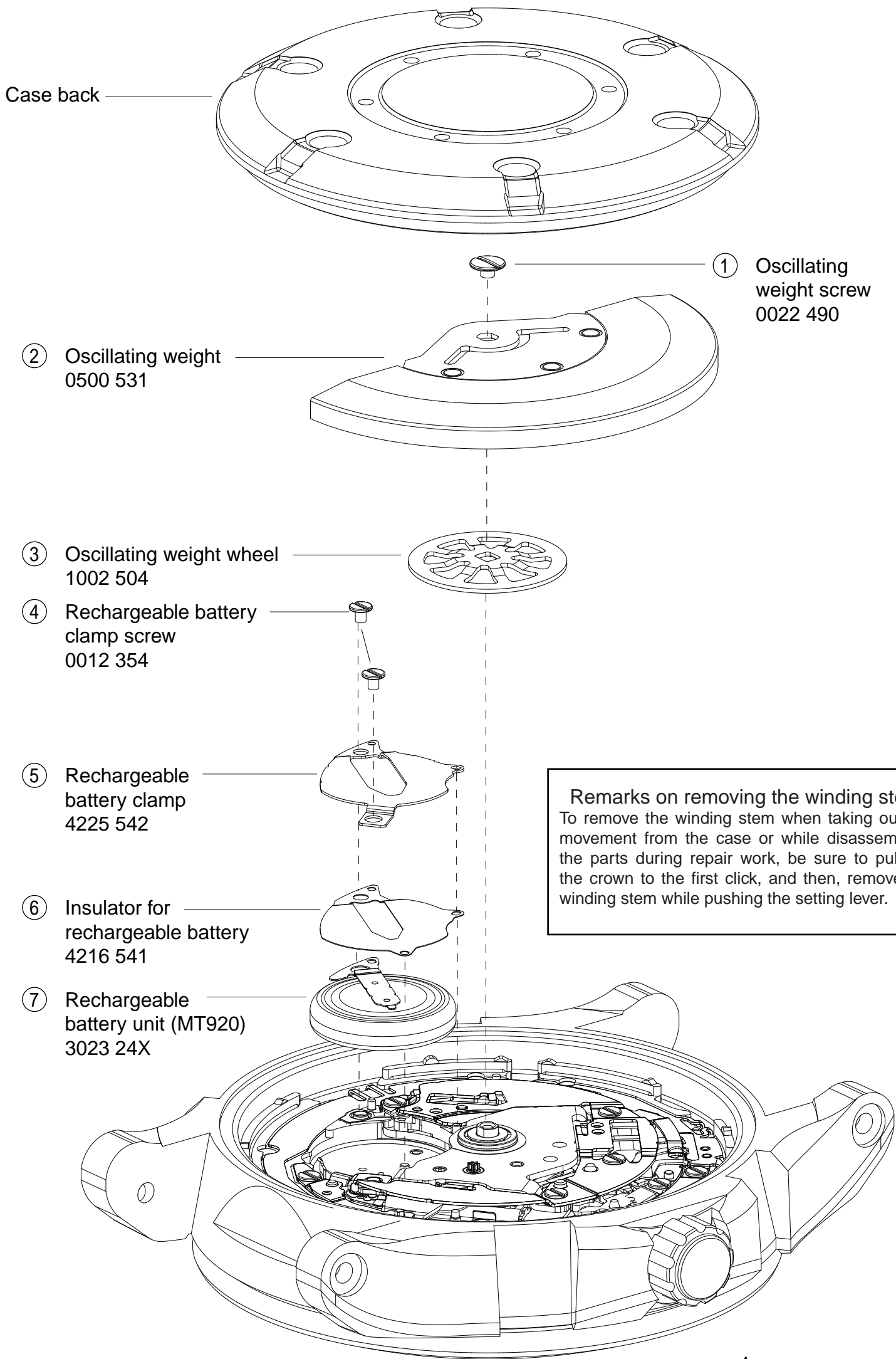

① Oscillating weight screw
0022 490

② Oscillating weight
0500 531

③ Oscillating weight wheel
1002 504

④ Rechargeable battery clamp screw
0012 354

⑤ Rechargeable battery clamp
4225 542

⑥ Insulator for rechargeable battery
4216 541

⑦ Rechargeable battery unit (MT920)
3023 24X

Remarks on removing the winding stem
To remove the winding stem when taking out the movement from the case or while disassembling the parts during repair work, be sure to pull out the crown to the first click, and then, remove the winding stem while pushing the setting lever.

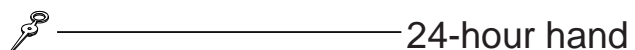
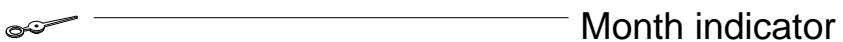
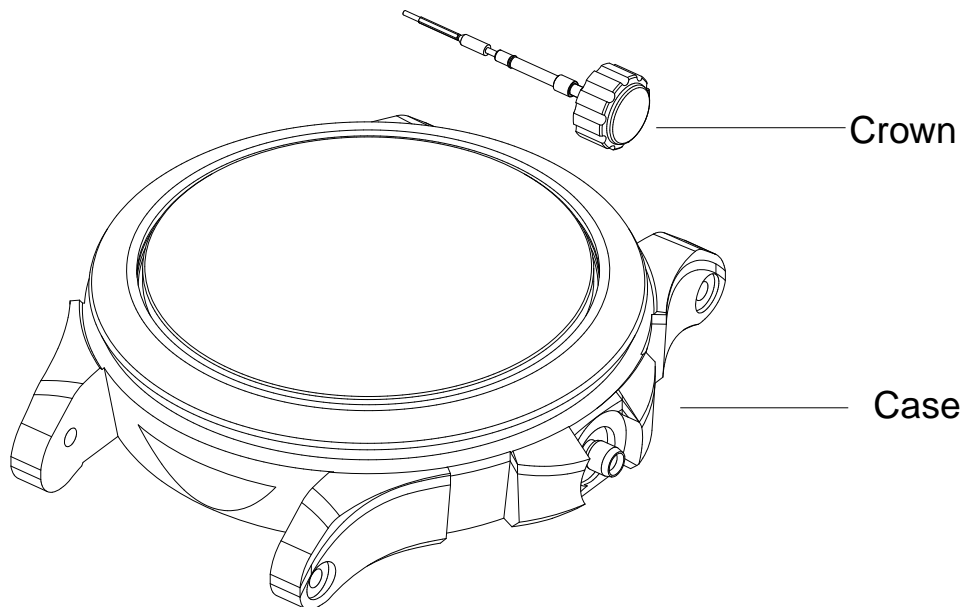

Year indicator hand
for cal.7D46A



This diagram shows a small, hook-shaped metal component, likely used for a year indicator. A line connects it to the text 'Year indicator hand for cal.7D46A'.

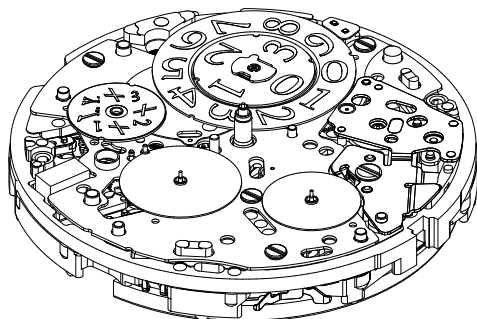
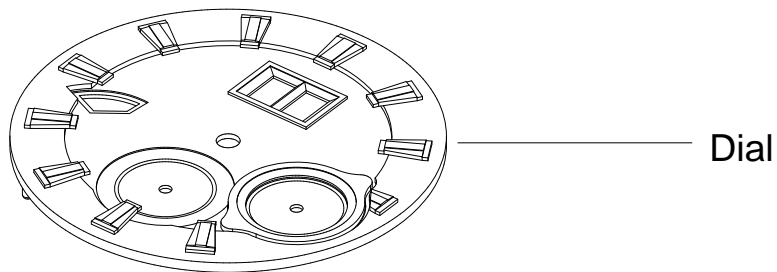

⑧ Indication disk
for year
1023 560 (for Cal.7D48A)

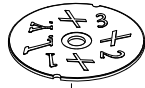

⑨ Date dial holder
for trans wheel
for units digit
0839 506



⑩ Date dial
for ten's digit
(0878 A84)

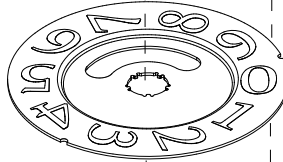

⑪ Date dial
for units digit
(0878 A85)



⑫ Jumper
for units digit
1024 500



⑬ Jumper for year
1024 503



※1.Positioning pin for spring
for intermediate wheel
for month indicator
To be removed while assembling



※1.Supporting pin for alignment
To be removed while assembling

2.This is the repairing tool.
(7D48A-JP)
Please look at the Watch
Repairing Tool Catalogue.

2.This is the repairing tool.
(7D48A-JP)

Please look at the Watch
Repairing Tool Catalogue.



⑭ Train wheel bridge
for calendar screw
0012 354

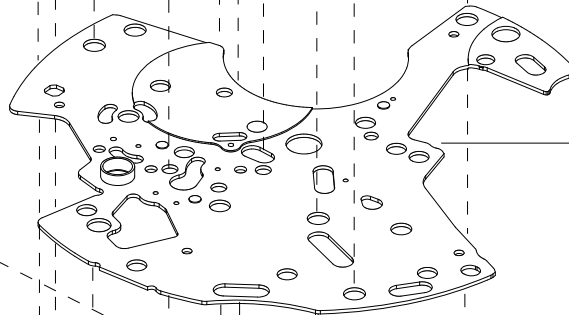

⑮ Train wheel bridge
for calendar
0125 508

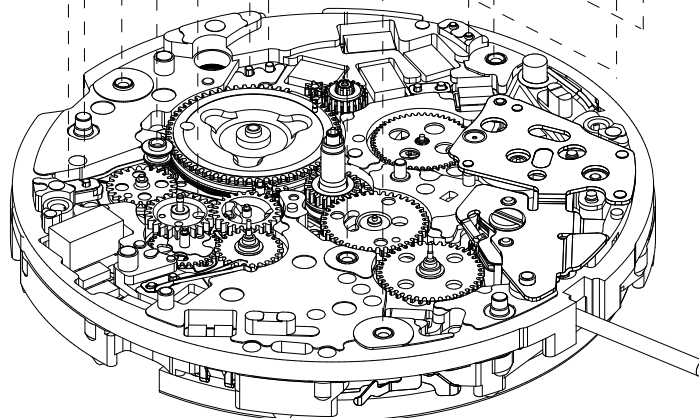

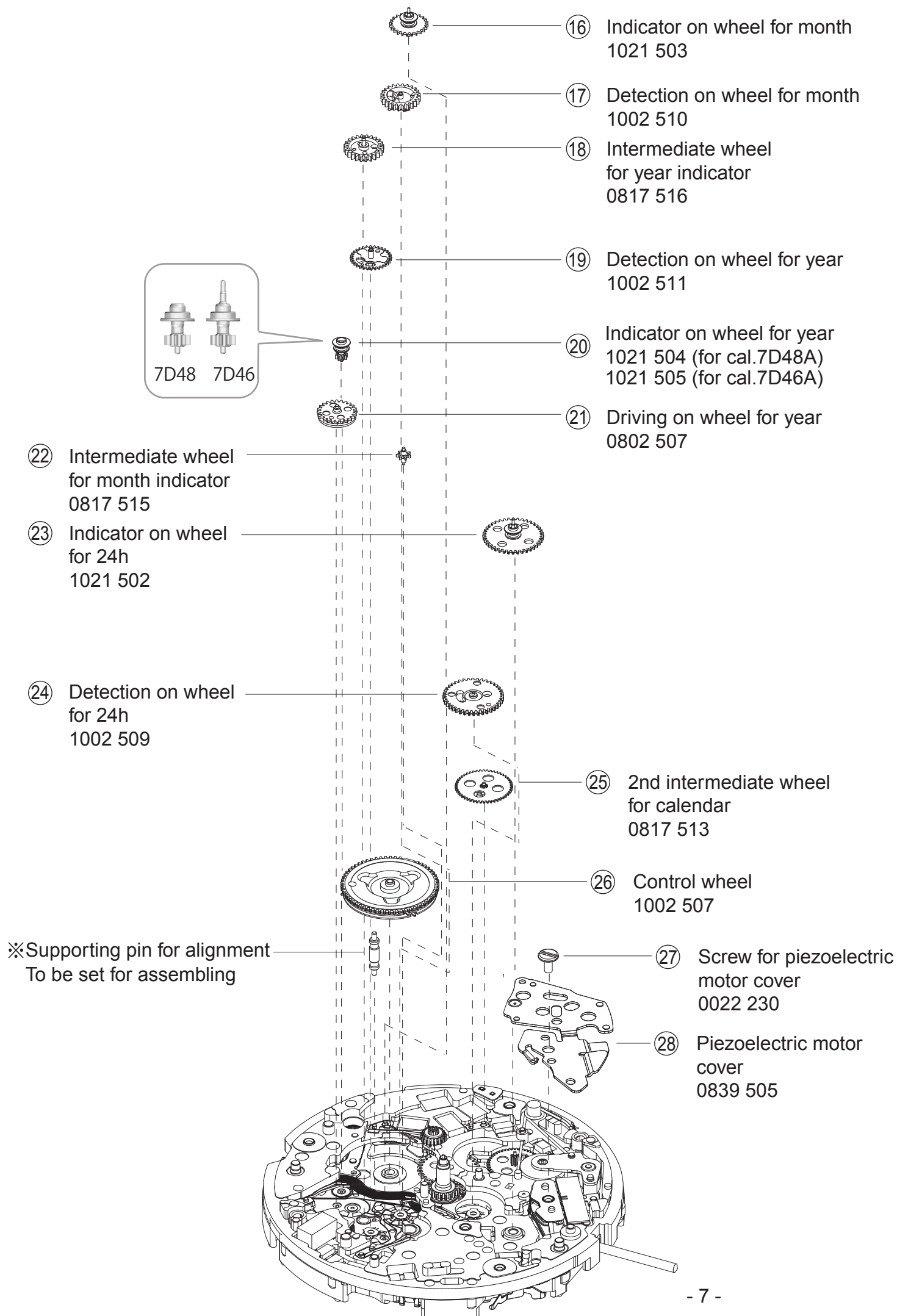

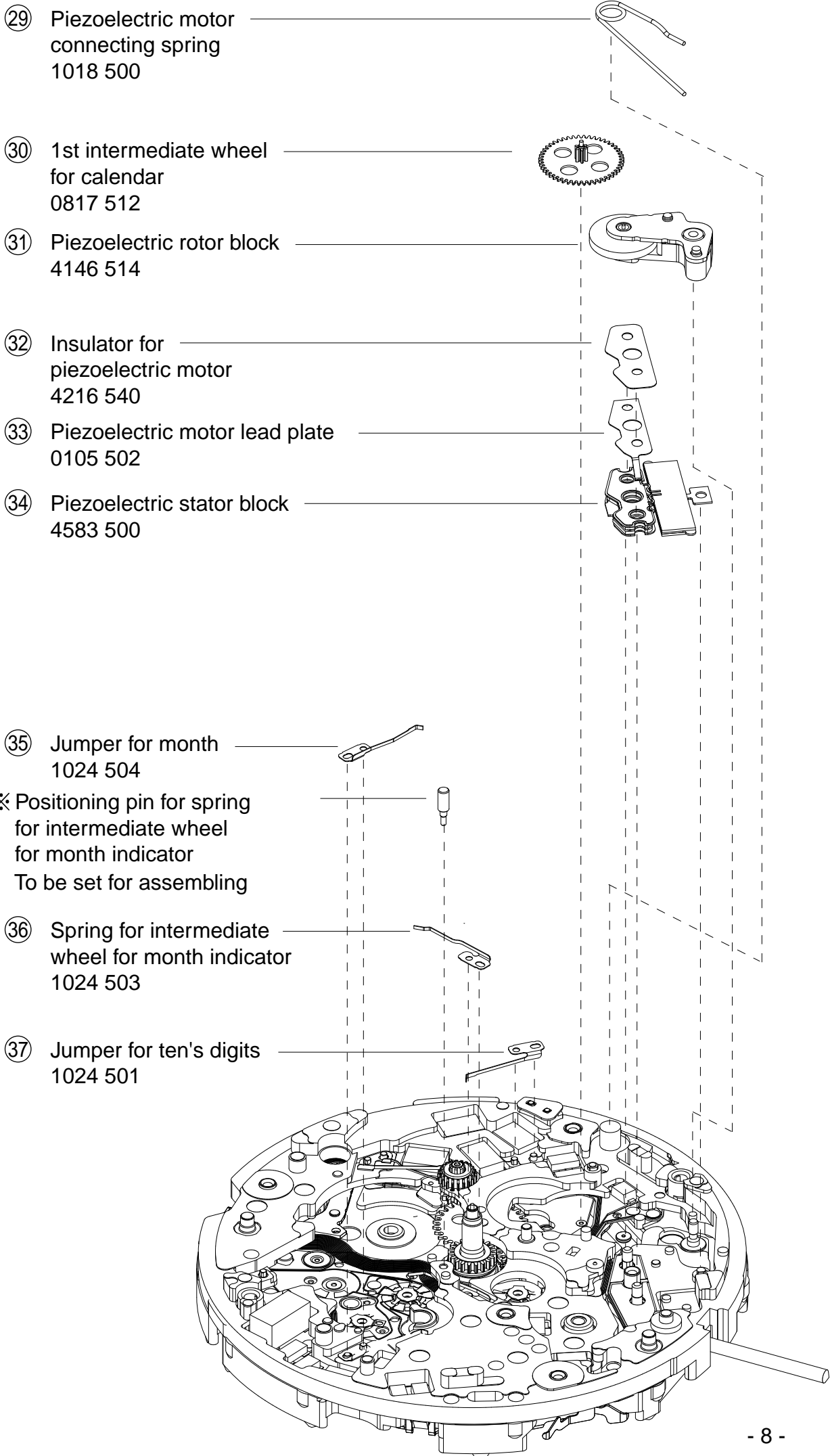

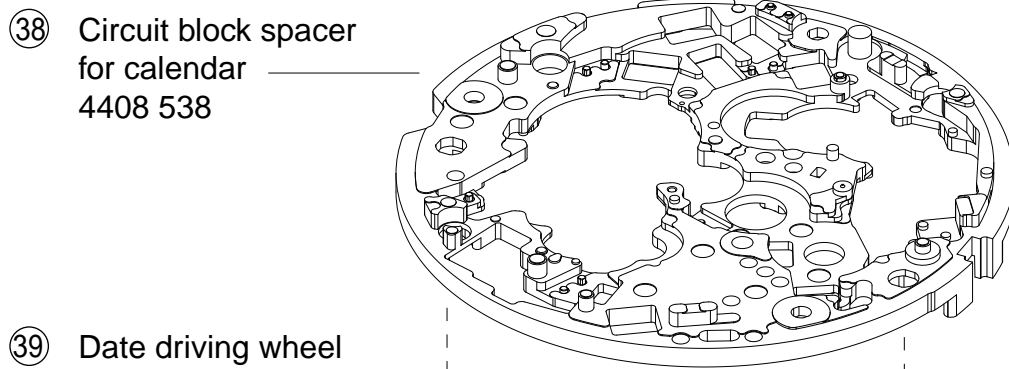

38 Circuit block spacer
for calendar
4408 538

39 Date driving wheel
for ten's digit
0802 506

40 Pinion
for ten's digit
1013 504

42 4th intermediate wheel
for calendar corrector
0962 502

44 Hour wheel
0271 564

45 Circuit block for calendar
4000 595

47 A connector
4313 581

49 Control jumper
1024 502

51 Contact point spring
4281 510

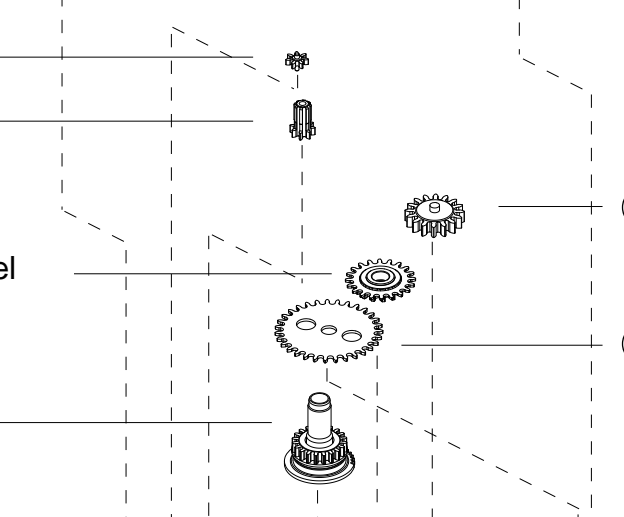

41 3rd intermediate wheel
for calendar corrector
0962 501

43 3rd intermediate wheel
for calendar
0817 514



46 B connector
4313 582

48 Ratchet lever
0981 500

50 2nd intermediate wheel
for calendar corrector
0962 559

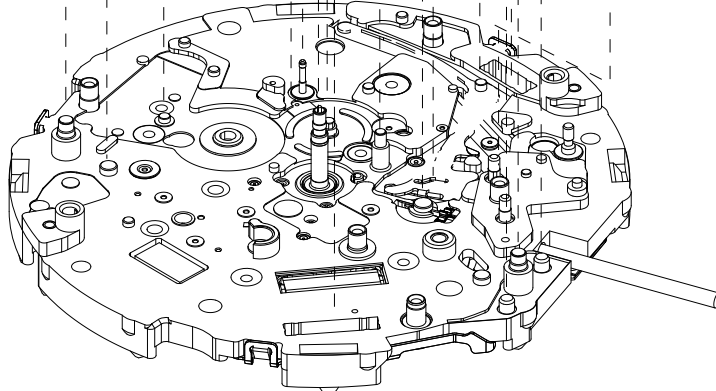
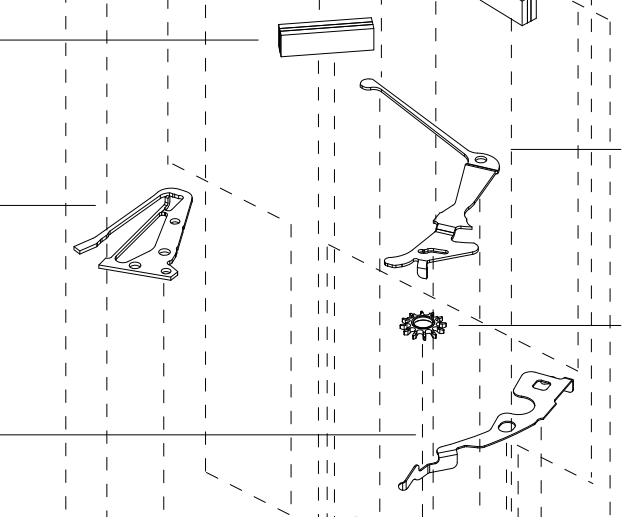

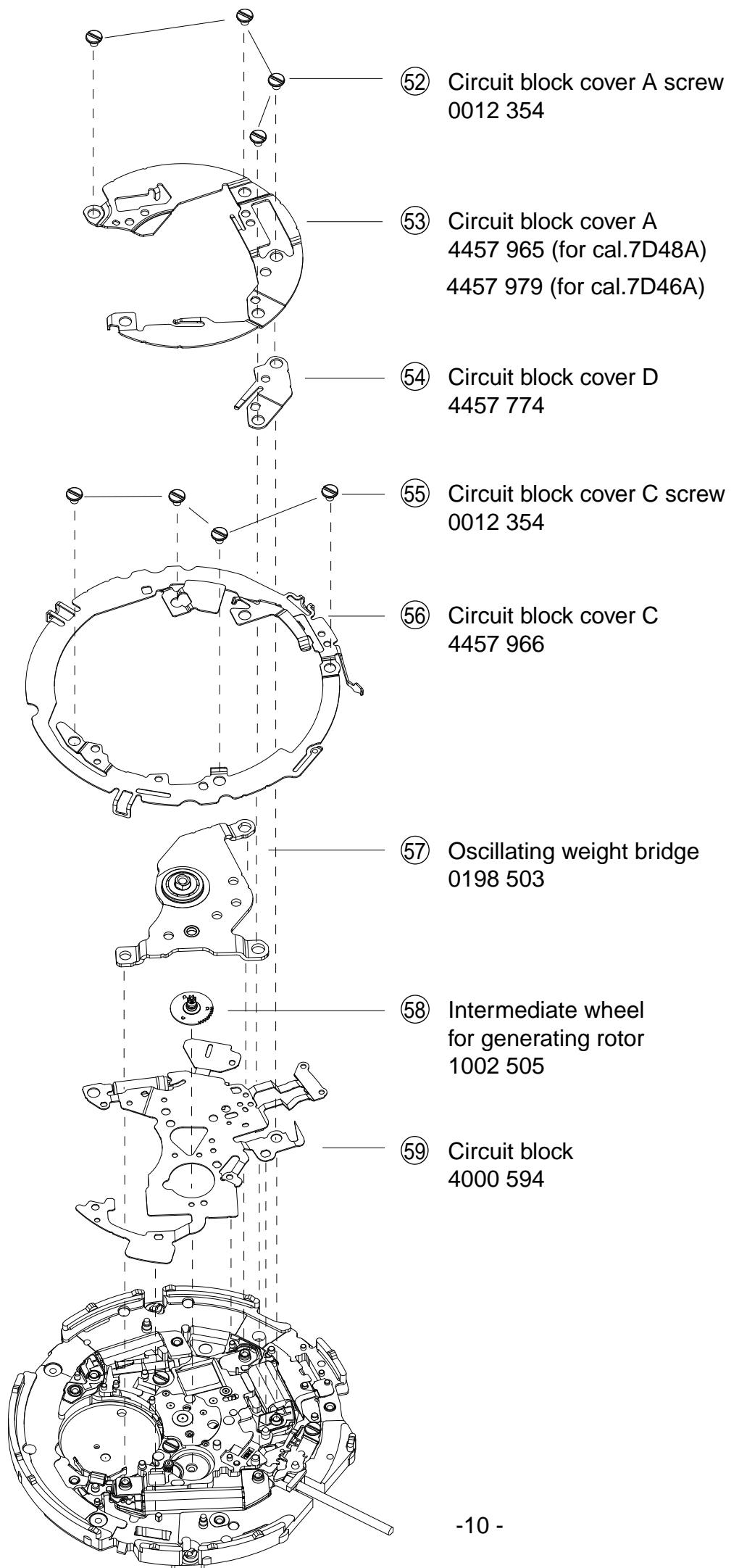

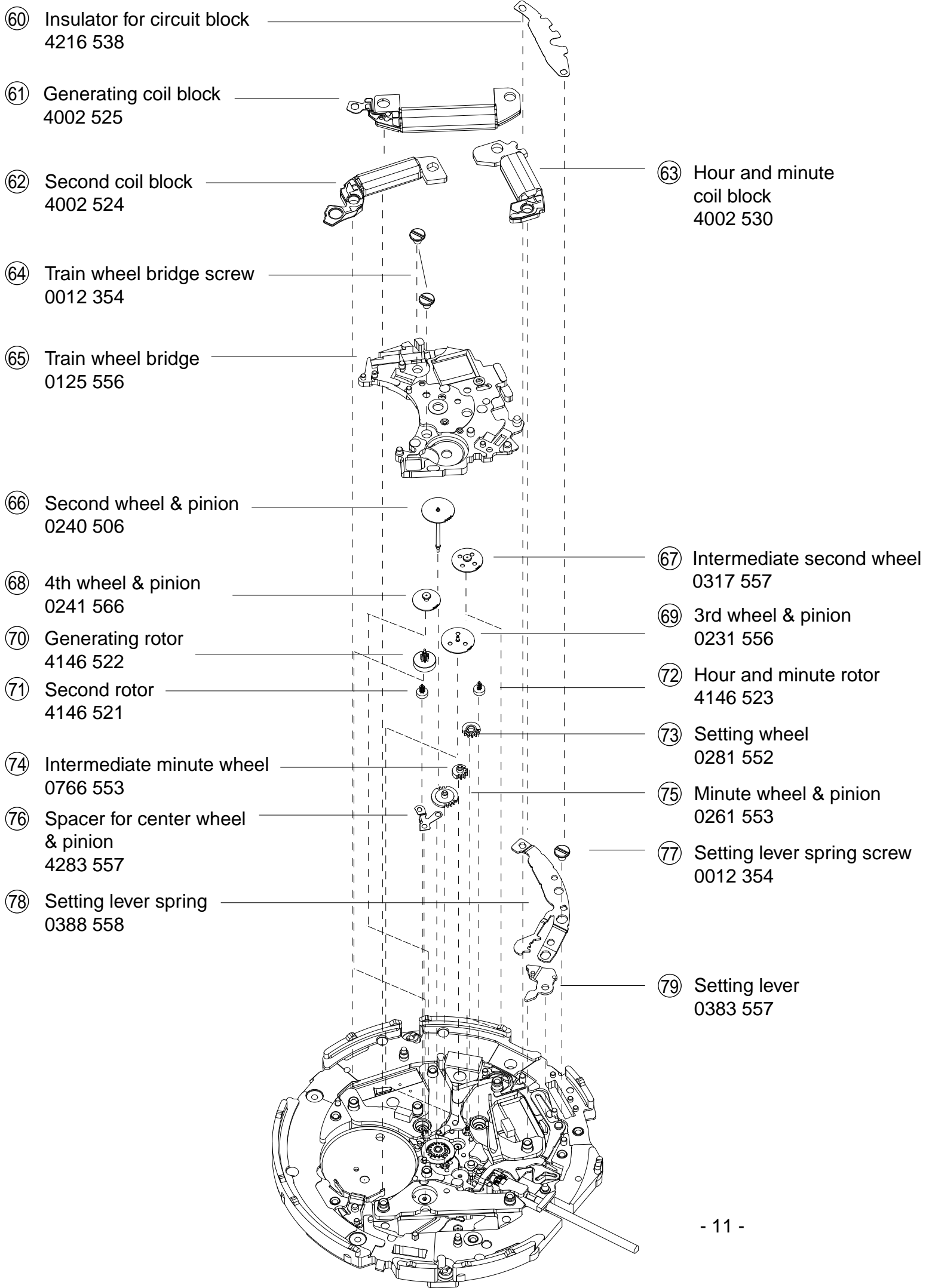

80 Yoke
0384 557

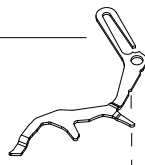

81 Train wheel setting lever
0391 557

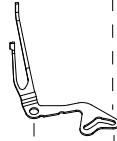

82 Center wheel
& pinion
0221 712



84 Clutch wheel
0282 523

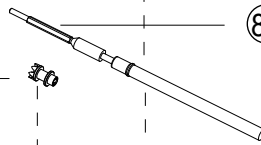

83 Winding stem
(0351 510)



85 1st intermediate wheel
for calendar corrector
0962 557

86 Rechargeable
battery connection(+)
4271 522



87 Generating stator
4239 527

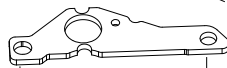

88 Second stator
4239 523

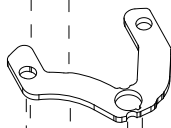

89 Hour and minute stator
4239 522

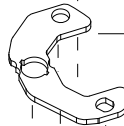

90 Lead pin for RZ1
0027 369



91 Main plate
0100 710

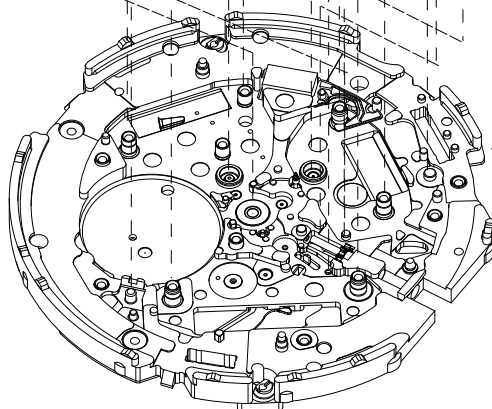

Remarks

<7D48A>

⑧ Indication disc for year ⑩ Date dial for ten's digit ⑪ Date dial for units digit

Date dial for unit digit	Date dial for ten's digit	Indication disc for year	Color of figure	Color of background	Font type
0878A85	0878A84	1023560	BLACK	WHITE	Italic
0878A91	0879A90	1023561	BLACK	WHITE	Gothic
0878B06	0878B05	1023563	WHITE	BLACK	Gothic

<7D46A>

⑩ Date dial for ten's digit ⑪ Date dial for units digit

Date dial for unit digit	Date dial for ten's digit	Color of figure	Color of background
0878B06	0878B05	WHITE	BLACK
0878A91	0878A90	BLACK	WHITE

⑧④ Winding Stem 0351510

The above parts are determined based on the case design.
Refer to Parts Catalogue Web site to choose a corresponding part.

The explanation here is only for the particular points of Cal. 7D48A.
 For the repairing, checking and measuring procedures, refer to the “TECHNICAL GUIDE, GENERAL INSTRUCTIONS”.

I. STRUCTURE OF THE CIRCUIT BLOCK

⑤9 Circuit block



④5 Circuit block for calendar



II. REMARKS ON DISASSEMBLING AND REASSEMBLING

1. About “exclusive jig pin” used for assembly

Cal. 7D** employs a new structure for the calendar unit; therefore, it is necessary to set each gearwheel correctly when assembling. Consequently, two kinds of “exclusive jig pins” are available in consideration of efficiency in assembly performance. Be sure to use these “exclusive jig pins” for assembly of the calendar unit.

* Be careful not to forget to remove and not to lose the “exclusive jig pin” when assembling is completed.

<How to use the exclusive jig pins>

◆ “Positioning pin for the spring for intermediate wheel for month indicator”

In assembly, set the “positioning pin for the spring for intermediate wheel for month indicator” after assembling the (38) jumper for ten’s digit, and remove it after assembling from the (37) spring for intermediate wheel for month indicator to the (15) train wheel bridge for calendar screws.

◆ “Supporting pin for alignment”

In assembly, set the “supporting pin for alignment” after assembling the (28) screw for the piezoelectric motor cover, and remove it after assembling from the (27) control wheel to the (15) train wheel bridge for calendar screws.

2. Precautions for jumpers on calendar unit when assembling and disassembling

Target parts:

- (35) Jumper for month, (36) Spring for intermediate wheel for month indicator
- (37) Jumper for ten’s digit, (12) Jumper for units digit, (13) Jumper for year

Precautions for disassembly and assembly

For disassembly: When individually disassembling the above parts, remove them with sufficient care since they are used at the points of engagement. Additionally, they can be disassembled even in a state attached to the circuit block spacer for calendar without individual disassembling.

For assembly: Check the points of engagement for rattle when assembling. If they rattle, replace the circuit block spacer for the calendar.

3. How to install the hands

Cal. 7D** features the perpetual calendar. Thus, the hands should be carefully mounted exactly as instructed below.

1. Pull out the winding stem to the first click position, and set the calendar to “the leap year, January 1”

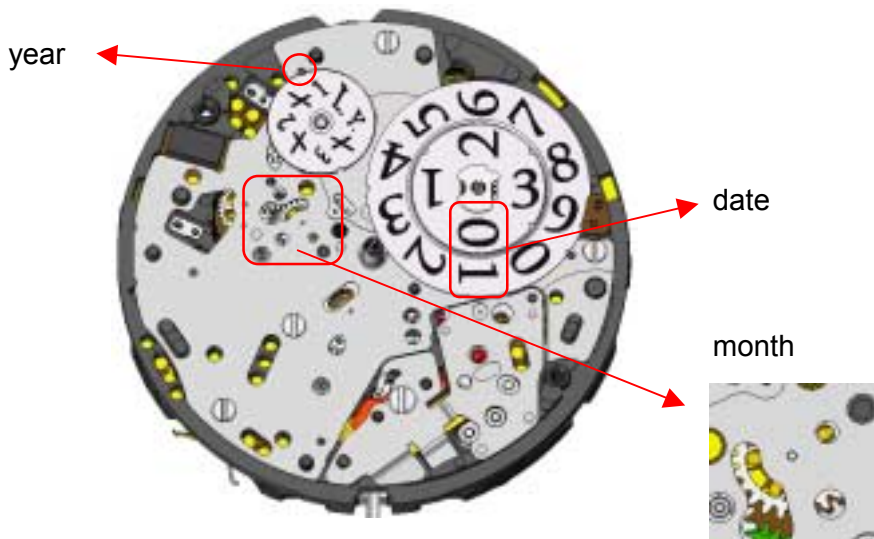

2. Pull out the winding stem to the second click position, and turn the crown to set the 24H contact point as illustrated below. (To correct the timing of date change)

*Connect the probes of testers to “A” and “B” portions. The 24H contact point will be adjusted, allowing for a check of date changing status.

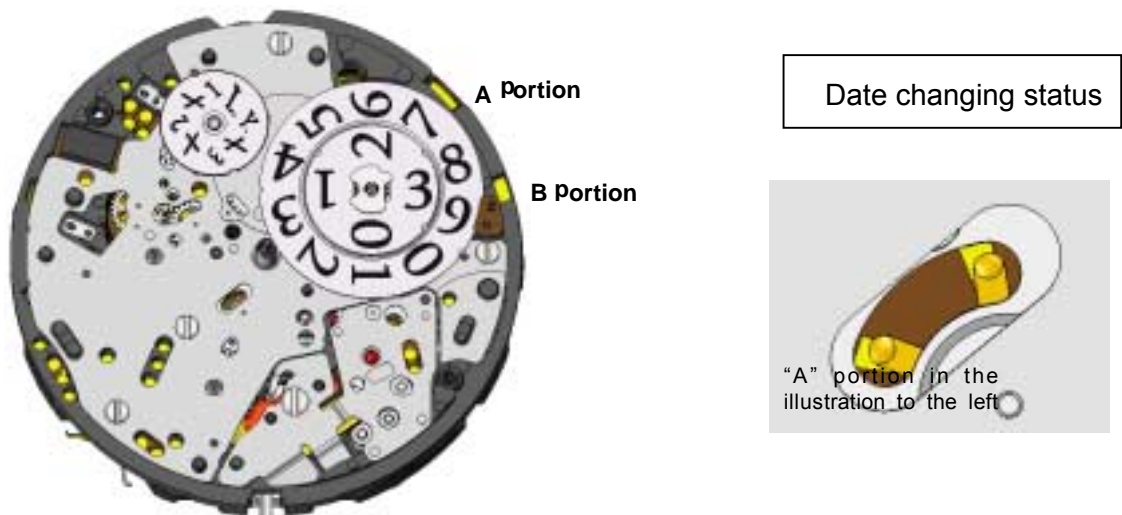

3. Keep the watch in this state when carrying out the installation of the hands in order of the 24-hour hand, month indicator, hour hand, minute hand and second hand.

* When removing the hands during repair work, ensure that the calendar is set to “the individual disassembling.” If the hands are removed with the calendar set to a date other than “the leap year, January 1”, the correct position of the year may be lost.

III. VALUE CHECKING AND ADJUSTMENT

● Coil block resistance

Second coil block:	2.00k	—	2.45k
Hour and minute coil block:			
Coil for driving hands:	1.00 k	—	1.25 k
Coil for detecting rotation of the rotor:	270	—	330
Generating coil block:	360	—	420

Note:

Measure the coil block resistance after installing each coil block to the movement, checking that stable measurements are obtained.

*The motor driving the hour and minute hands uses a special driving system so that they move quickly to indicate the current time immediately after the time relay function is activated. The hour and minute coil block has two layers of coils, one for driving the hands and the other for detecting rotation of the rotor, and it is necessary to measure the resistance of each coil layer.

• The illustration below shows the patterns to which the probes of the tester should be applied to measure the resistance of the respective coils.

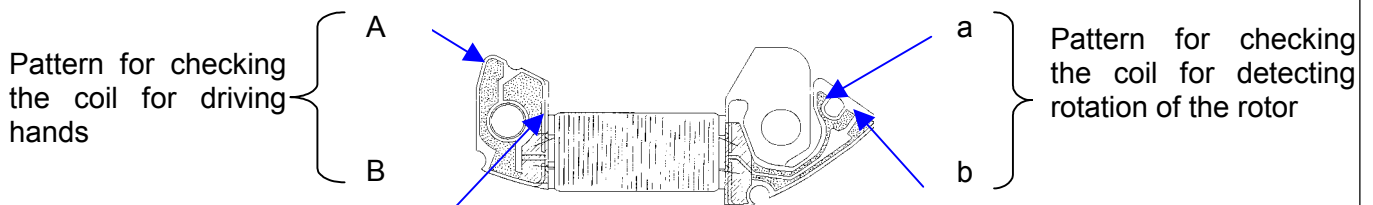

● Checking for leakage between coil for driving hands and coil for detecting rotation of the rotor

*If the hour and minute hands do not move properly when the time relay function is activated, that is, if they remain stopped or will not move smoothly, check for leakage between coil for driving hands and coil for detecting rotation of the rotor. This checking is required only if such a problem is found.

If leakage is detected, replace the hour and minute coil block with a new one.

● How to check the leakage

1. Make the tester ready for measuring the resistance.
2. Apply the probes of the tester to 1 "A" and "a", 2 "A" and "b", 3 "B" and "a", and 4 "B" and "b", respectively, to measure the resistance.
3. If the four measurements obtained are all infinitely great, that is, if the resistance is unable to be measured for all the four cases, there is no leakage between coil for driving hands and coil for detecting rotation of the rotor. As a guideline, there is leakage if measurements of less than 2 k are obtained.

Generating coil block resistance

340 - 440

Note: Measure the generating coil block resistance after installing it to the movement, checking that stable measurements are obtained.

● **Current consumption**

For the whole movement (while the hands are moving):

Less than $0.70 \mu A$ (with 1.55 V supplied from a battery)

For the circuit block alone:

Less than $0.40 \mu A$ (with 1.55 V supplied from a battery)

● **How to measure the current consumption for the whole movement (while the hands are moving)**

1. Disassemble unnecessary parts to make the movement ready for the measurement. Follow the disassembling procedure illustrated in this manual until you remove the rechargeable battery unit, and then, reassemble the oscillating weight. As a result, the rechargeable battery unit, insulator for rechargeable battery and rechargeable battery clamp are removed from the movement.
2. Apply the minus terminal to "a" portion in the illustration and plus terminal to the circuit block cover A, respectively.

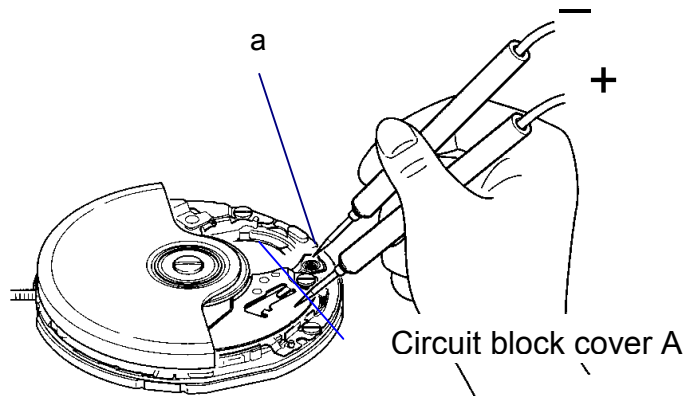

3. For a few seconds after the probes of the tester are applied to the movement, the IC is in the quick start mode, and current consumption cannot be measured properly. To switch the IC from the quick start to the normal hand movement mode, move the oscillating weight from side to side continuously for more than three seconds with the tester connected to the movement. (The IC will detect the electricity generation and will be switched to the normal hand movement mode.)

Note

When moving the oscillating weight from side to side, take care lest the minus terminal of the tester touches the oscillating weight.

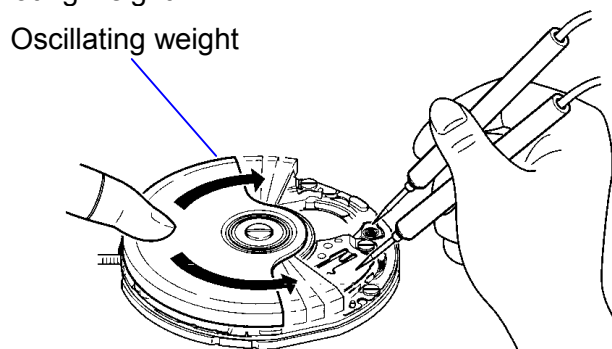

4. After checking that the IC has been switched to the normal hand movement mode and a stable measurement can be obtained, read the measurement. (If the measurement value remains high or unstable, repeat step "3" above.)

Notes:

* Light may increase the current consumption, resulting in an inaccurate measurement. If the current consumption exceeds the standard value, protect the movement from light with a black cloth or the like after following step "3" above, and make a measurement again.

* When the current consumption for the whole movement exceeds the standard value while the current consumption for the circuit block alone is within the standard value range, a driving pulse may be generated to compensate for the heavy load applied on the gear train, etc. In that case, overhaul and clean the movement parts, and then, measure the current consumption for the whole movement again.

● **How to measure the current consumption for the circuit block alone**

1. Connect the tester to the circuit block as shown in the illustration.

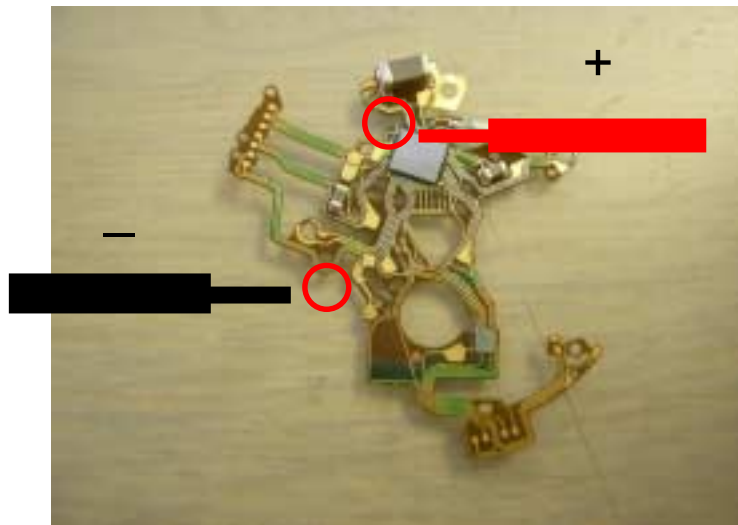

2. Checking that a stable measurement is obtained, read the current consumption. (If the measurement value remains high or unstable, repeat step “2” above.)

Notes:

* The current consumption measurement for the circuit block alone is particularly susceptible to light, and a value higher than the actual measurement may be obtained if the circuit block is exposed to light. Protect the circuit from light with a black cloth or the like after following step “2” above, and then, measure the current consumption.

* If the current consumption for the circuit block alone exceeds the standard value, the duration of the charge will be shorter than specified. In that case, replace the circuit block with a new one.

● **Checking the automatic generating system**

1. Apply the probes of the tester as shown in the illustration, and measure the voltage of the rechargeable battery. (The obtained voltage is called the “initial voltage”.)

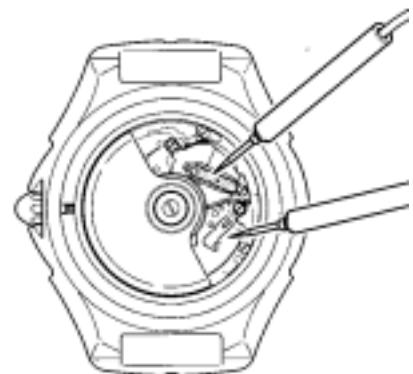

Notes:

- ◆ When applying the minus probe of the tester to the rechargeable battery, take care not to short-circuit the lead terminal (-) and the rechargeable battery clamp.
- ◆ If a short-circuit has occurred, leave the watch untouched for more than ten minutes, and measure the voltage again, checking that a stable measurement is obtained.

2. Close the case back tentatively, and swing the watch from side to side 200 times at a rate of 2 to 3 swings a second, making an arc of approximately 20 cm.



3. Within 3 minutes after swinging the watch, measure the voltage of the rechargeable battery in the same manner as in step “1” above.
4. Refer to the table below, and decide whether the automatic generating system is normal or defective.

[Initial voltage and guidelines of normal/defective decision]

Initial voltage	Guidelines of normal/defective decision
0.45 ~ 1.0 V	After charging, the voltage of rechargeable battery has increased 0.1 V or more from the initial voltage.
1.01 ~ 1.2V	After charging, the voltage of rechargeable battery has increased 0.05 V or more from the initial voltage.

- * The guidelines specified in the above table apply only when the initial voltage is within the range between 0.45 V and 1.2 V.
- * The amount of electricity generated by swinging the watch varies depending on the manner in which you swing it, such as the rate of swinging and the size of the swinging arc. Please note, therefore, that checking through the procedure above provides only a guideline for normal/defective decision.

<For your information>

1. Number of swings and power reserve
 - ◆ When the power reserve inn the rechargeable battery is depleted and the watch stops completely, swinging it approximately 500 times at a rate of 2 to 3 times a second will start the second hand moving at normal one-second intervals in stead of two-second intervals. If the second hand still moves at two-second intervals after 500 swings, swing the watch further until it moves at one-second intervals.
 - ◆ While the second hand is moving at one-second intervals, swing the watch further until it moves at one-second intervals.
2. The number of days over which the watch is worn and power reserve
 - ◆ Wearing the watch continuously for 12 hours will accumulate approximately one and a half additional days of power reserve.
(Example)
If you wear the watch every day for 12 hours over a period of a week, approximately 10 days of power reserve will be secured in the rechargeable battery. While the power saving function is in operation and the hands are stopped, this amount of power reserve will keep the watch operating for approximately 2 months.

Inspection of perpetual calendar and PTP operation in move state

Cal. 7D48A is equipped with a perpetual calendar which automatically advances the calendar up to February 28, 2100.

Here, an inspection is carried out if the “perpetual calendar” operates normally.

Note:

This inspection cannot be made when the watch is stopped. If the watch to be inspected has stopped, start the inspection after the second hand starts moving at 1-second interval by manually charging it and the amount of stored electrical energy reaches above 1.3v.

▪ Inspection method of PTP operation in move state

1. Recharge the rechargeable battery until the amount of stored electrical energy reaches above 1.3v.
2. After tightening the (28) screw for the piezoelectric motor cover, pull out the crown from the “0” position to the first click position and leave it as it is for two seconds or longer. Then, “Pull the crown out and push it back in the order of the “0” position, first click position, “0” position, first click position and “0” position, and return it to the normal position.” Carry out this operation within one second.
3. Check that the (32) piezoelectric rotor rotates smoothly. (Normal operation)
If it rotates smoothly, PTP operation is normal.
4. If it does not rotate smoothly, carry out the procedures from 1, and if it still does not rotate, overhaul the calendar assembly part.

- * Be careful not to pull out the crown to the second click position.
 - * If you have pulled out the crown to the second click position, carry out the procedures from 1 again.
 - * Be careful not to damage the crown.
- * If carrying out this check continuously, carry out re-checks at an interval of one minute or longer. Note that this is structured not to be electrically checked continuously.

▪ Inspection method of perpetual calendar

1. With the back case temporarily closed, recharge the watch until the amount of stored electrical energy in the rechargeable battery reaches above 1.3v.
2. Pull out the crown from the “0” position to the first click position, and leave it as it is for two seconds or longer.
Then, “pull the crown out and push it back in the order of the “0” position, first click position, “0” position, first click position and “0” position, and return it to the normal position.” Carry out this operation within one second.
* **Setting the date to December 30th and carrying out this operation allows for a check of the year, month and date change.**
3. Check that the calendar automatically advances by “four days.”
* If carrying out this check continuously, carry out re-checks at an interval of one minute or longer. Note that this is structured not to be electrically checked continuously.
4. Pull out the crown to the first click position and set the date to a non-existing date.
* February 30th, and 31st day of a shorter month
5. Push the crown back in to check that the date automatically changes to the “First day” of the next month.
6. If it does not automatically advance, carry out the procedures from 1, and if it still does not operate, overhaul the calendar assembly part.

(Note)

- Be careful not to pull the crown out to the second click position. If you have pulled out the crown to the second click position, again carry out the procedures from 1.
- Be careful not to damage the crown.

IV. TROUBLE SHOOTING GUIDE

- The following are the tips on repairing Cal. 7D46A, 7D48A, which you will find helpful in working on the watch.

1. Summary of important functions characteristic of Cal. 7D46A, 7D48A

- 1) The power save function is activated after the watch is left untouched for approximately 24 hours.
- 2) The manual power save function is activated by pulling out the crown to the first click and pushing it in to the normal position within one second.
- 3) While the second hand is moving at two-second intervals, the power save function cannot be activated either automatically or manually.
- 4) If the crown is pulled out to the second click while the power save function is in operation, the time computed by the built-in IC will be canceled, thus disabling the time relay function.
- 5) The accuracy of the time computed by the built-in IC while the power save function is in operation is equivalent to that of conventional quartz watches. If the power save function has been active for a long term before the time relay function is activated, the time indicated by the hands may include a certain amount of time loss or gain that has accumulated during that time.
- 6) If the power reserve is depleted while the power save function is in operation, the time relay function may not be activated by swinging the watch. Instead, the second hand starts moving at two-second intervals.

Problems, causes and methods of repair

Problems	Possible causes	Methods of repair and checking
The quickness of the hand movement after the activation of the time relay function has reduced a little.	1) The coil for detecting generation of the hour and minute coil block is broken.	1) Check the resistance of the coil for detecting generation. Replace the hour and minute coil block if the coil is broken.
The oscillating weight rotates at an abnormally high rate, and no charging is made.	1) The coil of the generating coil block is broken. 2) The pivot of the generating rotor is broken. (The pinion of the generating rotor and the gear of the intermediate wheel for generating rotor are out of mesh.)	1) Check the resistance of the generating coil block. Replace the generating coil block if the coil is broken. 2) Remove the broken piece of the generating rotor, and replace and lubricate the generating rotor. (Overhaul and clean if necessary.)
The oscillating weight will not rotate.	1) The gear of the oscillating weight and the pinion of the intermediate wheel for generating rotor are out of mesh. 2) The pivot of the generating rotor is broken. (The pinion of the generating rotor and the gear of the intermediate wheel for generating rotor engage with each other.)	1) If the gear of the oscillating weight and the pinion of the intermediate wheel for generating rotor are intact, reassemble them to the movement. 2) Remove the broken piece of the generating rotor, and replace and lubricate the generating rotor. (Overhaul and clean if necessary.)
The current consumption for the whole movement exceeds the standard value.	1) When the measurement is made, the IC is still in the quick start mode. (When the current consumption measures about 200 μ A, it is likely that the IC is in the quick start mode.) 2) The load applied on the gear train, etc. has increased, and the driving pulse to compensate it has been generated.	1) After connecting the tester, move the oscillating weight more quickly for a longer period of time, and then, make the measurement again. 2) If the current consumption for the circuit block alone is within the standard value range, overhaul and clean the movement parts, and then, make the measurement again.
The current consumption for the circuit block alone exceeds the standard value.	1) The light from outside the movement is affecting the measurement. 2) When the measurement is made, the IC is still in the quick start mode. (When the current	1) Shut out the light, and make the measurement again. 2) Switch the IC to the normal mode, and make the measurement again.

TECHNICAL GUIDE**Cal.7D46A/7D48A**

	consumption measures about 200 μ A, it is likely that the IC is in the quick start mode.) 3) The IC is out of order.	3) Replace the circuit block.
Swinging the watch while the power save function is active will not activate the time relay function. (Swinging the watch starts the second hand moving at two-second intervals.)	The energy stored in the rechargeable battery has been depleted while the power save function is in operation.	Swing the watch until the second hand moves at one-second intervals, and activate the power save function manually to check if the time relay function can be activated.
Swinging the watch while the power save function is active will not activate the time relay function. (Swinging the watch will not start the second hand moving at all.)	There is electric leakage inside the hour and minute coil block.	Check for leakage of the hour and minute coil block. Replace the part if leakage is detected.
After the time relay function is activated, the hands do not make the quick movement smoothly, or the hands indicate a time that differs greatly from the correct time.	There is electric leakage inside the hour and minute coil block.	Check for leakage of the hour and minute coil block. Replace the part if leakage is detected.

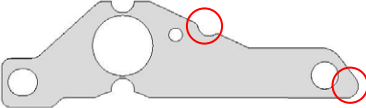

*For troubleshooting of defects that conventional quartz watches have in common, refer to the "TECHNICAL GUIDE, GENERAL INSTRUCTIONS".

7D** Technical Instruction

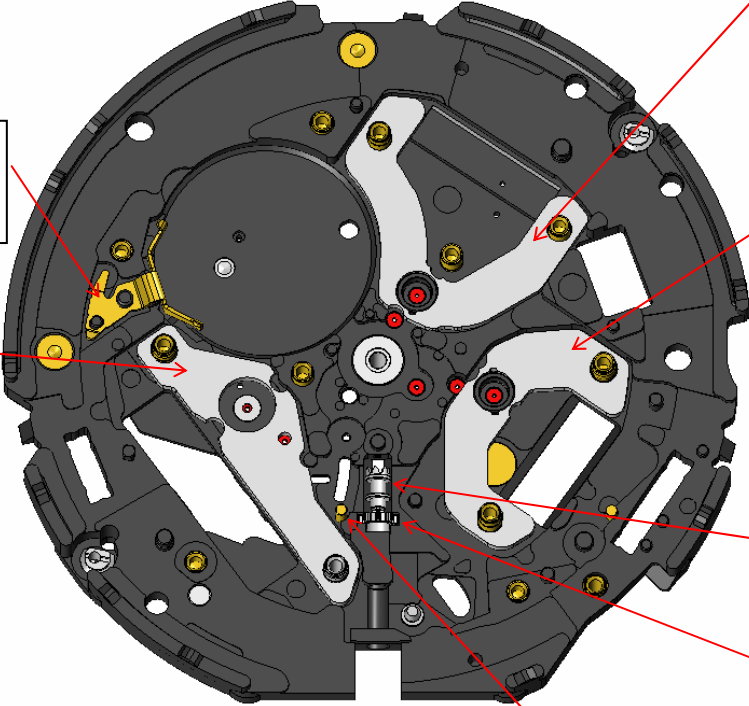
No.	PROSESS	ILLUSTRATIONS AND SPECIAL INSTRUCTIONS	
	Assembling the switching unit		
91	Set the main plate.	<p><91> Set the main plate.</p>	
	↓		
90	Set the lead pin for RZ1.		
	↓		
89	Set the hour and minute stator.	<p><86> Set the rechargeable battery connection (+).</p>	
	↓		
88	Set the second stator.		<p><88> Set the second stator. *When mounting, take care not to distort or deform the second stator. (To prevent deterioration of the motor)</p>
	↓		
87	Set the generating stator.	<p><87> Set the generating stator. *Distinction from the 5J-series counterpart See the red-circled parts, which are shaped to identify the 7J-series generating stator.</p>	<p><89> Set the hour and minute stator. *When mounting, take care not to distort or deform the hour and minute stator. (To prevent deterioration of the motor.)</p>
	↓		
86	Set the rechargeable battery connection (+).		
	↓		
85	Set the 1 st intermediate wheel for calendar corrector.	 <p>*When mounting, take care not to distort or deform the generating stator. (To prevent deterioration of electric power generation)</p>	<p><84> Set the clutch wheel.</p>
	↓		
84	Set the clutch wheel.		<p><85> Set the 1st intermediate wheel for calendar corrector.</p>
	↓		
			<p><90> Set the lead pin for RZ1. *Ensure that the lead pin for RZ1 is tightly mounted without any clearance.</p>

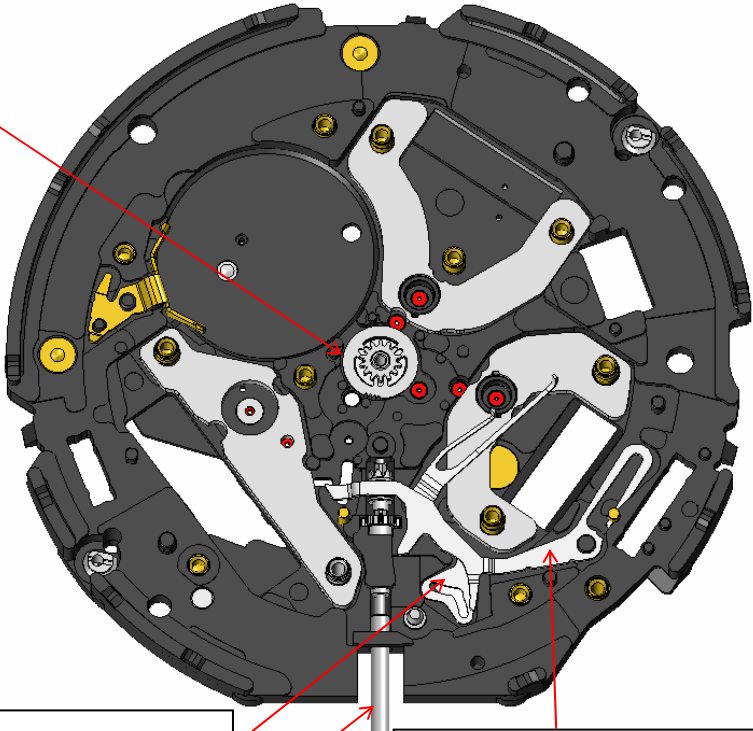

7D** Technical Instruction

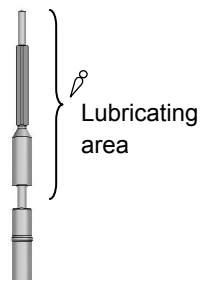
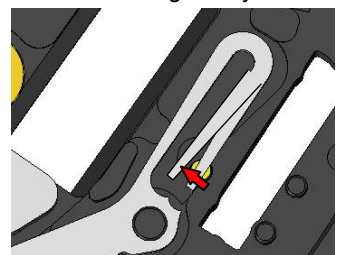
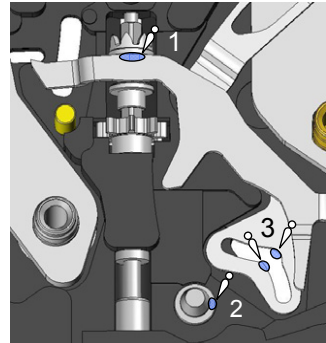
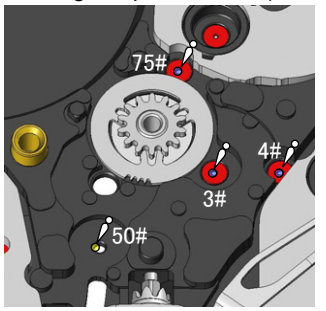
No.	PROCESS	ILLUSTRATIONS AND SPECIAL INSTRUCTIONS		
	Assembling the switching unit			
83	Set and lubricate the winding stem.			<p><82> Set and lubricate the center wheel & pinion.</p> <p>* Lubricating point: convex part (Refer to the illustration below.)</p> <p>*Type of oil, oil quantity: A0-3II-1 (To prevent parts from wearing)</p>
	↓			<p>*Lubricating point: inner edge of the ring (Refer to the illustration below.)</p>
82	Set and lubricate the center wheel & pinion.			<p>*Type of oil, oil quantity: A0-3II-1 (To prevent parts from wearing)</p>
	↓			<p>*Lubricating point: inner edge of the ring (Refer to the illustration below.)</p>
81	Set the train wheel setting lever.			<p>*Type of oil, oil quantity: A0-3II-1 (To prevent parts from wearing)</p>
	↓			
80	Set the yoke and hook the arm of it.			
	↓			<p>Lubricating points of the switching unit-1</p>
	-Stem of the setting lever			<p>2. Axes of the setting lever</p>
	-Point of contact between the yoke and clutch wheel	<p>*Type of oil, oil quantity: A0-3II-1 (To prevent parts from wearing)</p>		
	-Lower pivots of the wheels (4#, 3#, 50#, 75#)	<p>3. Guiding slit of the train wheel setting lever</p>		
	- Guiding slit of the train wheel setting lever	<p>*Type of oil, oil quantity: A0-3I-2 (To prevent parts from wearing)</p>		
		<p>4. Lower pivots of the wheels (4#, 3#, 50#, 75#)</p>		
		<p>*Type of oil, oil quantity: A0-3II-1 (To maintain good performance)</p>		
				
		<p><83> Set and lubricate the winding stem.</p>		
		<p>*Type of oil, oil quantity: A0-3 Lubricate the entire profile of the winding stem. (To prevent parts from wearing)</p>		
		<p>*Securely install the winding stem, giving it gentle rotations so that the flat face of the winding stem will be engaged with both the clutch wheel and the 1st intermediate wheel for calendar corrector.</p>		
		<p><81> Set the train wheel setting lever.</p>		
		<p><80> Set the yoke and hook the arm of it. Securely set the arm of the yoke inside the pin, taking care not to deform or damage the yoke.</p>		
				
		<p>Lubricating points of the switching unit-1</p>		
		<p>1. Point of contact between the yoke and clutch wheel</p>		
		<p>*Type of oil, oil quantity: A0-3III-1 (To prevent parts from wearing)</p>		
				
		<p>2. Axes of the setting lever</p>		
		<p>*Type of oil, oil quantity: A0-3II-1 (To prevent parts from wearing)</p>		
		<p>3. Guiding slit of the train wheel setting lever</p>		
		<p>*Type of oil, oil quantity: A0-3I-2 (To prevent parts from wearing)</p>		
		<p>4. Lower pivots of the wheels (4#, 3#, 50#, 75#)</p>		
		<p>*Type of oil, oil quantity: A0-3II-1 (To maintain good performance)</p>		
				

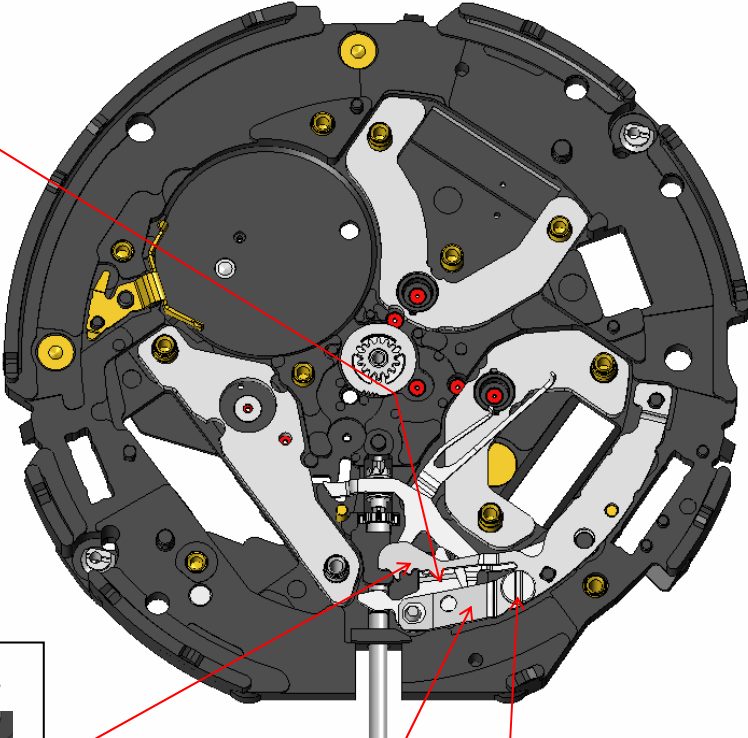
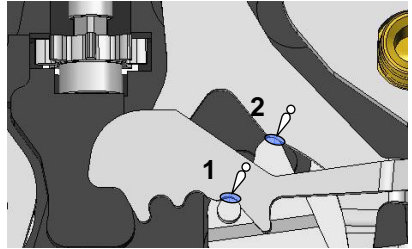
No.	PROCESS	ILLUSTRATIONS AND SPECIAL INSTRUCTIONS			
79	Set the setting lever. ↓	<p data-bbox="427 240 741 268"><79> Set the setting lever.</p> <p data-bbox="427 276 775 560">*Before setting the setting lever, put the train wheel setting lever inside the frame of the main plate (as illustrated in blue). This will make the engagement between the pin of the setting lever and the guiding slit of the train wheel setting lever easier.</p> 	<div data-bbox="1608 252 2136 284">Lubricating points of the switching unit-2</div> <ol data-bbox="1615 320 2130 576" style="list-style-type: none"> 1. Point of engagement between the yoke and setting lever *Type of oil, oil quantity: A0-3II-1 (To prevent parts from wearing) 2. Point of contact between the yoke and setting lever *Type of oil, oil quantity: A0-3II-1 (To prevent parts from wearing) 3. Axis of the setting wheel *Type of oil, oil quantity: A0-3II-1 (To prevent parts from wearing) 		
78	Set the setting lever spring. ↓				
77	Tighten the setting lever spring. (33#) ↓				
	Hook the arm of the setting lever. ↓				
	Lubricating points of the switching unit-2				
	-Point of engagement between the yoke and setting lever				
	-Point of contact between the yoke and setting lever				
	-Axis of the setting wheel				

<79> Set the setting lever.
*Before setting the setting lever, put the train wheel setting lever inside the frame of the main plate (as illustrated in blue). This will make the engagement between the pin of the setting lever and the guiding slit of the train wheel setting lever easier.

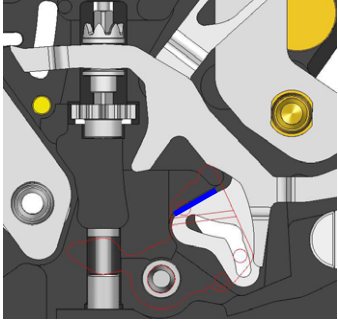

Hook the arm of the setting lever.

<78> Set the setting lever spring.

<77> Tighten the setting lever spring.

Lubricating points of the switching unit-2

1. Point of engagement between the yoke and setting lever
*Type of oil, oil quantity: A0-3II-1
(To prevent parts from wearing)
2. Point of contact between the yoke and setting lever
*Type of oil, oil quantity: A0-3II-1
(To prevent parts from wearing)
3. Axis of the setting wheel
*Type of oil, oil quantity: A0-3II-1
(To prevent parts from wearing)

7D** Technical Instruction

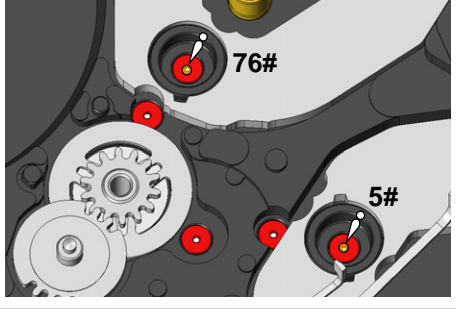
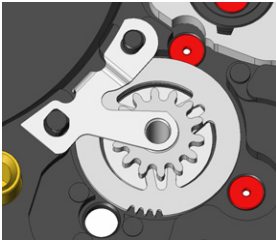
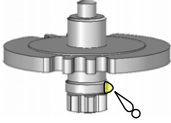
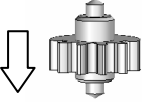
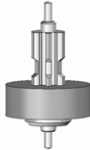
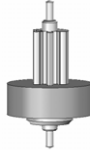
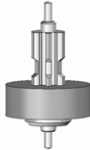
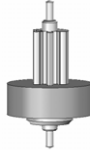
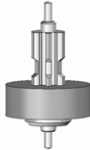
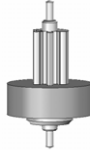
No.	PROSESS	ILLUSTRATIONS AND SPECIAL INSTRUCTIONS					
	Assembling the wheels						
	Lubricate the lower pivots of the wheels.	<p>Lubricate the lower pivots of the wheels. *Type of oil, oil quantity: A0-2II-1 (To maintain good performance)</p> 					
	↓						
76	Set the spacer for center wheel and pinion.						
	↓						
75	Set and lubricate the minute wheel & pinion.						
	↓						
74	Set the intermediate minute wheel.						
	↓						
73	Set the setting wheel.	<p><76> Set the spacer for center wheel and pinion. *Firmly press down the point of engagement to securely set it without any clearance.</p> 					
	↓						
72	Set the hour and minute rotor.						
	↓						
71	Set the second rotor.						
	↓						
70	Set the generating rotor.						
		<p><70> Set the generating rotor.</p>					
		<p><71> Set the second rotor. * Make sure to set the correct rotor. (The second rotor and the hour and minute rotor are different in their specification.)</p>					
		<p><75> Set and lubricate the minute wheel & pinion. *Type of oil, oil quantity: A0-3II-1 (To prevent parts from wearing)</p> 					
		<p><74> Set the intermediate minute wheel. *Make sure the intermediate minute wheel is put in the correct direction. (See the illustration below.)</p> 					
		<p><72> Set the hour and minute rotor. *Make sure to set the correct rotor. (The hour and minute rotor and the second rotor are different in their specification.)</p> <p>Distinction between the hour and minute rotor and the second rotor</p> <table border="0" style="width: 100%;"> <tr> <td style="text-align: center;">Hour and minute rotor</td> <td style="text-align: center;">Second rotor</td> </tr> <tr> <td style="text-align: center;"></td> <td style="text-align: center;"></td> </tr> </table>		Hour and minute rotor	Second rotor		
Hour and minute rotor	Second rotor						
							

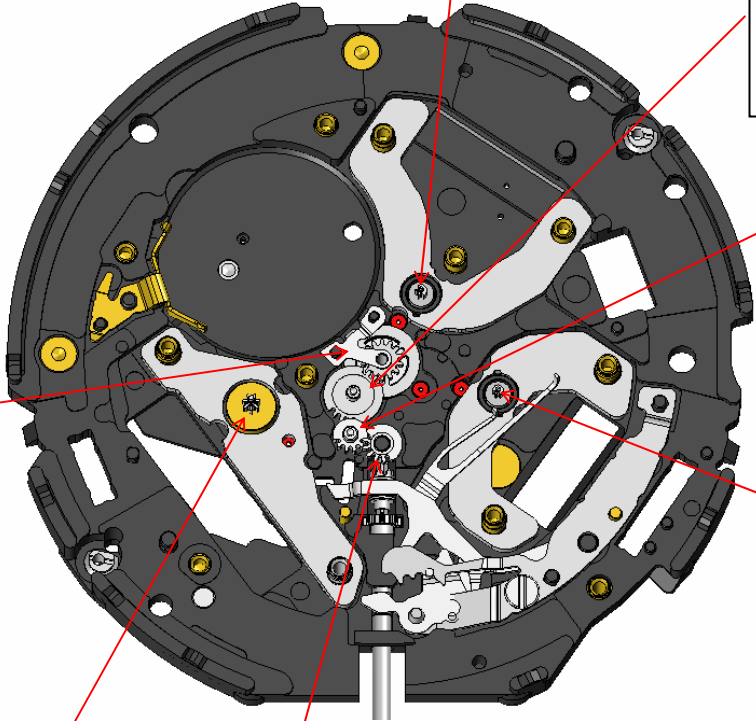

7D** Technical Instruction

No.	PROSESS	ILLUSTRATIONS AND SPECIAL INSTRUCTIONS
69	Set the 3rd wheel & pinion.	<div data-bbox="450 260 1016 323" style="border: 1px solid black; padding: 5px;"> <67> Set the intermediate second wheel. </div> <div data-bbox="1160 244 1800 359" style="border: 1px solid black; padding: 5px;"> <69> Set the 3rd wheel & pinion. * The 3rd wheel & pinion has three holes for distinction from the 5J2-series counterpart. </div>
68	Set the 4th wheel & pinion.	<div data-bbox="1288 387 1977 512" style="border: 1px solid black; padding: 5px;"> <68> Set the 4th wheel & pinion. *The 4th wheel & pinion has four holes for distinction from the 5J2- series counterpart. </div>
67	Set the intermediate second wheel.	
66	Lubricate the second wheel & pinion.	<div data-bbox="1624 592 2112 671" style="border: 1px solid black; padding: 5px;"> <64> Tighten the train wheel bridge screw. </div>
65	Set the train wheel bridge and check the pivot hole.	
64	Tighten the train wheel bridge screw.	<div data-bbox="994 1090 1413 1169" style="border: 1px solid black; padding: 5px;"> <65> Set the train wheel bridge and check the pivot hole. </div>
		<div data-bbox="405 986 949 1157" style="border: 1px solid black; padding: 5px;"> <66> Lubricate the second wheel & pinion. *Lubricating points: convex part (Refer to the illustration below.) *Type of oil, oil quantity: A0-3II-1 (To prevent parts from wearing) </div> <div data-bbox="443 1185 562 1422" style="text-align: center;">  </div> <div data-bbox="600 1201 936 1393" style="color: blue;"> Lubricate with an appropriate amount of oil, as excessive lubrication may cause the second hand to wiggle while the watch resumes from power save mode. </div>

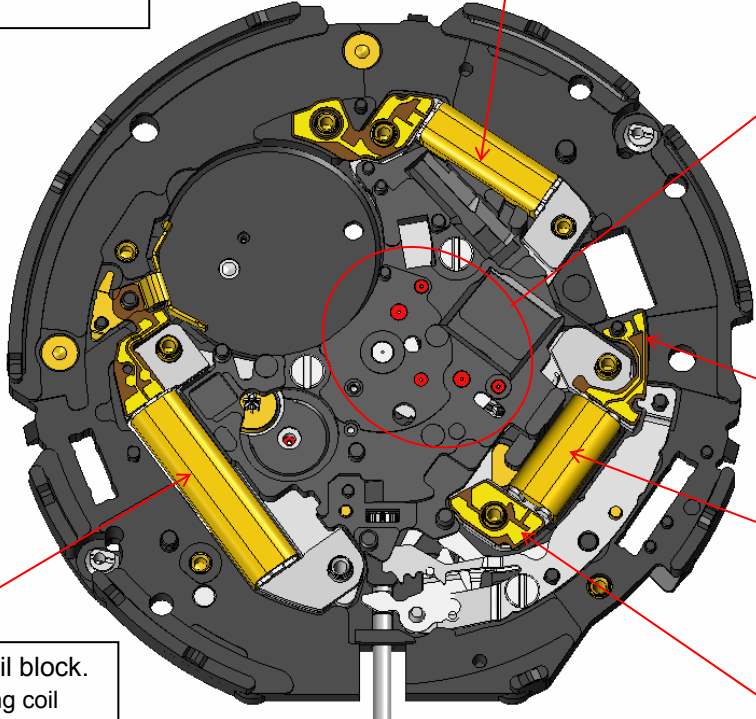
No.	PROSESS	ILLUSTRATIONS AND SPECIAL INSTRUCTIONS				
	Lubricate the upper pivots of the wheels. (5#, 76#, 4#, 3#, 74#, 75#, Tips of the teeth of the pinion of generating rotor 66#)	<p>Check each coil block resistance.</p> <p>*Measure the coil block resistance after securely installing each coil block to the movement.</p> <p>Hour and minute coil block Coil block for driving: 1.00kΩ–1.25kΩ Coil block for detection: 270Ω– 330Ω Second coil block 2.00kΩ – 2.45kΩ Generating coil block 360Ω – 420Ω</p>	<p><62> Set the second coil block.</p> <p>*When mounting the second coil block, take care not to deform or deform the coil block core. (To prevent deterioration of the motor)</p>	<p>Lubricate the upper pivots of the wheels.</p> <p>◆ 5#, 76# *Type of oil, oil quantity: A0-2II-1 (To maintain good performance)</p> <p>◆ 4#, 3#, 74#, 75# *Type of oil, oil quantity: A0-3II-1 (To maintain good performance)</p> <p>◆ Tips of the teeth of the pinion of the generating rotor (66#) *Type of oil, oil quantity: A0-3II-2 (To prevent parts from wearing)</p> 		
63	↓ Set the hour and minute coil block.					<p>Pattern for checking the coil for detection</p>
62	↓ Set the second coil block.					<p><61> Set the generating coil block.</p> <p>*When mounting the generating coil block, take care not to deform or deform the coil block core. (To prevent deterioration of the motor)</p>
61	↓ Set the generating coil block.					
	↓ Check each coil block resistance.					

7D** Technical Instruction

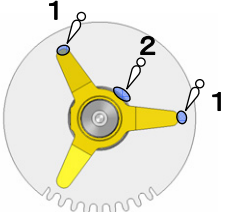
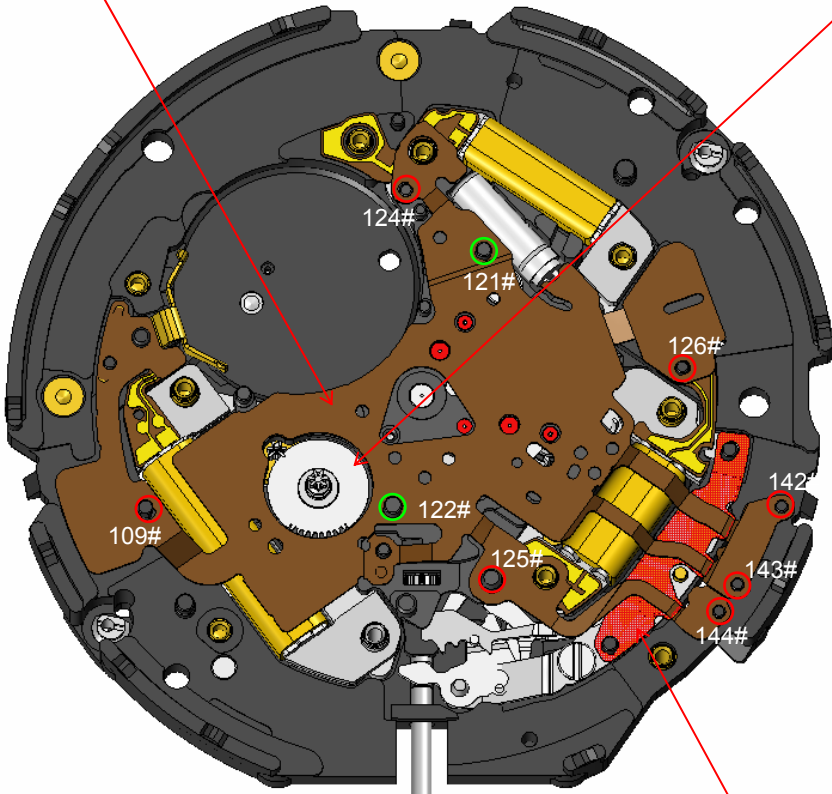
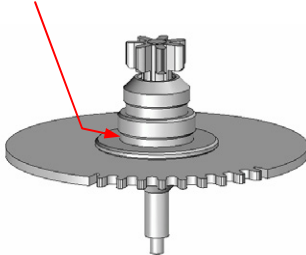
No.	PROSESS	ILLUSTRATIONS AND SPECIAL INSTRUCTIONS
	Assembling the circuit	
60	Set the insulator for circuit block. ↓	<div data-bbox="436 236 1547 424" style="border: 1px solid black; padding: 5px;"> <p><59> Set the circuit block. *Firmly press down the points of engagement to securely set it in position.</p> <p>Positioning guide tubes : 121#, 124# (green-circled in the illustration.) Points of engagement : 109#, 124#, 125#, 126#, 142#, 143#, 144# (red-circled in the illustration)</p> </div>
	Check the current consumption for the circuit block. ↓	
59	Set the circuit block. ↓	
58	Set and lubricate the intermediate wheel for generating rotor.	<div data-bbox="1630 236 2152 496" style="border: 1px solid black; padding: 5px;"> <p><58> Set and lubricate the intermediate wheel for generating rotor. Position (1) shown in the illustration below *Type of oil, oil quantity: A0-3II-2 (To prevent parts from wearing) Position (2) shown in the illustration below *Type of oil, oil quantity: A0-3II-1 (To prevent parts from wearing)</p>  </div>
		<div data-bbox="786 443 1615 1241" style="text-align: center;">  </div> <div data-bbox="1630 762 2152 979" style="border: 1px solid black; padding: 5px; margin-top: 10px;"> <p>*Distinction between the 7D-series intermediate wheel for generating rotor and the 5J-series counterpart At the position shown by the red arrow, the 7D-series intermediate wheel for generating rotor has a groove, while the 5J-series counterpart does not.</p>  </div> <div data-bbox="1397 1362 1912 1422" style="border: 1px solid black; padding: 5px; margin-top: 10px; text-align: center;"> <p><60> Set the insulator for circuit block.</p> </div>

7D** Technical Instruction

No.	PROSESS	ILLUSTRATIONS AND SPECIAL INSTRUCTIONS
57	Set the oscillating weight bridge and check the pivot hole.	
	↓	
56	Set the circuit block cover C.	
	↓	<div data-bbox="432 432 887 544" data-label="Text"> <p><57> Set the oscillating weight bridge and check the pivot hole.</p> </div>
55	Tighten the circuit block cover C screws. (28#, 101#, 103#, 401#)	
	↓	
54	Set the circuit block cover D.	
		<div data-bbox="1697 280 2136 746" data-label="Image"> </div>
		<div data-bbox="840 400 1675 1230" data-label="Image"> </div>
		<div data-bbox="432 1174 936 1294" data-label="Text"> <p><55> Tighten the circuit block cover C screws. (28#, 101#, 103#, 401#)</p> </div>
		<div data-bbox="1585 1198 2022 1270" data-label="Text"> <p><54> Set the circuit block cover D.</p> </div>

7D* * Technical Instruction

No.	PROCESS	ILLUSTRATIONS AND SPECIAL INSTRUCTIONS
	Assembling the power section	
7	Set the rechargeable battery unit.	<div data-bbox="488 268 1283 440" style="border: 1px solid black; padding: 5px;"> <p><7> Set the rechargeable battery unit. *Stretching out the plus terminal to mount the rechargeable battery unit. *Take care not to deform the minus terminal when removing the rechargeable battery unit. (Remove the battery portion first.)</p> </div>
	↓	
6	Set the insulator for rechargeable battery.	<div data-bbox="1518 400 2159 616" style="border: 1px solid black; padding: 5px;"> <p><6> Set the insulator for rechargeable battery. *Firmly press down the points of engagement (132#, 107#) to securely set it in position. -Positioning guide tubes: 131#, 132# -Points of engagement: 132#, 107#</p> </div>
	↓	
5	Set the rechargeable battery clamp.	
	↓	
4	Tighten the rechargeable battery clamp screws. (102#, 35#)	<div data-bbox="1536 678 2159 879" style="border: 1px solid black; padding: 5px;"> <p><5> Set the rechargeable battery clamp. *Firmly press down the point of engagement (132#) to securely set it in position. -Positioning guide tubes: 132#, 107# -Point of engagement: 132#</p> </div>
		<div data-bbox="629 469 1518 1326" style="text-align: center;"> </div>
		<div data-bbox="1536 1046 2136 1219" style="border: 1px solid black; padding: 5px;"> <p><4> Tighten the rechargeable battery clamp screws. (102#, 35#)</p> </div>

No.	PROCESS	ILLUSTRATIONS AND SPECIAL INSTRUCTIONS
3	Set the oscillating weight wheel. ↓	<div data-bbox="405 277 707 376" style="border: 1px solid black; padding: 5px;"> <3> Set the oscillating weight wheel. </div>
2	Set the oscillating weight. ↓	<div data-bbox="741 328 1267 400" style="border: 1px solid black; padding: 5px;"> <1> Tighten the oscillating weight screw. </div>
1	Tighten the oscillating weight screw. ↓	
	Check the performance of power generation. ↓	<div data-bbox="1256 475 2011 632" style="border: 1px solid black; padding: 5px;"> Check the performance of power generation. * The increase in voltage after spinning the oscillating weight should not be less than 50 mV. </div>
	Check the movement of the oscillating weight. ↓	<div data-bbox="1256 695 2011 836" style="border: 1px solid black; padding: 5px;"> Check the movement of the oscillating weight. *Ensure that the oscillating weight rotates smoothly without any friction or resistance. </div>
	Charge the rechargeable battery.	
		<div data-bbox="1256 983 2020 1155" style="border: 1px solid black; padding: 5px;"> Charge the rechargeable battery. * Charge the rechargeable battery until the voltage reaches 1.3V or higher by using a recharger or by your hand movement. (To check the PTP movement) </div>
		<div data-bbox="421 1171 712 1270" style="border: 1px solid black; padding: 5px;"> <2> Set the oscillating weight. </div>

<3> Set the oscillating weight wheel.

<1> Tighten the oscillating weight screw.

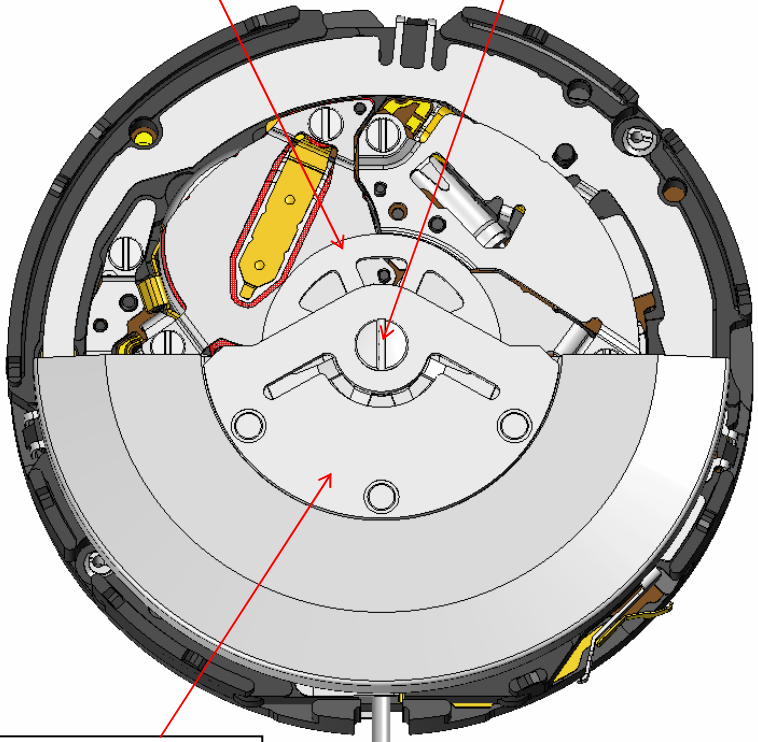

Check the performance of power generation.
 * The increase in voltage after spinning the oscillating weight should not be less than 50 mV.

Check the movement of the oscillating weight.
 *Ensure that the oscillating weight rotates smoothly without any friction or resistance.

Charge the rechargeable battery.
 * Charge the rechargeable battery until the voltage reaches 1.3V or higher by using a recharger or by your hand movement.
 (To check the PTP movement)

<2> Set the oscillating weight.

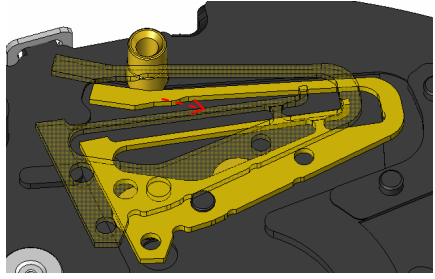
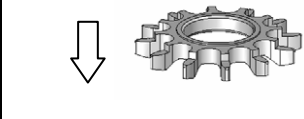
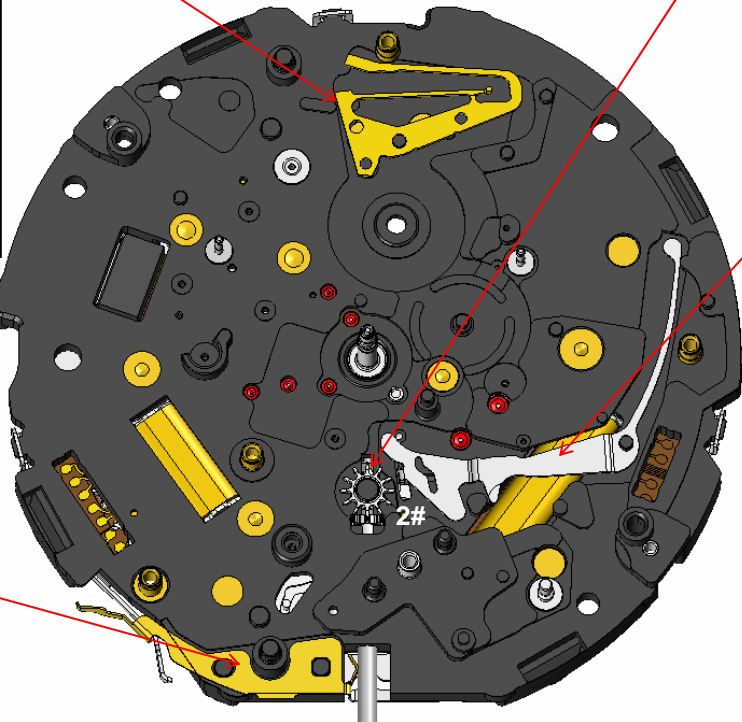
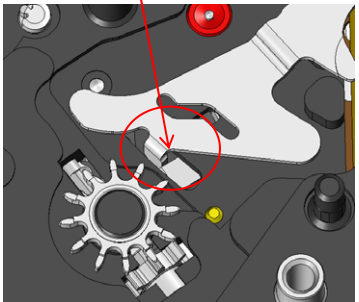
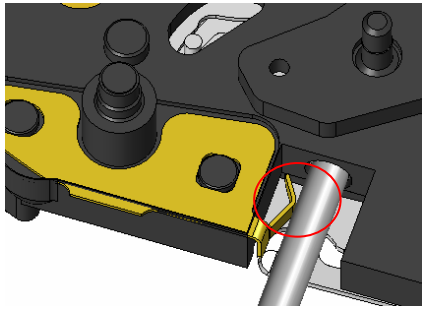

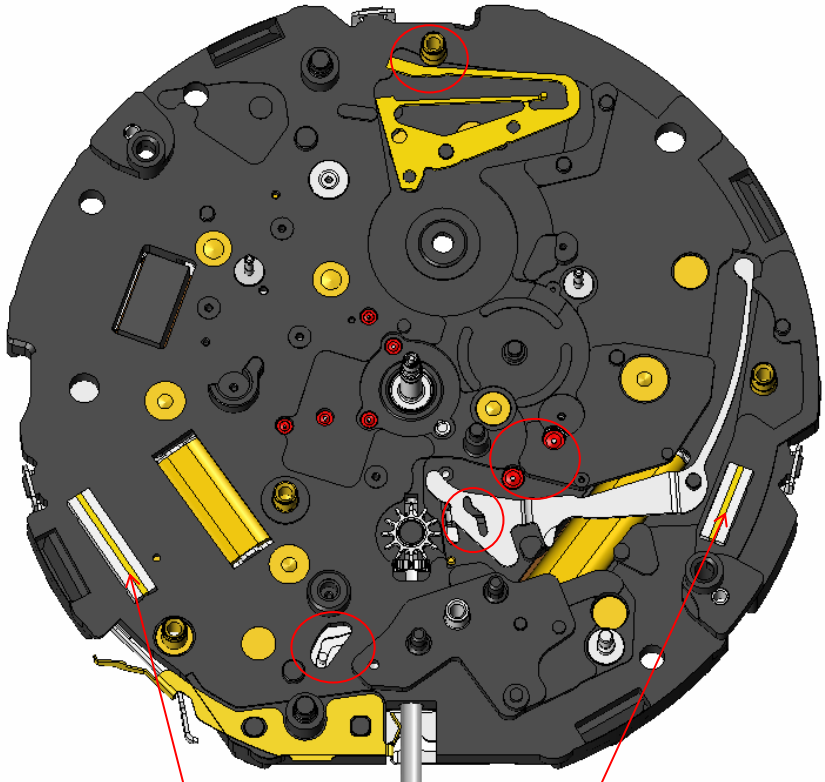
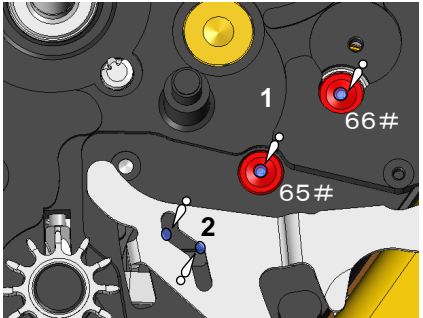
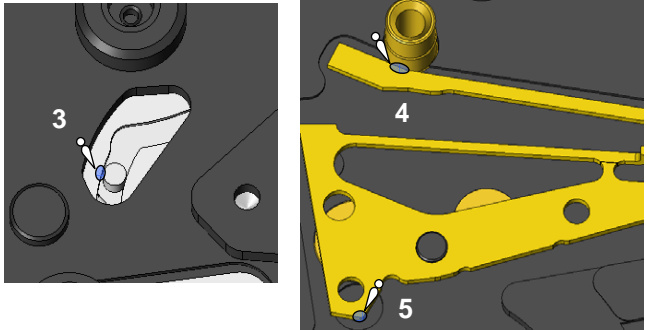
No.	PROSESS	ILLUSTRATIONS AND SPECIAL INSTRUCTIONS			
	Assembling the calendar circuit				
51	Set the contact point spring. ↓	<p><49> Set the control jumper and hook it. *Put the tail of the spring inside the pin, and then insert the control jumper from the side to engage it with the guide pin of the main plate.</p> 	<p><50> Set the 2nd intermediate wheel for calendar corrector.</p> 		
50	Set the 2nd intermediate wheel for calendar corrector. ↓				
49	Set the control jumper and hook it. ↓			<p><48> Set the ratchet lever and hook it. *While the winding stem is at the first click position, securely set the tip of the ratchet lever inside the yoke.</p> 	
	Pull out the winding stem from the "0" position to the first position. ↓				
48	Set the ratchet lever and hook it.	<p><51> Set the contact point spring. *Set the contact point spring making a good connection with the surface of the winding stem.</p> 			

No.	PROCESS	ILLUSTRATIONS AND SPECIAL INSTRUCTIONS
Lubrication		
	-66#, 65# lower pivots	
	-Guiding slit of the ratchet lever	
	-Guiding slit of the train wheel setting lever	
	-Arm of the control jumper	
	-Corner point of the control jumper	
	↓	<p>Lubrication (red-circled parts in the illustration to the left)</p> <ol style="list-style-type: none"> 1. 66#, 65# lower pivots *Type of oil, oil quantity: A0-3II-1 (To prevent parts from wearing) 2. Guiding slit of the ratchet lever *Type of oil, oil quantity: A0-3II-2 (To prevent parts from wearing) 3. Guiding slit of the train wheel setting lever *Type of oil, oil quantity: A0-3II-1 (To prevent parts from wearing) 4. Arm of the control jumper *Type of oil, oil quantity: A0-3II-1 (To keep the smooth movement) 5. Corner point of the control jumper *Type of oil, oil quantity: A0-3II-1 (To prevent parts from wearing)  
47	Set the A connector.	
	↓	
46	Set the B connector.	

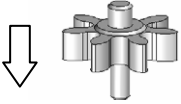
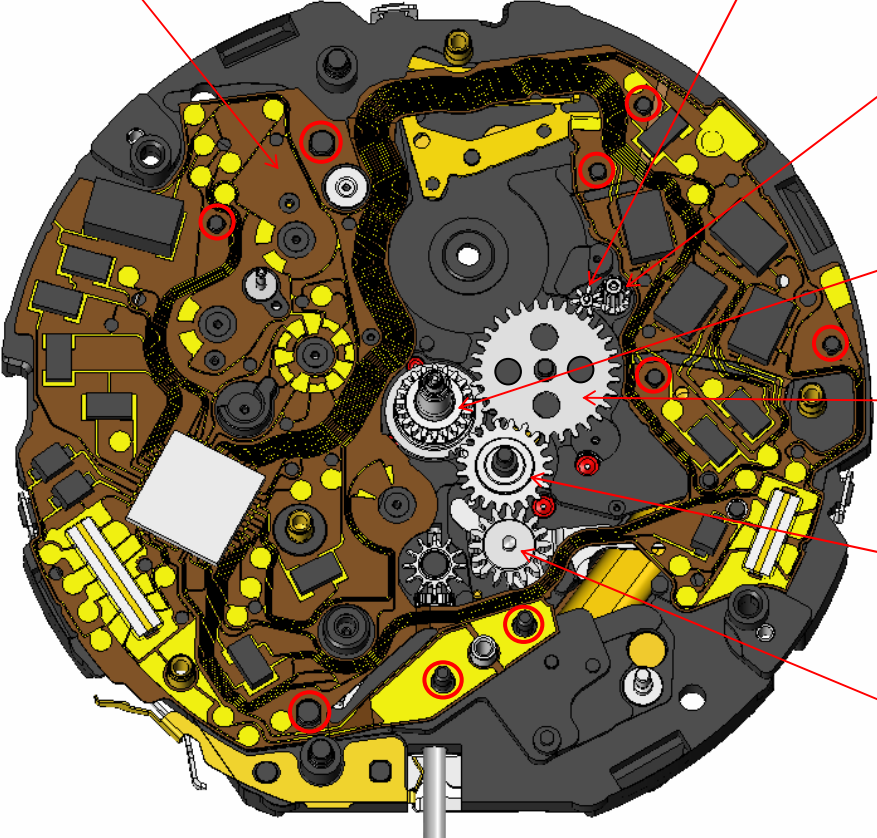
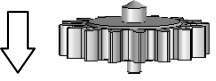
7D** Technical Instruction

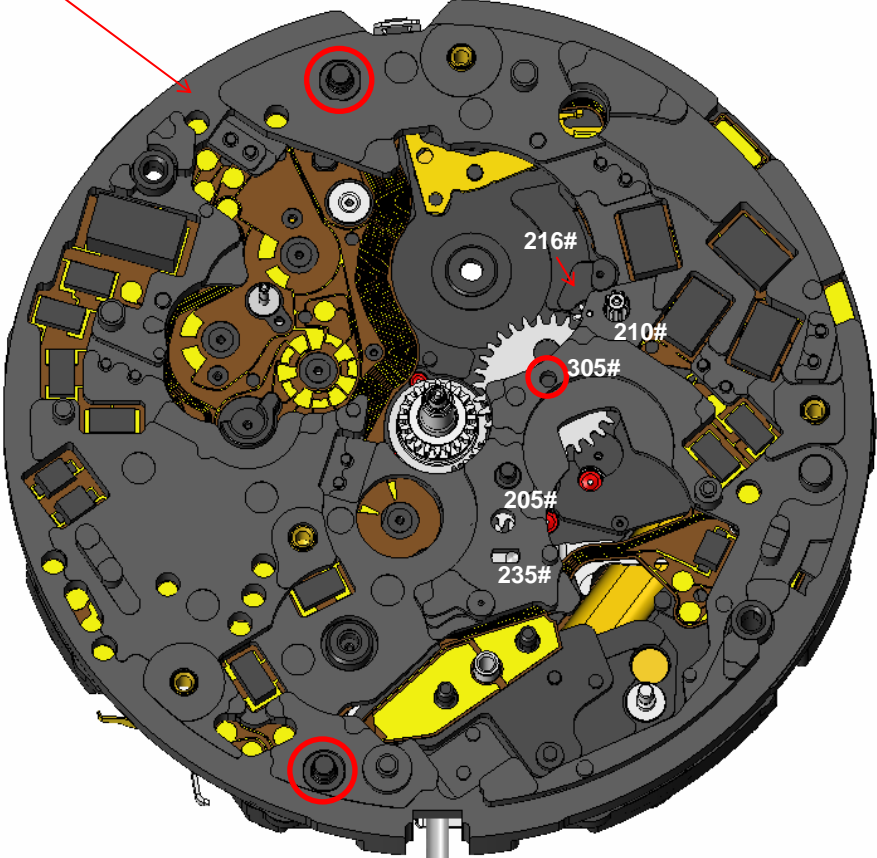
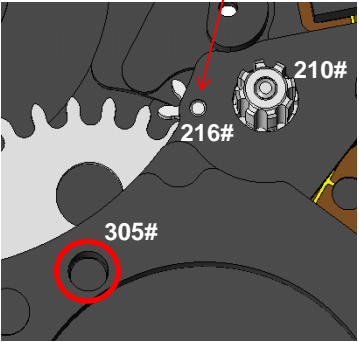
No.	PROSESS	ILLUSTRATIONS AND SPECIAL INSTRUCTIONS		
45	Set the circuit block for calendar. ↓	<p><45> Set the circuit block for calendar. *Firmly press down the points of engagement (9 red-circled points in the illustration below) down to securely set it in position. *Never push the lead portion directly as the lead wire of the circuit pattern is thin and could be cut easily.</p>	<p><39> Set the date driving wheel for ten's digit. *Make sure the date driving wheel for ten's digit is put in the correct direction. (See the illustration below.)</p> 	
44	Set the hour wheel. ↓			
43	Set the 3rd intermediate wheel for calendar. ↓		<p><40> Set the pinion for ten's digit.</p>	
42	Set the 4th intermediate wheel for calendar corrector. ↓			<p><44> Set the hour wheel.</p>
41	Set the 3rd intermediate wheel for calendar corrector. ↓			<p><43> Set the 3rd intermediate wheel for calendar.</p>
40	Set the pinion for ten's digit . ↓			<p><42> Set the 4th intermediate wheel for calendar corrector. *Make sure that the pinion and the teeth are properly engaged.</p>
39	Set the date driving wheel for ten's digit .			<p><41> Set the 3rd intermediate wheel for calendar corrector. *Make sure the 3rd intermediate wheel for calendar corrector is put in the correct direction. (See the illustration below.)</p> 

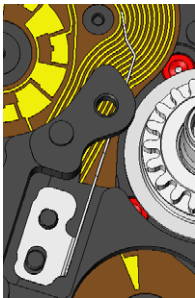
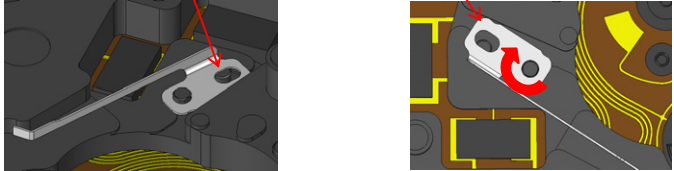
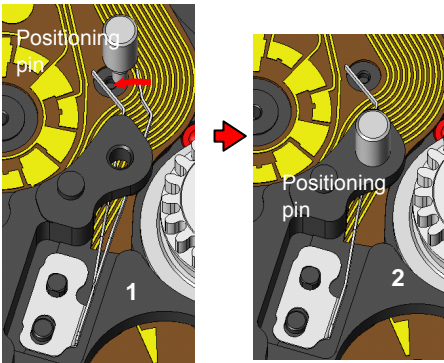
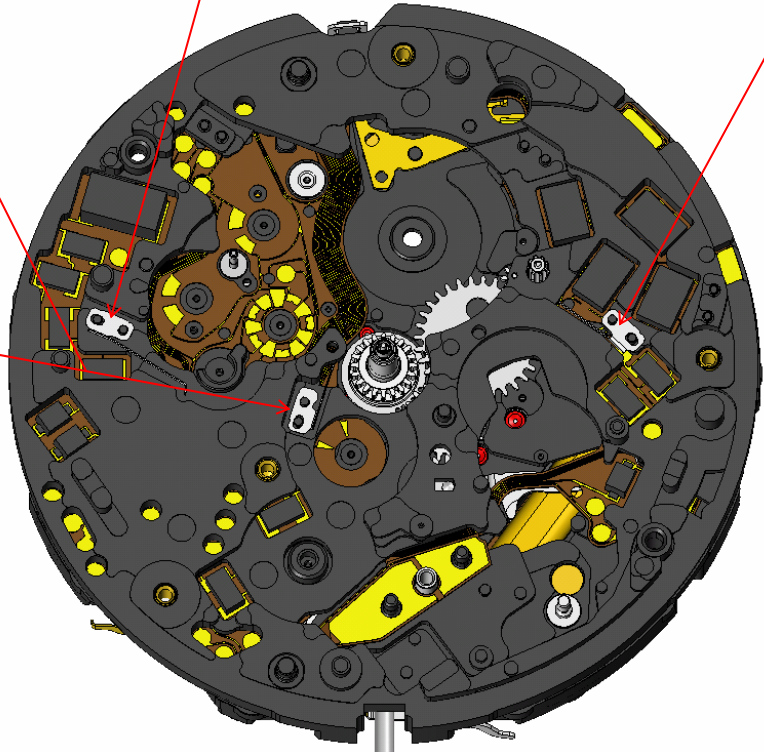
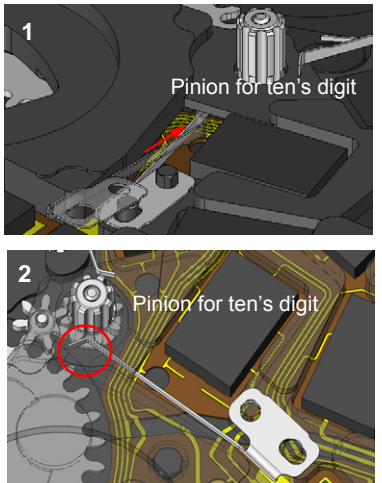
No.	PROSESS	ILLUSTRATIONS AND SPECIAL INSTRUCTIONS
38	Set the circuit block spacer for calendar.	<p data-bbox="427 252 853 312"><38> Set the circuit block spacer for calendar.</p> <p data-bbox="427 320 853 443">*Firmly press down the points of engagement (3 red-circled points in the illustration below) to securely set it in position.</p> <p data-bbox="427 451 853 603">*Ensure that the 305# portion is securely pressed down. Failing to do so will make the 216# unable to engage with the 210# properly. After pressing it down, check the pivot hole of 216#.</p>  

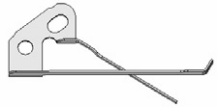

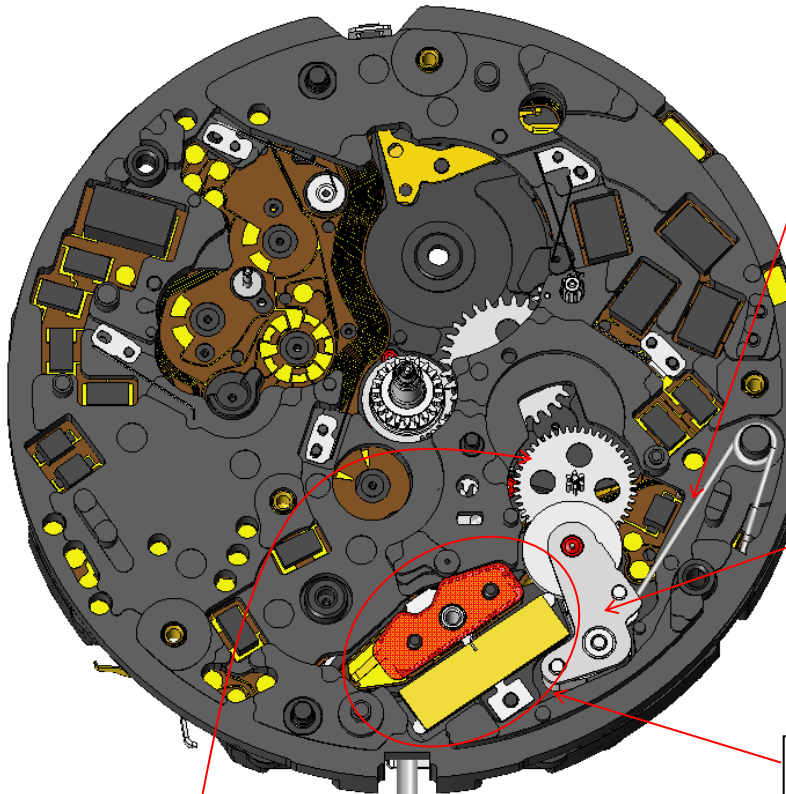
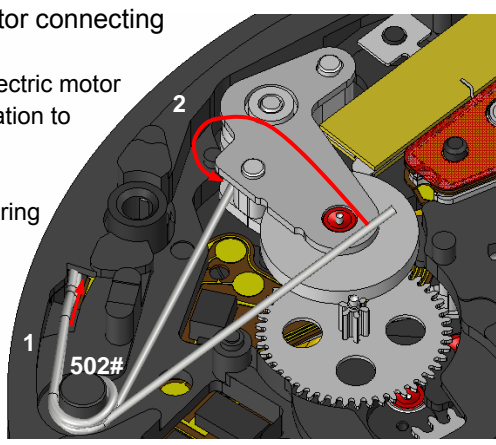
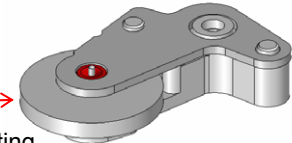
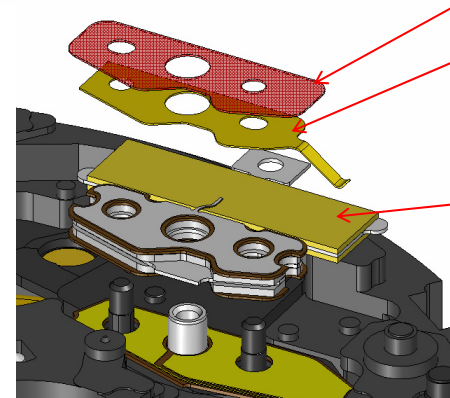
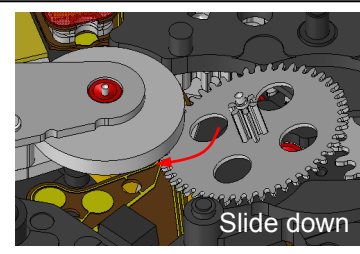
No.	PROCESS	ILLUSTRATIONS AND SPECIAL INSTRUCTIONS	
37	Set the jumper for ten's digit .		
36	Set the spring for intermediate wheel for month indicator .	<p><36> Set the spring for intermediate wheel for month indicator.</p> <p>*Firmly press down the point of engagement.</p> 	<p><35> Tentatively set the jumper for month.</p> <p>*Set the jumper tentatively as shown below. (To install the calendar wheels more effectively)</p> <ol style="list-style-type: none"> Put the jumper for month on the outer dowel. Rotate the jumper until it is fit to the frame of the circuit block spacer for calendar. 
◆	Set the positioning guide pin for the spring for intermediate wheel for month indicator and hook the spring for intermediate wheel for month indicator .		
35	Tentatively set the jumper for month.	<p>◆ Set the positioning guide pin for the spring for intermediate wheel for month indicator and hook the spring for intermediate wheel for month indicator.</p> <p>*While pushing the spring outward, set the positioning pin (1 in the illustration below) and then hook it (2 in the illustration below).</p> <p>Note) You can install the spring for intermediate wheel for month indicator without using the positioning pin.</p> 	
		<p><37> Set the jumper for ten's digit.</p> <p>*Insert the jumper for ten's digit from an angle to beneath the circuit block spacer for calendar (illustration 1 below), and then set the jumper contacting the pinion for ten's digit as shown red-circled in the illustration 2.</p> <p>*After setting the jumper for ten's digit, firmly press down the point of engagement to securely set it in position.</p> <p>*Rotate date driving wheel for ten's digit to check if the pinion for ten's digit rotates smoothly.</p>  <div data-bbox="1684 1072 2168 1455" style="border: 1px dashed black; padding: 5px;"> <p>Distinction among the different types of jumpers</p> <p>Jumper for ten's digit Jumper for month </p> <p>Jumper for year Spring for intermediate wheel for month indicator </p> <p>Jumper for units digit </p> </div>	

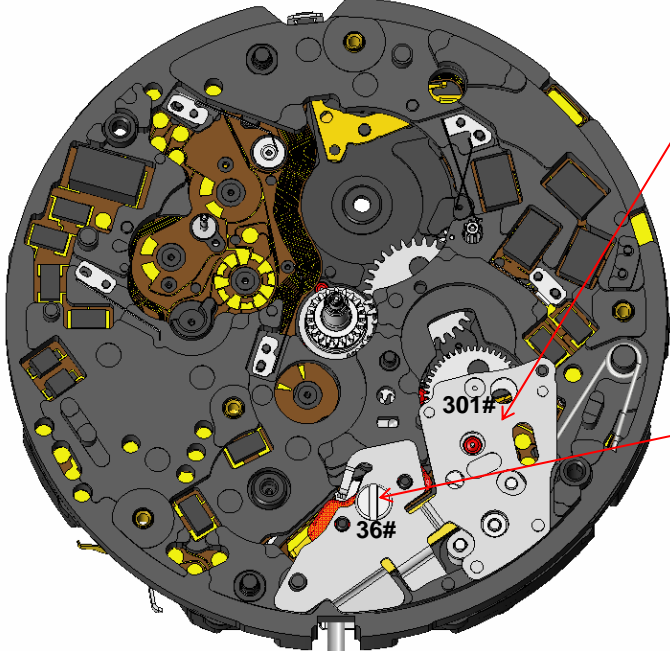
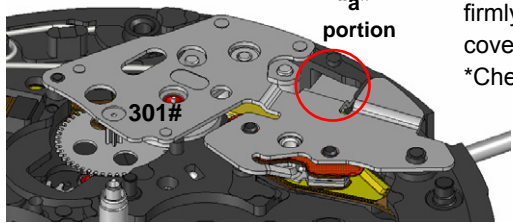
No.	PROCESS	ILLUSTRATIONS AND SPECIAL INSTRUCTIONS	
	Assembling the piezoelectric motor		
34	Set the piezoelectric stator block.		<p><29> Set the piezoelectric motor connecting spring and hook it. *How to set and hook the piezoelectric motor connecting spring (See the illustration to the right.)</p> <ol style="list-style-type: none"> 1. While inserting the tip of the piezoelectric motor connecting spring into the gap with the circuit block spacer for calendar, set it to engage with the dowel of the spacer (502#). 2. Hook the spring up to the lateral surface of the piezoelectric red block. 
33	Set the piezoelectric motor lead plate .		<p><31> Set the piezoelectric rotor block. *Make sure that there are no scratches, dirt, dusts or stains on the lateral surface of the wheel of the rotor; check the condition of the wheel before mounting. (To prevent deterioration of the piezoelectric motor)</p> 
32	Set the insulator for piezoelectric motor.		<p><32-34></p>  <ul style="list-style-type: none"> ◆ 32 Set the insulator for piezoelectric motor. ◆ 33 Set the piezoelectric motor lead plate. *Firmly press down the point of engagement to securely set it in position. ◆ 34 Set the piezoelectric stator block. *Handle with care not to distort or deform it. *Hold the lead board side when handling the piezoelectric stator block. (To prevent deterioration of the piezoelectric motor)
31	Set the piezoelectric rotor block.		
30	Set the 1st intermediate wheel for calendar.		
29	Set the piezoelectric motor connecting spring and hook it.	<p><30> Set the 1st intermediate wheel for calendar. *Make sure that the pinion of the piezoelectric rotor and the teeth of the 1st intermediate wheel for calendar are properly engaged. (Refer to the illustration to the right.)</p>  <p style="text-align: right;">Slide down</p>	

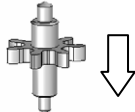
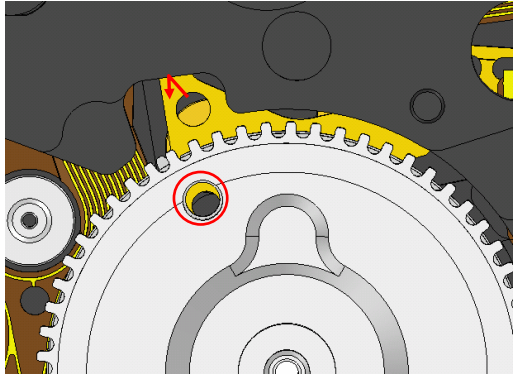
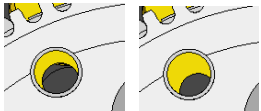
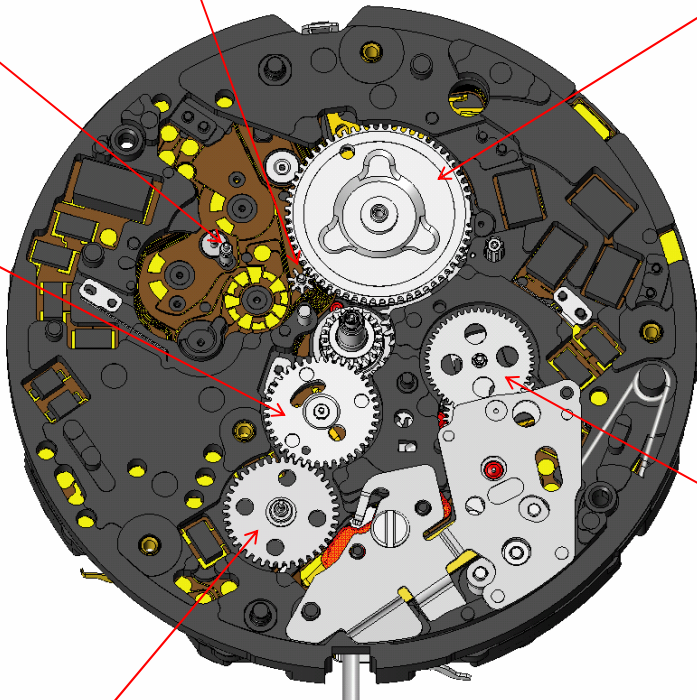
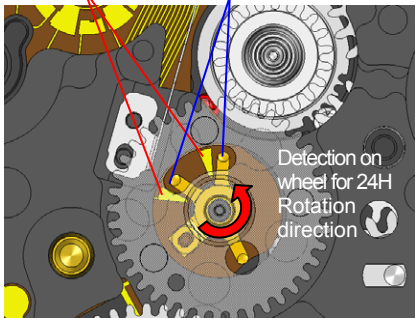
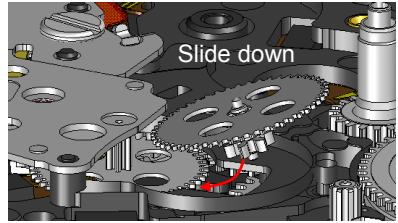
No.	PROSESS	ILLUSTRATIONS AND SPECIAL INSTRUCTIONS
28	Set the piezoelectric motor cover.	 <div data-bbox="1249 220 2136 560" style="border: 1px solid black; padding: 5px;"> <p><28> Set the piezoelectric motor cover.</p> <p>*Insert the "a" portion beneath the circuit block spacer for calendar to firmly set the piezoelectric motor cover. (See the illustration below.)</p> <p>*Check the pivot hole 301#.</p>  </div> <div data-bbox="1249 587 2011 775" style="border: 1px solid black; padding: 5px;"> <p><27> Tighten the screw for piezoelectric motor cover. (36#)</p> <p>*Make sure to set the correct screw.</p> </div> <div data-bbox="1249 866 1841 1054" style="border: 1px solid black; padding: 5px;"> <p>Check the PTP drive.</p> <p>*Ensure that the voltage of the rechargeable battery reaches 1.3v or higher, otherwise it will not work.</p> </div>
	↓	
27	Tighten the screw for piezoelectric motor cover. (36#)	
	↓	
	Push the winding stem back in from the first position to the original position.	
	↓	
	Check the PTP drive.	

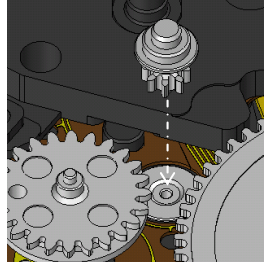
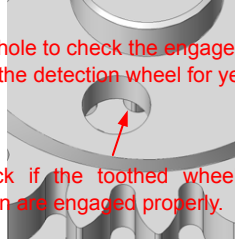
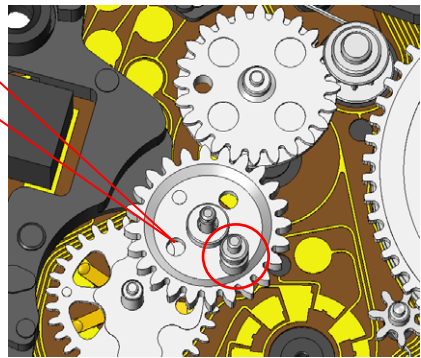
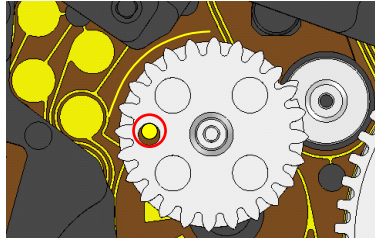
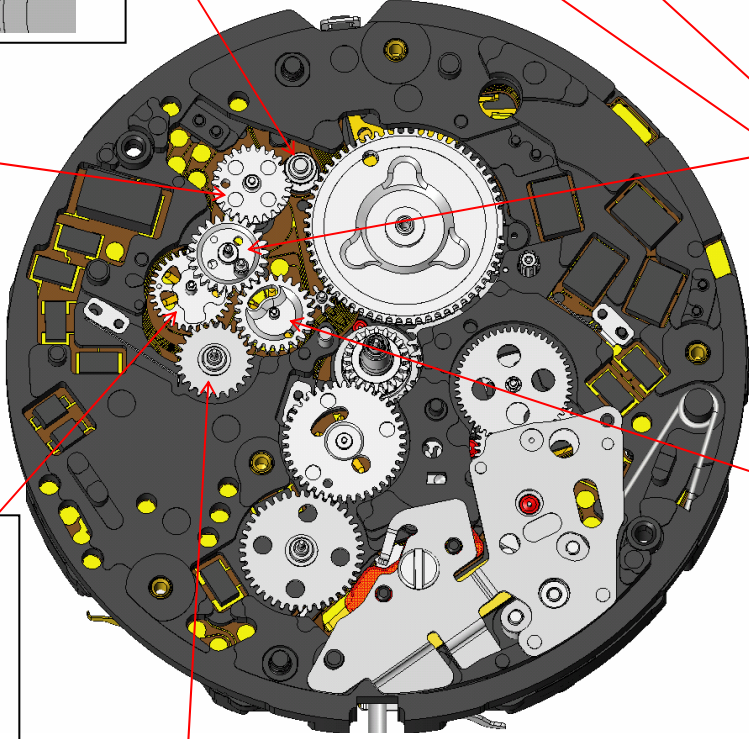
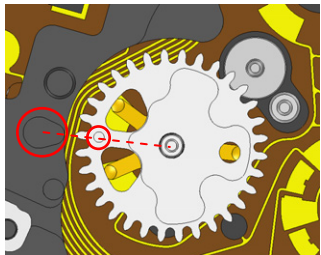
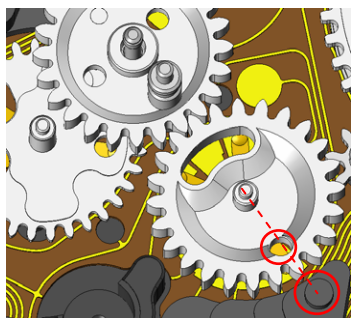
No.	PROCESS	ILLUSTRATIONS AND SPECIAL INSTRUCTIONS	
	Assembling the calendar wheels		
◆	Set the supporting pin for alignment.	<div data-bbox="405 236 797 783" style="border: 1px dashed black; padding: 5px;"> <p>Set the supporting pin for alignment.</p> <p>*Ensure that the supporting pin for alignment is set properly without any clearance. (The pin is reversible.)</p> <p>Note) You can install the calendar wheels without using the supporting pin.</p>  <p style="text-align: center;">Supporting pin</p> </div> <div data-bbox="831 225 1563 639" style="border: 1px solid black; padding: 5px;"> <p><22> Set the intermediate wheel for month indicator.</p> <p>*Ensure that the intermediate wheel for month indicator is put in the correct direction. (See the illustration below.)</p>  <p style="text-align: center;">Positioning pin</p> <p>*Set the intermediate wheel for month indicator from inside the spring (from the control wheel side). (See the illustration to the right.)</p> </div> <div data-bbox="1608 225 2159 536" style="border: 1px solid black; padding: 5px;"> <p><26> Align and set the control wheel and hook the control jumper.</p> <p>*Setting position: Align the hole of the control wheel and the hole of the control jumper. (See the red-circled part in the illustration below. Check if you can see the hole of the control jumper through the hole of the control wheel.)</p> <p>*Moving the hole of the jumper outwards to search the correct position to hook the jumper securely. (See the illustration below.)</p>  <p>Position of the jumper after it is fixed. Red-circled part</p>  <p style="text-align: center;">OK NG</p> </div> <div data-bbox="875 671 1570 1374" style="text-align: center;">  </div>	
26	Align and set the control wheel and hook the control jumper.		
25	Set the 2nd intermediate wheel for calendar.		
24	Set the detection on wheel for 24H.		
23	Set the indicator on wheel for 24H.	<div data-bbox="405 831 864 1461" style="border: 1px solid black; padding: 5px;"> <p><24> Set the detection on wheel for 24H.</p> <p>*To effectively test the detection of the 24H continuity, the detection on wheel for 24H should be mounted as shown below. (See the illustration.)</p> <p>The detection springs are positioned in front of the detection patterns.</p> <p>Detection patterns Detection springs</p>  <p style="text-align: right;">Detection on wheel for 24H Rotation direction</p> </div>	
22	Set the intermediate wheel for month indicator .		
		<p><23> Set the indicator on wheel for 24H.</p>	
		<p><25> Set the 2nd intermediate wheel for calendar.</p>  <p style="text-align: center;">Slide down</p>	

No.	PROSESS	ILLUSTRATIONS AND SPECIAL INSTRUCTIONS	
21	Set and align the driving wheel for year.	<p><20> Set the indicator wheel for year.</p> 	 <p>The hole to check the engagement with the detection wheel for year</p> <p>Check if the toothed wheel and pinion are engaged properly.</p>
	↓		
20	Set the indicator wheel for year.		
	↓		
19	Set and align the detection on wheel for year.		<p><18> Set and align the intermediate wheel for year indicator.</p> <p>*Set the hole of the toothed wheel (biggest hole) to the positioning pin to correctly align the intermediate wheel for year indicator. (If you do not use the positioning pin, align the hole of the toothed wheel (biggest hole) to the hole of the main plate.)</p> <p>*When mounting the intermediate wheel for year indicator, make sure that it is properly engaged with the driving wheel for year and detection wheel for year. Check that they are correctly aligned each other.</p> 
	↓		
18	Set and align the intermediate wheel for year indicator.	<p><21> Set and align the driving wheel for year.</p> <p>*Align the hole of the toothed wheel and the mark (indicator) on the circuit block for calendar. (See the illustration below.)</p> 	
	↓		
17	Set and align the detection on wheel for month.		
	↓		
16	Set the indicator on wheel for month.		
	↓		
	Check the alignments.		
		<p><19> Set and align the detection on wheel for year.</p> <p>*Align the mark of the toothed wheel and the mark of the circuit block spacer for calendar. (See the illustration below.)</p> 	
			<p><17> Set and align the detection on wheel for month.</p> <p>*Align the mark of the toothed wheel and the mark of the circuit block spacer for calendar. (See the illustration below.)</p> 
			<p><16> Set the indicator on wheel for month.</p>

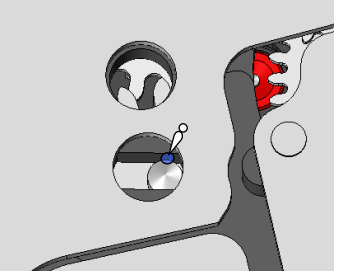
No.	PROSESS	ILLUSTRATIONS AND SPECIAL INSTRUCTIONS	
15	Set the train wheel bridge for calendar and check the pivot hole.	<p><15> Set the train wheel bridge for calendar and check the pivot hole.</p>	
	↓		
14	Tighten the train wheel bridge for calendar screw. (401#, 402#, 403#, 404#)	<p><14> Tighten the train wheel bridge for calendar screws. (410#, 402#, 403#, 404#)</p>	
	↓		
◆	Remove the supporting pin for alignment.	<p>◆ Remove the supporting pin for alignment</p>	
	↓		
◆	Remove the positioning pin for the spring for intermediate wheel for month indicator.	<p>◆ Remove the positioning pin for the spring for intermediate wheel for month indicator.</p>	
	↓		
	Lubricate the upper pivot of the 3rd intermediate wheel for calendar corrector.	<p><35> Set the jumper for month. *Rotate the jumper for month which has been tentatively set until it becomes engaged with the dowel. (See the illustration below.)</p>	
	↓	<p>Set the jumper for month.</p> 	
35	Set the jumper for month.		
	↓		
13	Set the jumper for year.		<p><13> Set the jumper for year. *Insert the tip of the jumper from an angle (1) and engage it with the dowel of the circuit block spacer for calendar while holding the jumper contacting the lateral surface of the axes of the indicator on wheel for year (2). (See the illustration below.) *Press the jumper straight down to securely engage it with the dowel without any clearance.</p> 
			<p>Lubricate the upper pivot of the 3rd intermediate wheel for calendar corrector. *Type of oil, oil quantity: A0-3II-1 (To prevent parts from wearing)</p> 

No.	PROSESS	ILLUSTRATIONS AND SPECIAL INSTRUCTIONS
12	Set the jumper for units digit .	<div data-bbox="761 494 1624 1348" data-label="Image"> </div> <div data-bbox="1657 255 2150 718" data-label="Text"> <p><12> Set the jumper for units digit.</p> <ul style="list-style-type: none"> *Set the jumper for units digit, keeping the jumper in contact with the lateral surface of the axes of the date driving wheel for units digit. (See 1 in the illustration below.) *Press the jumper straight down to securely engage it with the dowel of the circuit block spacer for calendar without any clearance. *After completing the setting of the jumper, make sure that date driving wheel for units digit is well set in position without any resistance or rebound resilience. (See 2 and 3 in the illustration below.) </div> <div data-bbox="1724 726 2139 1125" data-label="Image"> </div> <div data-bbox="1702 1157 1915 1412" data-label="Image"> </div> <div data-bbox="1915 1157 2139 1412" data-label="Image"> </div>

No.	PROCESS	ILLUSTRATIONS AND SPECIAL INSTRUCTIONS
11	Set the date dial for units digit and hook it.	<p><11> Set the date dial for units digit and hook it.</p> <p>*Set "1" to the 3 o'clock direction, and then align the notch of the date dial and hole of the train wheel bridge. (See the red-circled part in the illustration below.)</p>
10	Set the date dial for ten's digit .	<p><10> Set the date dial for ten's digit.</p> <p>*While moving "0" to the 3 o'clock direction, set the date dial for ten's digit to the pinion for ten's digit at an angle that the notch of the date dial and hole of the train wheel bridge are aligned (see the red-circled part in the illustration below) and then firmly press it down to secure. (See the blue-circled part in the illustration below.)</p>
9	Set the date dial holder for trans wheel for units digit .	<p><9> Set the date dial holder for trans wheel for units digit.</p> <p>*Set the patterned side up. (See the illustration to the left.)</p> <p>*Firmly press the down the point of engagement to securely set it in position.</p>
8	Set the indication disk for year. (for cal.7D48A only)	<p><8> Set the indication disk for year.</p> <p>*Align the notch at the "+1" side and the hole of the train wheel bridge, and then firmly press it down to secure. (See the red-circled part in the illustration below.)</p> <p>*The center of the notch should be within the range of the hole of the train wheel bridge. (See the blue-circled part in the illustration below.)</p>
		<div data-bbox="414 528 958 1070" data-label="Image"> </div> <div data-bbox="974 209 1601 662" data-label="Image"> </div> <div data-bbox="1624 209 2161 783" data-label="Image"> </div> <div data-bbox="974 687 1601 1342" data-label="Image"> </div> <div data-bbox="1624 783 2161 1326" data-label="Image"> </div> <div data-bbox="414 1086 974 1469" data-label="Text"> <p>◆ Remarks on handling the date dials</p> <p>*Extra attention must be paid when handling the date dials. Scratches or stains on the printed sides may cause malfunction.</p> <p>*When removing the date dial for ten's digit, insert the jig from the "2" direction of the date dial for ten's digit and from the directions other than the "6", "7", "8" or "9" of the date dial for units digit, and then remove the date dial for ten's digit. (To prevent any scratches to the backside, and damages to parts)</p> </div>

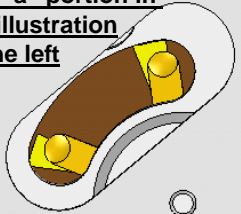
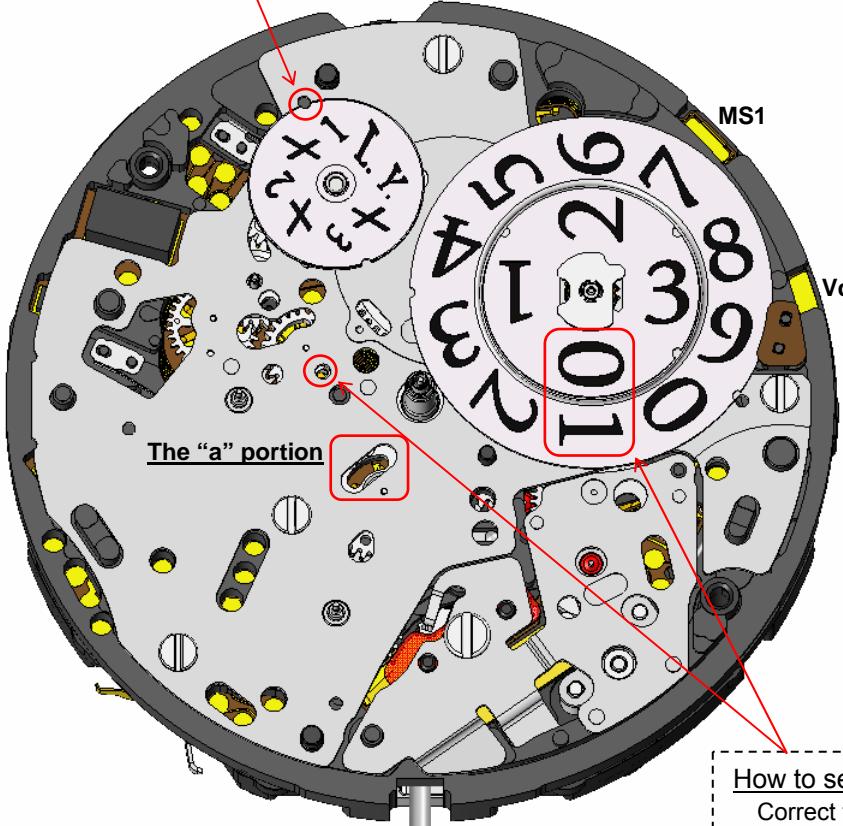
No.	PROSESS	ILLUSTRATIONS AND SPECIAL INSTRUCTIONS
	Check the movement of the hands. ↓	<div data-bbox="465 229 1211 376" style="border: 1px dashed black; padding: 5px;"> <p><u>How to set to a leap year</u> Check that the notch at the “+1” side and the hole of the train wheel bridge are aligned. If they are out of alignment, correct the calendar to adjust them.</p> </div>
	Check the detection of the 24 H contact point. ↓	<div data-bbox="1435 229 2159 357" style="border: 1px solid black; padding: 5px;"> <p>Check the movement of the hands. *The hands should move smoothly without dropping off while rotating or without any friction.</p> </div>
	Check the calendar correction. ↓	<div data-bbox="1435 384 2159 512" style="border: 1px solid black; padding: 5px;"> <p>Check the detection of the 24H contact point. *Move the hands clockwise to rotate the detection on wheel for 24H. Then verify the continuity between MS1 and Vdd.</p> </div>
	Reset the calendar to the default settings. ↓	<div data-bbox="1435 600 2159 855" style="border: 1px solid black; padding: 5px;"> <div data-bbox="1473 603 1688 692" style="border: 1px solid black; padding: 2px;"> <p>The “a” portion in the illustration to the left</p> </div> <div data-bbox="1473 600 1809 855" style="text-align: center;">  </div> <div data-bbox="1845 608 2136 703" style="padding-left: 20px;"> <p>The two springs for detection are on the pattern</p> </div> </div>
	Reset procedure	<div data-bbox="465 416 1339 1246" style="text-align: center;">  </div>
		<div data-bbox="1391 879 2159 1002" style="border: 1px solid black; padding: 5px;"> <p>Check the calendar correction. *Ensure that the calendar is corrected smoothly without any friction. *You will hear the click and the date should change smoothly.</p> </div>
		<div data-bbox="1391 1034 2159 1129" style="border: 1px solid black; padding: 5px;"> <p>Reset the calendar to the default settings. Reset procedure. *Set to a leap year, January 1. (See the illustration to the left.)</p> </div>
		<div data-bbox="1182 1166 1917 1390" style="border: 1px dashed black; padding: 5px;"> <p><u>How to set to January 1</u> Correct the calendar as below: 1 Align the hole of the detection on wheel for month and the hole of the train wheel bridge (January). 2 Read the date to the 3 o'clock direction to set “0” for ten's digit and “1” for units digit.</p> </div>

7D** Technical Instruction

No.	PROSESS	Specifications (Quality specifications, handling methods etc.)	ILLUSTRATIONS AND SPECIAL INSTRUCTIONS
	Assembling the case		<p>Set the movement. Check the positions of date, month and year. (Ensure it is set to a leap year, January 1.)</p> <div style="display: flex; justify-content: space-between;"> <div style="border: 1px solid red; padding: 2px; font-size: small;"> <p>Date The date should be positioned as shown in the illustration.</p> </div> <div style="border: 1px solid red; padding: 2px; font-size: small;"> <p>Month The hole of the detection on wheel for month and the hole of the train wheel bridge should be properly aligned.</p> </div> </div> <div style="border: 1px solid red; padding: 2px; font-size: small; margin-top: 10px;"> <p>Year The notch at the "+1" side and the hole of the train wheel bridge should be properly aligned.</p> </div> <p style="margin-top: 20px;">Rotation of the pins for dial fixing pins</p> <div style="display: flex; align-items: center; margin-top: 10px;"> Rotate <div style="margin-left: 20px; font-size: small;"> <p>Ensure that the pins for dial fixing are securely engaged with the dial without any clearance.</p> </div> </div>
		(for Cal. 7D48)	
	Set the movement.	Check the positions of date, month and year. (Ensure it is set to a leap year, January 1.) (See the illustration to the right.)	
	↓	(For Cal. 7D46, please refer to the illustration <21> Set and align the driving wheel for year indicator on the Page 21, when checking the position of leap year.)	
	Set the dial.	Holes for dial fixing pins: 15#, 16#	
	↓		
	Rotate the pins for dial fixing.	Ensure that the dial is securely mounted without any clearance. Rotate the eccentric pins clockwise to fix the legs of the dial.	
	Detect the 24 H connection.	Check the detection of the 24H contact point to adjust the timing of date change. -When doing this, turn the hands clockwise.	

