

No.	PROCESS	ILLUSTRATIONS AND SPECIAL INSTRUCTIONS ETC.	
	I) Assembling wheels to the oscillating bridge		
	Lubricate the oscillating weight bridge. Refer to the Fig. 2.		
	↓		
80	Mount the crown wheel to the axis of the oscillating weight bridge.		
	↓		
79	Fix the crown wheel by tightening the crown wheel fixing screw.		
	↓		
78	Insert the ratchet wheel.		
	↓		
(35)	Lubricate the switching wheel. Refer to the Fig. 3.		

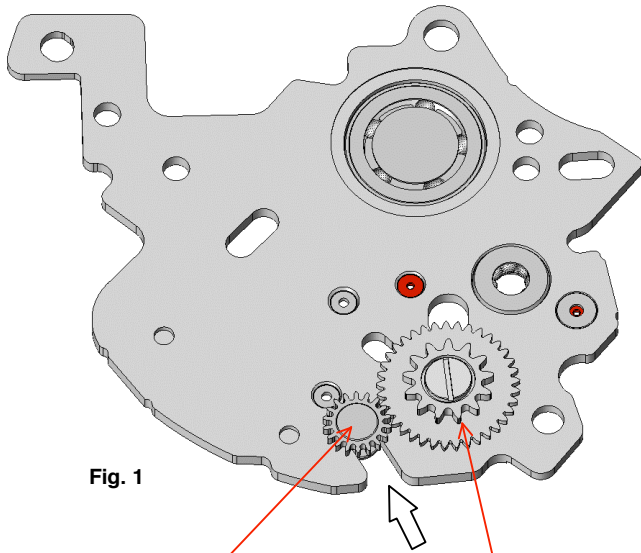

Fig. 1

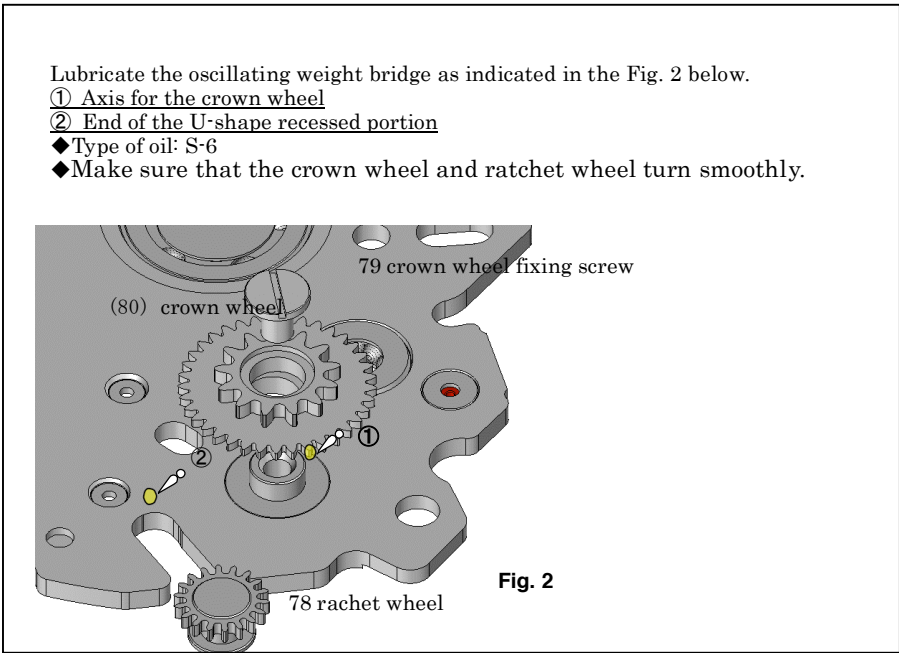

Fig. 2

<78> Insert the ratchet wheel.
 ◆ From the direction indicated by the arrow, insert the ratchet wheel to the end of the U-shape recessed portion of the oscillating weight bridge, where S-6 has been applied, and temporarily fix it by the viscosity of S-6.
 ◆ Make sure that the ratchet wheel smoothly moves without making creaking noises.

<80> Mount the crown wheel to the axis of the oscillating weight bridge.
 <79> Fix the crown wheel by tightening the crown wheel fixing screw.

(35) Lubricate the switching wheel as indicated in the Fig. 3 below.

① Side surface of the axis
 ◆ Type of oil: AO-3
 Note: Lubricate the same location twice.
 ◆ Apply the lubricant to the clearance underneath the teeth so that the lubricant is thoroughly applied to the side surface of the axis.

② Tip of the lug
 ◆ Type of oil: AO-3

③ Axis of the lug
 ◆ Type of oil: AO-3
 ◆ Apply the lubricant to the clearance around the axis so that the lubricant is applied to the entire surface of the axis.
 ◆ Ensure that an appropriate amount of oil is applied to the lower part of the axis, as excessive lubrication may cause malfunctions of the axis.

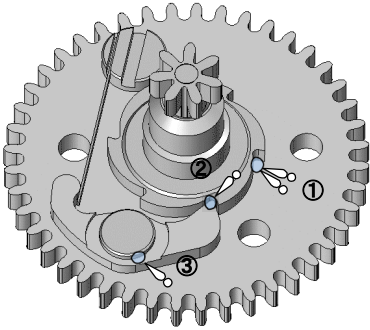
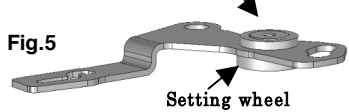
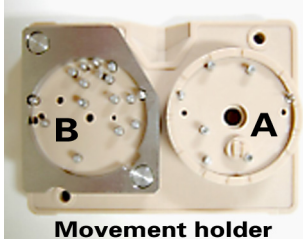
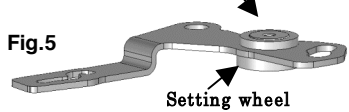
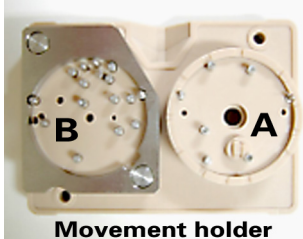
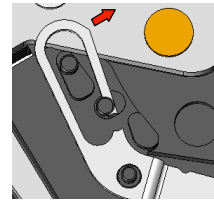

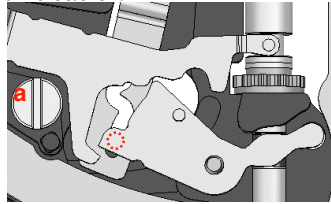
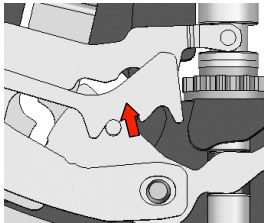
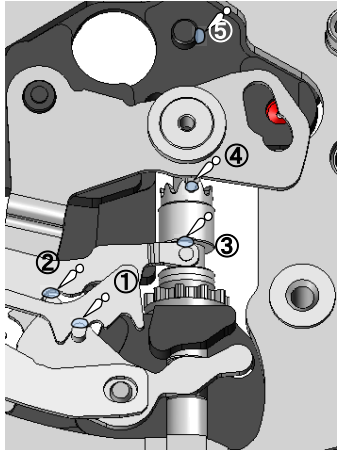
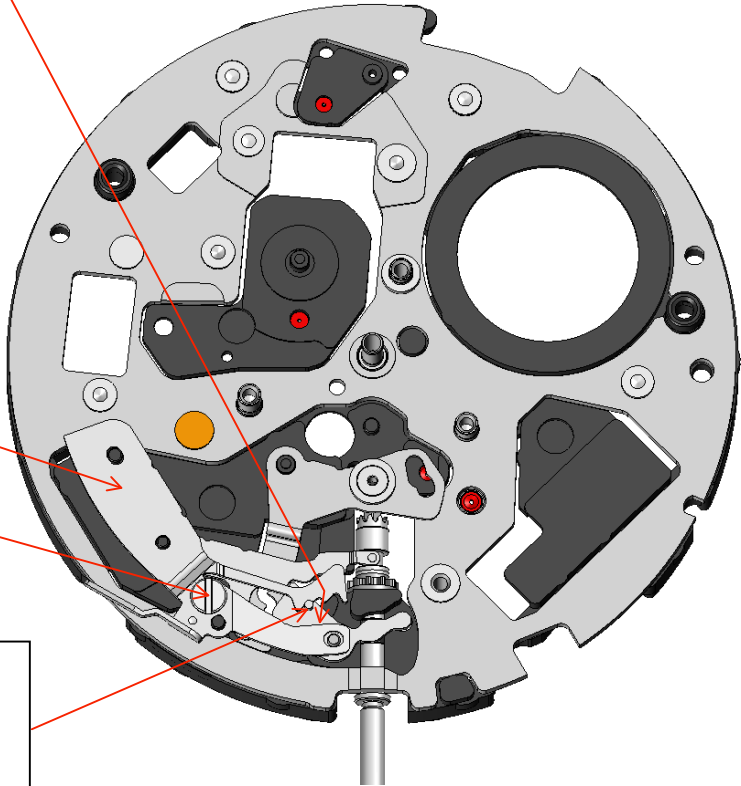

Fig. 3

No.	PROCESS	ILLUSTRATIONS AND SPECIAL INSTRUCTIONS ETC.
	<p>II) Assembling the dial side of the movement (1)</p>	<p><72> Mount the switching lever. ◆ Two wheels are attached to the switching lever as illustrated at right. Check if the switching lever has appropriate clearances with the intermediate wheel for calendar corrector and with the setting wheel so that they turn smoothly without making creaking noises.</p> <div style="text-align: right;"> <p>Intermediate wheel for calendar corrector</p>  <p>Fig.5 Setting wheel</p> </div>
77 & 76	<p>Put the circuit bridge on the A part of the movement holder for Cal. 5D series. (Refer to the photo.) And then, mount the main plate to the circuit bridge.</p>	<p><77&76> Put the circuit bridge on the A part of the movement holder for Cal. 5D series. (Refer to the photo below.) And then, mount the main plate to the circuit bridge.</p>  <p>Movement holder</p>
	↓	
(75)	<p>Lubricate the winding pinion. Refer to Figs. 6 & 7.</p>	
	↓	
(73)	<p>Lubricate the winding stem. Refer to Fig. 8.</p>	
	↓	
75,74 & 73	<p>Install the winding stem to the main plate with winding pinion and clutch wheel.</p>	<p><75,74 & 73> Install the winding stem to the main plate with winding pinion and clutch wheel.</p>
	<p>Lubricate the switching lever. Refer to the Fig. 9 & 10.</p>	<p><77> Lubricate the switching lever. ◆ Two wheels are attached to the switching lever as illustrated at right. Check if the switching lever has appropriate clearances with the intermediate wheel for calendar corrector and with the setting wheel so that they turn smoothly without making creaking noises.</p> <div style="text-align: right;"> <p>Intermediate wheel for calendar corrector</p>  <p>Fig.5 Setting wheel</p> </div>
72	<p>Mount the switching lever. (Check the clearance.) Refer to the Fig. 5.</p>	<p><77> Put the circuit bridge on the A part of the movement holder for Cal. 5D series. (Refer to the photo below.) And then, mount the main plate to the circuit bridge.</p>  <p>Movement holder</p>
71	<p>Mount the yoke, and securely hook its spring.</p>	<p><71> Mount the yoke, and securely hook its spring. ◆ Securely set the arm of the yoke inside the pin of the main plate, taking care so as not to deform the arm of the yoke.</p>  <p>Fig. 11</p>

No.	PROCESS	ILLUSTRATIONS AND SPECIAL INSTRUCTIONS ETC.
70	Mount the setting lever. Refer to the Fig.13.	<p><70>Mount the setting lever. ◆ Securely engage the pin on the backside of the setting lever (indicated by  in the Fig.13 below) with the guiding slit of the switching lever. Sliding the switching lever towards the “a” portion in the Fig. 13 will make this easier.</p>  <p style="text-align: right;">Fig.13</p>
	↓	
69	Place the setting lever spring. Refer to the Fig.12.	<p><69> Place the setting lever spring.</p>
	↓	
68	Fix the setting lever spring by tightening the setting lever screw. Refer to the Fig.12.	<p><68> Fix the setting lever spring by tightening the setting lever screw.</p>
	↓	
	Hook the arm of the setting lever. Refer to the Fig.14.	<p>Hook the arm of the setting lever. ◆ Do not push the setting lever excessively, as doing so may deform the arm of the setting lever.</p>  <p style="text-align: right;">Fig. 14</p>
	↓	
	Lubricate the yoke, setting lever and wheels. Refer to the Fig. 15.	<p>Lubricate the yoke, setting lever and wheels.</p> <p>① <u>Point of engagement between the yoke and setting lever spring</u> ② <u>Point of contact between the yoke and setting lever</u> ③ <u>Point of contact between the yoke and clutch wheel</u> ④ <u>Tips of the teeth of the clutch wheel (point of engagement between the clutch wheel and setting wheel)</u> ⑤ <u>Axis for the first intermediate minute wheel of the circuit bridge</u></p> <p>◆ Type of oil:AO-3</p>  <p style="text-align: right;">Fig. 15</p>
		<p><70>Mount the setting lever.</p>  <p style="text-align: right;">Fig. 12</p>

No.	PROCESS	ILLUSTRATIONS AND SPECIAL INSTRUCTIONS ETC.	
67	Mount the first intermediate minute wheel. Refer to Fig. 16.	<div data-bbox="421 323 1075 443" style="border: 1px solid black; padding: 5px;"> <p><66> Mount the anti-magnetic shield plate. ◆ Handle with care so as not to bend or deform it.</p> </div>	
66	Mount the anti-magnetic shield plate. Refer to Fig. 16.		
65	Mount the guide plate for date dial. Refer to Fig. 17.	<div data-bbox="1249 331 2123 475" style="border: 1px solid black; padding: 5px;"> <p><65> Mount the guide plate for date dial. ◆ Firmly press down the points of engagements (“a” and “b” portions) so that the guide plate for date dial is securely mounted.</p> </div>	
64	Fix the guide plate for date dial to the main plate by tightening the guide plate for date dial screw. Refer to Fig. 17.		
		<div data-bbox="421 1241 1102 1337" style="border: 1px solid black; padding: 5px;"> <p><67> Mount the first intermediate minute wheel. ◆ The first intermediate minute wheel is reversible.</p> </div>	<div data-bbox="1169 1265 1841 1361" style="border: 1px solid black; padding: 5px;"> <p><64> Fix the guide plate for date dial to the main plate by tightening the guide plate for date dial screw.</p> </div>

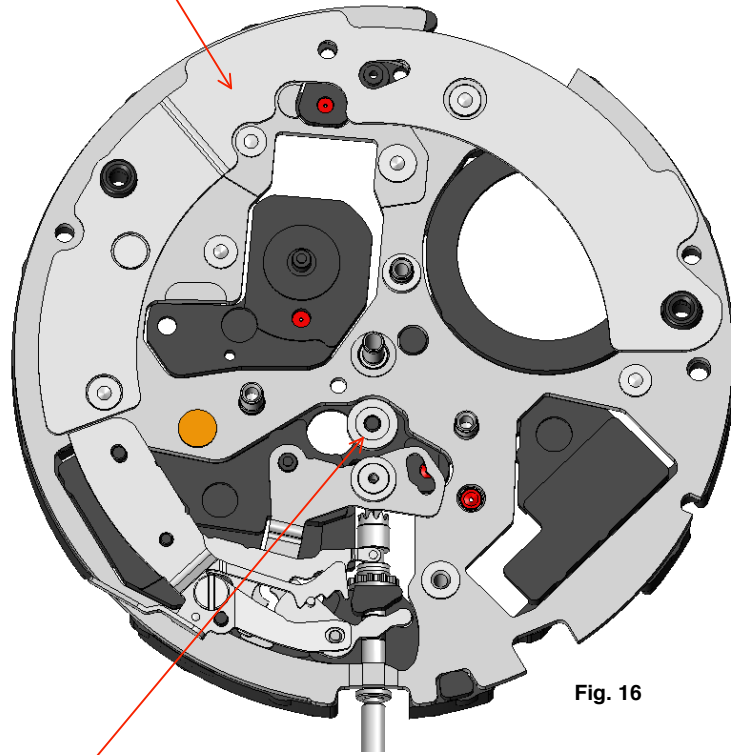

Fig. 16

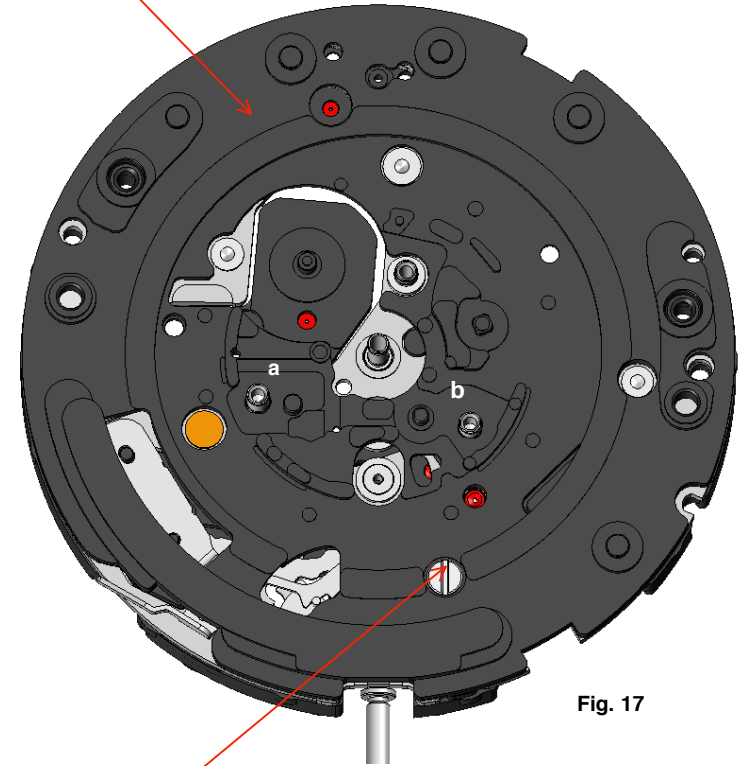
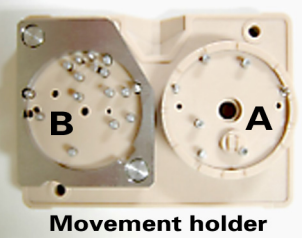
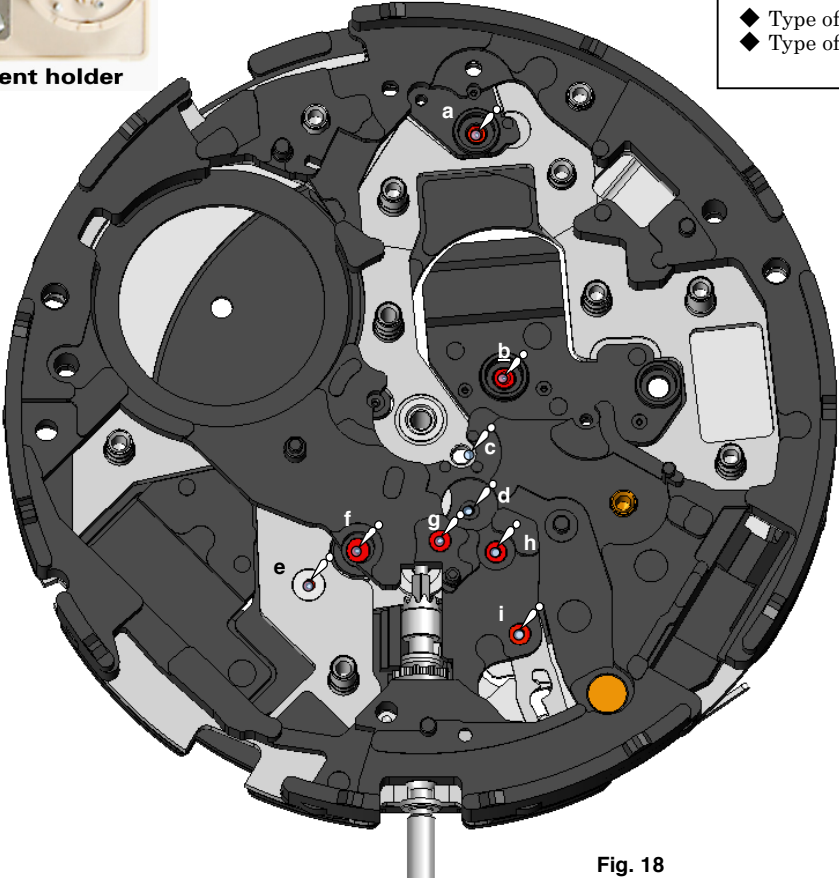
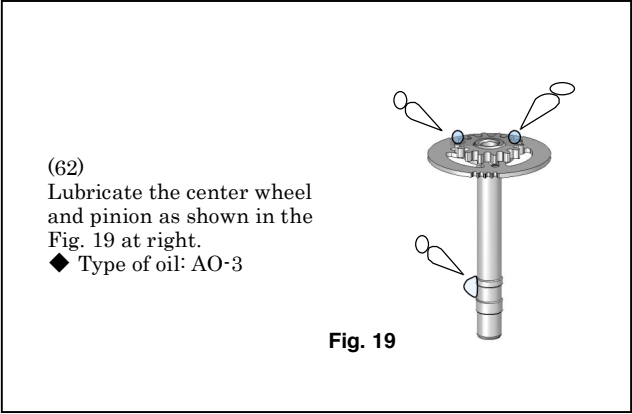

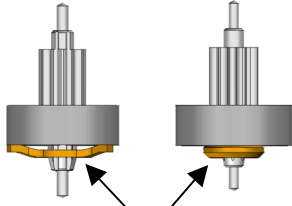



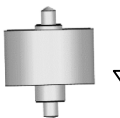
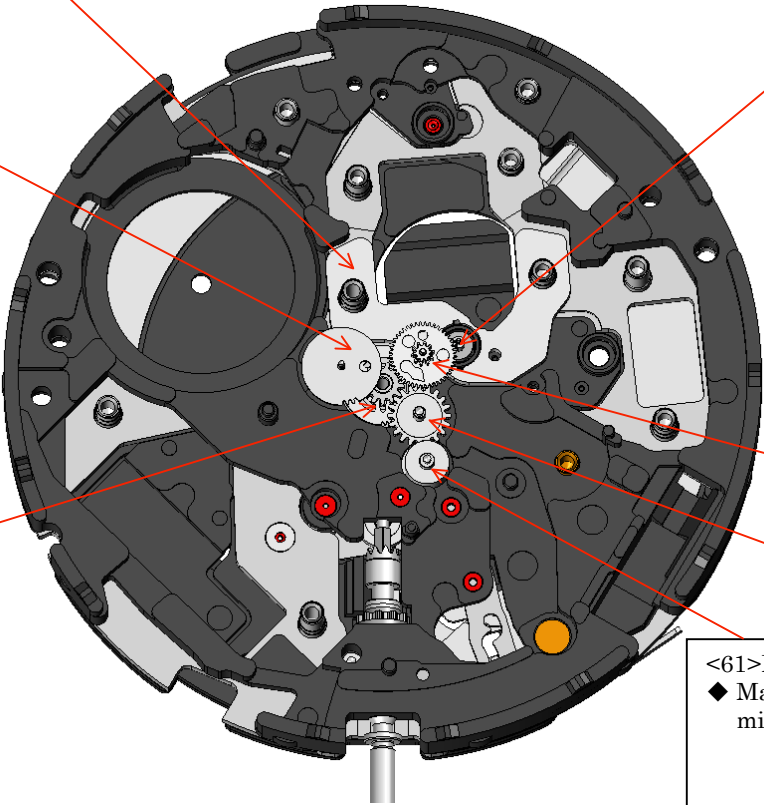

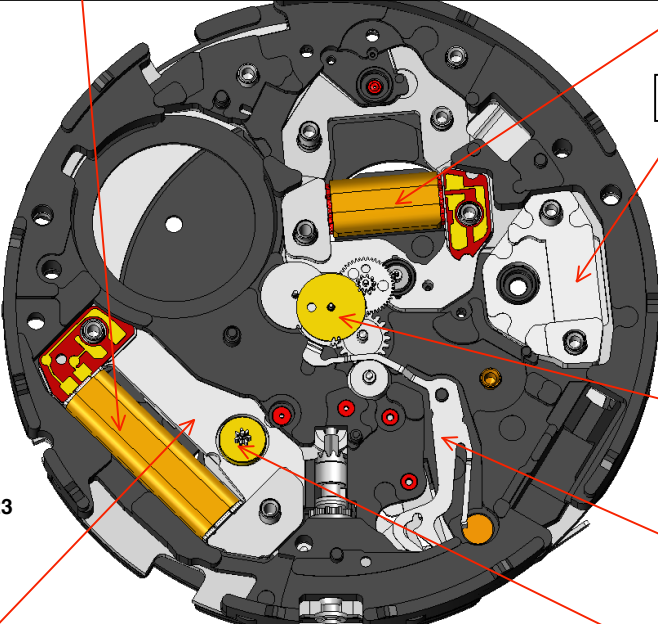
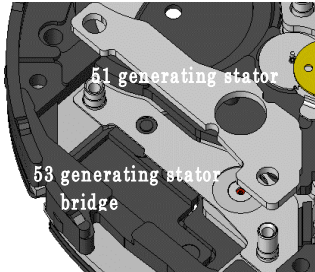
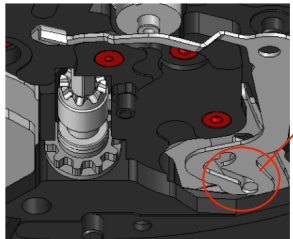
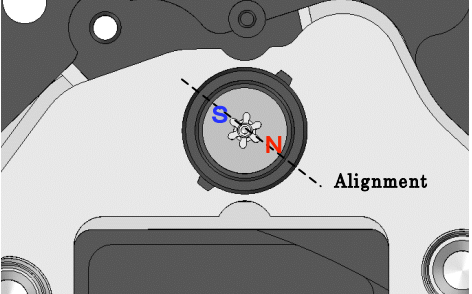
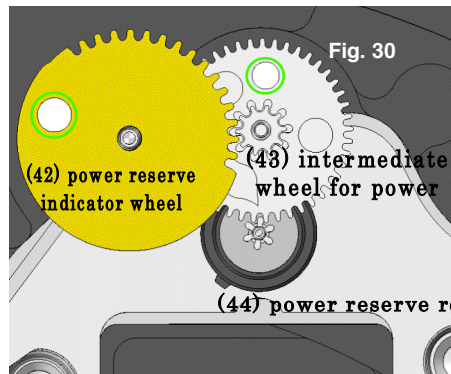
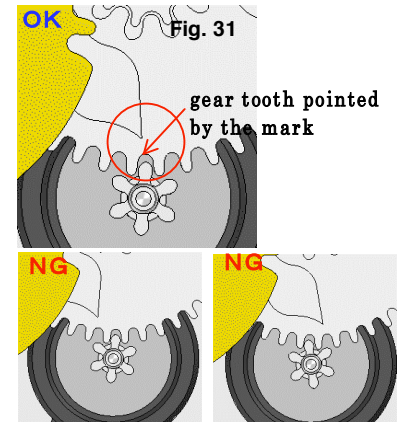
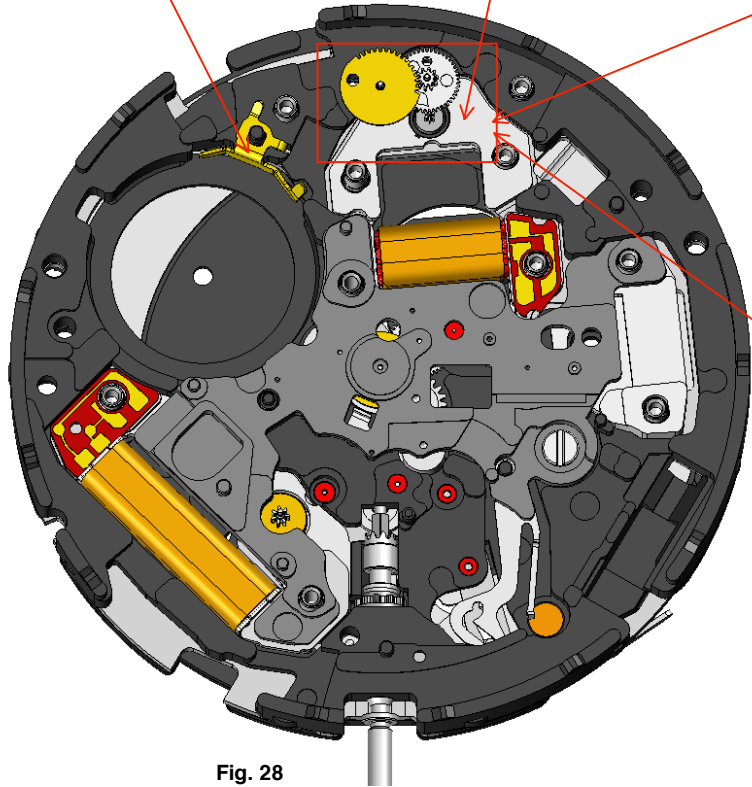

Fig. 17

No.	PROCESS	ILLUSTRATIONS AND SPECIAL INSTRUCTIONS ETC.
	<p>III) Assembling the case back side of the movement</p>	 <p>Movement holder</p>
	<p>Put the main plate upside down onto the B part of the movement holder. Refer to the photo.</p> <p style="text-align: center;">↓</p>	<p>Lubricate the lower pivots of the wheels from "a" to "i" shown in the Fig. 18 at left.</p> <ul style="list-style-type: none"> ◆ Type of oil for "a" and "b": AO-2 ◆ Type of oil from "c" to "i": AO-3
(62)	<p>Lubricate the center wheel and pinion. Refer to the Fig. 19.</p>	 <p style="text-align: center;">Fig. 18</p>
		 <p>(62) Lubricate the center wheel and pinion as shown in the Fig. 19 at right.</p> <ul style="list-style-type: none"> ◆ Type of oil: AO-3 <p style="text-align: center;">Fig. 19</p>

No.	PROCESS	ILLUSTRATIONS AND SPECIAL INSTRUCTIONS ETC.
63	Mount the rotor stator.	<div data-bbox="421 260 846 424" style="border: 1px solid black; padding: 5px;"> <p><63> Mount the rotor stator. ◆ When mounting the rotor stator, take care so as not to distort or deform it, as it may cause deterioration of the motor.</p> </div>
	↓	
62	Mount the center wheel and pinion.	
	↓	
61	Mount the second intermediate minute wheel. Refer to the Fig. 22.	<div data-bbox="421 547 846 667" style="border: 1px solid black; padding: 5px;"> <p><57> Mount the third wheel and pinion.</p> </div>
	↓	
60	Mount the minute wheel.	
	↓	
59	Mount the rotor. Refer to the Fig. 21.	<div data-bbox="1659 233 2148 834" style="border: 1px solid black; padding: 5px;"> <p><59> Mount the rotor. ◆ Do not mount the power reserve rotor by mistake. To discriminate the rotor from the power reserve rotor, see the difference in the shapes of their rotor bridges.</p> <div style="display: flex; justify-content: space-around; align-items: center;"> <div style="text-align: center;">  (59 Rotor) </div> <div style="text-align: center;">  (44 Power reserve rotor) </div> </div> <div style="display: flex; justify-content: center; align-items: center; margin-top: 10px;">  </div> <p style="text-align: center; margin-top: 5px;">rotor bridge Fig. 21</p> </div>
	↓	
58	Mount the fifth wheel and pinion.	<div data-bbox="1688 858 2148 941" style="border: 1px solid black; padding: 5px;"> <p><58> Mount the fifth wheel and pinion.</p> </div>
	↓	
57	Mount the third wheel and pinion.	<div data-bbox="421 914 846 1026" style="border: 1px solid black; padding: 5px;"> <p><62> Mount the center wheel and pinion.</p> </div>
	↓	
		<div data-bbox="1547 1050 2170 1461" style="border: 1px solid black; padding: 5px;"> <p><61>Mount the second intermediate minute wheel. ◆ Make sure to mount the second intermediate minute wheel in the correct direction.</p> <div style="display: flex; justify-content: space-around; align-items: center;"> <div style="text-align: center;">   </div> <div style="text-align: center;">   </div> </div> <p style="text-align: center; margin-top: 5px;">Fig. 22</p> </div>
		<div data-bbox="864 411 1626 1219" style="text-align: center;">  <p>Fig. 20</p> </div>

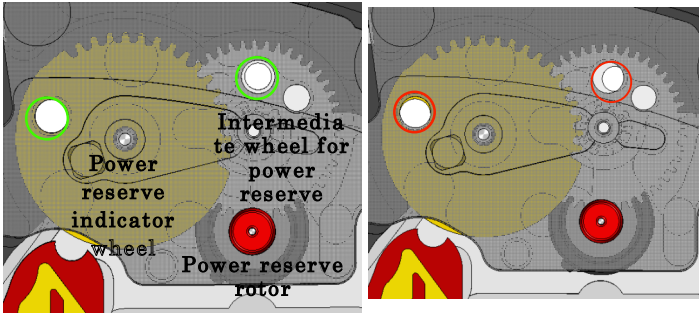
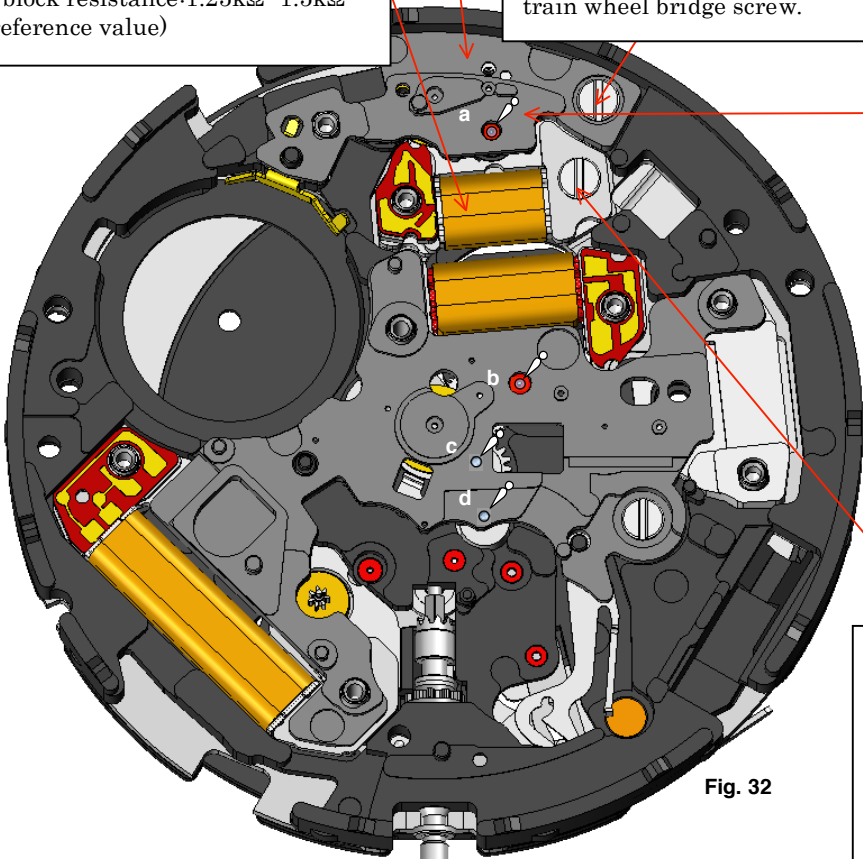
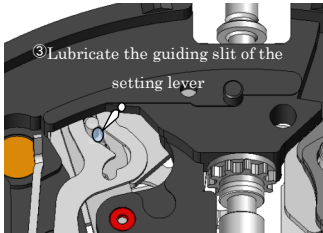

No.	PROCESS	ILLUSTRATIONS AND SPECIAL INSTRUCTIONS ETC.
56	Lubricate and set the fourth wheel, and pinion. Refer to the Fig. 25.	<div data-bbox="409 204 1182 352" style="border: 1px solid black; padding: 5px;"> <p><50> Mount the generating coil block. ◆ When mounting the generating coil block, take care so as not to distort or deform the coil block core as it may cause deterioration of the motor. * Coil block resistance between 585Ω and 645Ω (as reference value)</p> </div> <div data-bbox="1435 204 2119 400" style="border: 1px solid black; padding: 5px;"> <p><54> Mount the coil block. ◆ When mounting the coil block, take care so as not to distort or deform the coil block core as it may cause deterioration of the motor. * Coil block resistance between 1.9kΩ and 2.15kΩ (as reference value)</p> </div>
	↓	
55	Mount the train wheel setting lever. Refer to the Fig. 26.	
	↓	
54	Mount the coil block.	
	↓	
53	Mount the generating stator bridge. Refer to the Fig. 24.	
	↓	
52	Mount the generating stator. Refer to the Fig. 24.	
	↓	
51	Mount the generating rotor.	
	↓	
50	Mount the generating coil block.	
	↓	
49	Mount the circuit block spacer.	
	↓	
		<div data-bbox="1167 427 1630 475" style="border: 1px solid black; padding: 5px;"> <p><49> Mount the circuit block spacer.</p> </div> <div data-bbox="1205 496 1839 884" style="border: 1px solid black; padding: 5px;"> <p><56> Lubricate and set the fourth wheel and pinion. ◆ Type of oil: AO-3</p>  <p style="text-align: right;">Fig. 25</p> </div>
		<div data-bbox="456 847 533 874" style="text-align: left;"> <p>Fig. 23</p> </div> 
		<div data-bbox="409 979 1084 1437" style="border: 1px solid black; padding: 5px;"> <p><53> Mount the generating stator bridge. <52> Mount the generating stator. ◆ When mounting the generating stator bridge and generating stator, take care so as not to distort or deform the coil block core as it may cause deterioration of the motor.</p>  <p style="text-align: right;">Fig. 24</p> </div> <div data-bbox="1115 979 1285 1123" style="border: 1px solid black; padding: 5px;"> <p><51> Mount the generating rotor.</p> </div>
		<div data-bbox="1323 954 2069 1433" style="border: 1px solid black; padding: 5px;"> <p><55> Mount the train wheel setting lever. ◆ Insert the tail portion of the train wheel setting lever with the guiding slit at an angle into the gap of the circuit bridge, and securely set the guiding slit to the dowel pin of the setting lever.</p>  <p style="text-align: right;">Fig. 26</p> </div>

No.	PROCESS	ILLUSTRATIONS AND SPECIAL INSTRUCTIONS ETC.
46	Mount the secondary battery connection (+).	<div data-bbox="421 231 1131 279" style="border: 1px solid black; padding: 2px;"> <46> Mount the secondary battery connection (+). </div>
	↓	
45	Mount the power reserve stator.	<div data-bbox="683 303 1198 351" style="border: 1px solid black; padding: 2px;"> <45>Mount the power reserve stator. </div>
	↓	
44	Mount the power reserve rotor. Refer to the Fig. 29 for the alignment of the power reserve rotor.	<div data-bbox="1355 207 2161 662" style="border: 1px solid black; padding: 5px;"> <44>Mount the power reserve rotor. ◆ Make sure that the magnetic polarities (positive and negative) of the power reserve rotor are aligned as illustrated below. * The built-in magnets of the movement holder will magnetically correct the alignment of the power reserve rotor. <div data-bbox="1624 359 2094 654" style="text-align: center;">  <p>Alignment</p> </div> <p>Fig. 29</p> </div>
	↓	
43	Mount the intermediate wheel for power reserve. Refer to the Figs. 30 & 31 for the alignment of the intermediate wheel for power reserve.	<div data-bbox="1220 686 2161 1476" style="border: 1px solid black; padding: 5px;"> <43>Mount the intermediate wheel for power reserve. (Alignment check) <42>Mount the power reserve indicator wheel. (Alignment check) ◆ Set the aligning holes (indicated by ○ in the illustration below) on the surface of the wheels to the positions corresponding to the aligning pins on the movement holder. (Refer to the Fig. 30 below.) ◆ After setting the intermediate wheel for power reserve, tilt the power reserve rotor towards the intermediate wheel for power reserve. Make sure that the gear tooth pointed by the mark on the intermediate wheel for power reserve is securely engaged with a gear tooth of the pinion of the power reserve rotor. (Refer to the Fig. 31 below.) <div data-bbox="1243 1085 1691 1460" style="text-align: center;">  <p>Fig. 30</p> <p>(42) power reserve indicator wheel</p> <p>(43) intermediate wheel for power</p> <p>(44) power reserve rotor</p> </div> <div data-bbox="1736 1037 2139 1460" style="text-align: center;">  <p>Fig. 31</p> <p>OK</p> <p>gear tooth pointed by the mark</p> <p>NG</p> <p>NG</p> </div> </div>
42	Mount the power reserve indicator wheel. Refer to the Figs. 30 & 31 for the alignment of the power reserve indicator wheel.	<div data-bbox="459 422 1209 1212" style="text-align: center;">  <p>Fig. 28</p> </div>
	↓	

No.	PROCESS	ILLUSTRATIONS AND SPECIAL INSTRUCTIONS ETC.
	Change the movement holder to an universal holder (S-682).	
41	Mount the power reserve train wheel bridge and check the pivot hole.	<p data-bbox="465 220 936 272"><39> Mount the power reserve coil block.</p> <p data-bbox="465 272 936 389">◆ When mounting the power reserve coil block, take care so as not to distort or deform the coil block core as it may cause deterioration of the motor. Coil block resistance:1.25kΩ -1.5kΩ (as reference value)</p> <p data-bbox="965 220 1413 272"><41> Mount the power reserve train wheel bridge and check the pivot hole.</p> <p data-bbox="1055 331 1413 389"><40> Fix the power reserve train wheel bridge by tightening the power reserve train wheel bridge screw.</p>
	↓	
40	Fix the power reserve train wheel bridge by tightening the power reserve train wheel bridge screw.	<p data-bbox="1451 220 2170 304">Check the alignment of the power reserve indicator (42) and the intermediate wheel for power reserve (43) through the holes of the train wheel bridge (41).</p> <p data-bbox="1451 331 2170 464">Make sure that the positions of the holes on the power reserve train wheel bridge (indicated by ○ in the illustration below) are strictly corresponded to the positions of the holes on the intermediate wheel for power reserve and power reserve indicator wheel.</p> <p data-bbox="1771 464 2170 571">Bad example: The intermediate wheel for power reserve and the power reserve rotor are not correctly engaged.</p> <p data-bbox="1464 517 1541 539">Fig. 33</p> 
	↓	
	Lubricate the upper pivots of the wheels.(“a”, “b”, “c” and “d” portions) Refer to the Fig. 32.	 <p data-bbox="1240 1209 1317 1232">Fig. 32</p>
	Lubricate the guiding slit of the setting lever. Refer to the Fig. 34.	
	↓	
39	Mount the power reserve coil block.	
	↓	<p data-bbox="1451 986 2170 1038"><38> Fix the power reserve coil block by tightening the power reserve coil block screw.</p>
38	Fix the power reserve coil block by tightening the power reserve coil block screw.	<p data-bbox="1406 1075 2170 1128">Lubricate the guiding slit of the setting lever: refer to the Fig. 34 below.</p> <p data-bbox="1406 1134 1615 1157">◆Type of oil:AO-3</p>  <p data-bbox="1935 1374 2011 1396">Fig. 34</p>
	↓	
	Check the alignment of the power reserve indicator (42) and the intermediate wheel for power reserve (43) through the holes of the train wheel bridge (41).	<p data-bbox="465 1331 936 1353">Lubricate the upper pivots of the wheels.</p> <p data-bbox="465 1359 936 1382">① “a” and “b” portions ◆Type of oil:AO-2</p> <p data-bbox="465 1388 936 1410">② “c” and “d” portions ◆Type of oil:AO-3</p>

No.	PROCESS	ILLUSTRATIONS AND SPECIAL INSTRUCTIONS ETC.
37	Mount the first intermediate wheel for manual winding.	<div data-bbox="430 277 864 363" style="border: 1px solid black; padding: 5px; width: fit-content;"> <35> Mount the switching wheel. </div> <div data-bbox="1155 220 2123 376" style="border: 1px solid black; padding: 5px; width: fit-content;"> <36>Mount the circuit block. ◆Firmly press down the points of engagements (six points from “a” to “f” indicated by ○ in the Fig. 35). </div>
36	Mount the circuit block.	
35	Mount the switching wheel.	
34	Mount the third intermediate wheel for manual winding.	
33	Mount the second intermediate wheel for manual winding.	
		<div data-bbox="539 352 1361 1187" style="text-align: center;"> </div> <div data-bbox="1397 916 1480 943" style="text-align: right;"> Fig. 35 </div> <div data-bbox="1189 1094 2024 1171" style="border: 1px solid black; padding: 5px; width: fit-content; margin: 10px auto;"> <37>Mount the first intermediate wheel for manual winding. </div> <div data-bbox="987 1190 2024 1267" style="border: 1px solid black; padding: 5px; width: fit-content; margin: 10px auto;"> <33>Mount the second intermediate wheel for manual winding. </div> <div data-bbox="430 1294 1379 1377" style="border: 1px solid black; padding: 5px; width: fit-content; margin: 10px auto;"> <34>Mount the third intermediate wheel for manual winding. </div>

No.	PROCESS	ILLUSTRATIONS AND SPECIAL INSTRUCTIONS ETC.
32	Mount the circuit block cover C.	
	↓	
31	Mount the circuit block cover A.	
	↓	
30	Mount the circuit block cover B.	
29	Mount the oscillating weight bridge in process I and check the pivot hole. Refer to the Fig. 38.	
	↓	
28&27	Fix the oscillating weight bridge and circuit block cover B by tightening the screws from "a" to "e". Refer to the Fig. 37.	
	Check if there is an adequate clearance to allow vertical movement of the wheels underneath the oscillating weight bridge.	

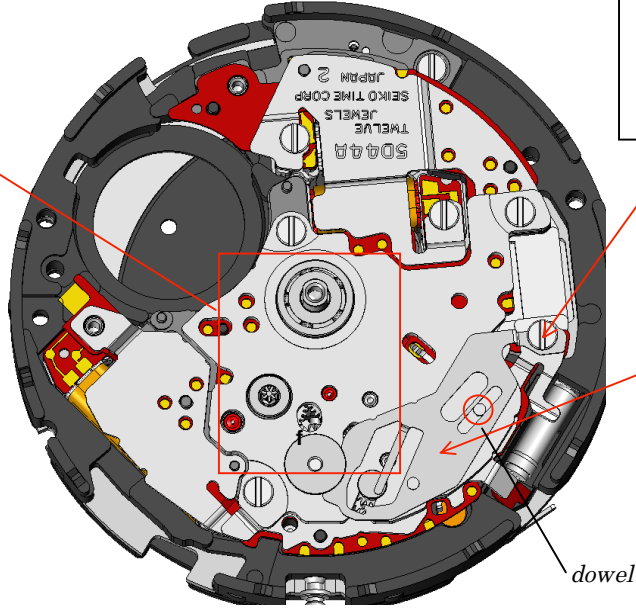
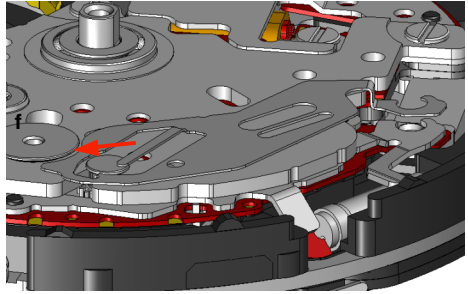
No.	PROCESS	ILLUSTRATIONS AND SPECIAL INSTRUCTIONS ETC.
	Lubricate the upper pivots of the wheels for manual winding mechanism at the "a" to "e" portions as shown in the Fig. 40.	<p>Lubricate the upper pivots of the wheels for manual winding mechanism at the "a" to "e" portions as shown in the Fig. 40.</p> <p>◆ Type of oil:AO-3</p>  <p>Fig. 40</p>
	Lubricate the bearings of the wheels as shown in the Fig. 40.	
26	Insert the friction spring for ratchet wheel beneath the "f" portion shown in the Fig. 41.	<p><26> Insert the friction spring for ratchet wheel beneath the "f" portion shown in the Fig. 41 below.</p> <p>◆ Firmly press the  down to securely engage it with the dowel indicated in the Fig. 39 at left, so that it is mounted without any clearance between the friction spring for ratchet wheel and the oscillating weight bridge.</p>
25	Fix the circuit block cover A (31) and the friction spring for ratchet wheel (26) by tightening the friction spring for ratchet wheel screw.	<p><25> Fix the circuit block cover A (31) and the friction spring for ratchet wheel (26) by tightening the friction spring for ratchet wheel screw.</p>  <p>Fig. 39</p>  <p>Fig. 41</p>
	Check the current consumption after setting the secondary battery unit temporarily. Refer to the page 39.	<p>Lubricate the bearings of the wheels as shown in the Fig. 40 above.</p> <p>◆ Type of oil:AO-3</p>

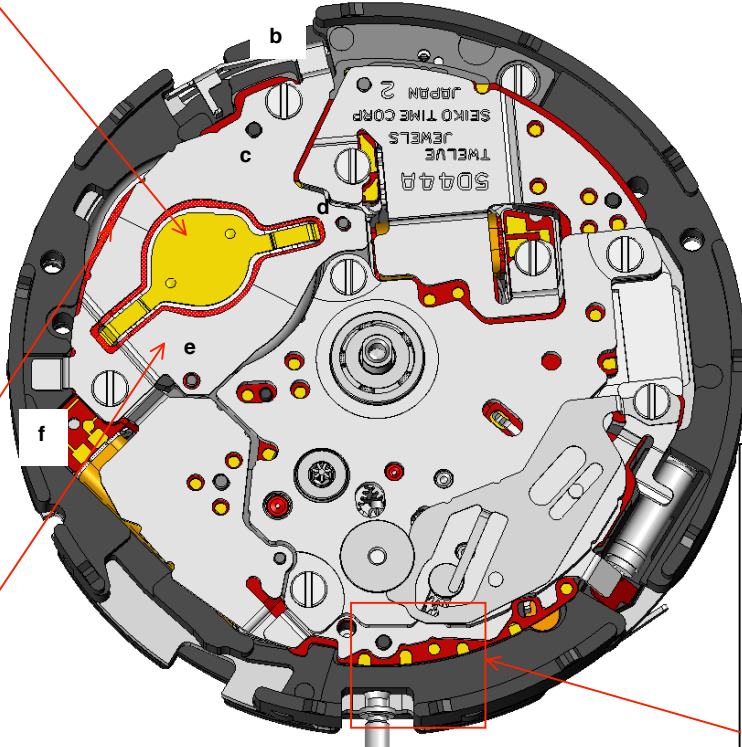
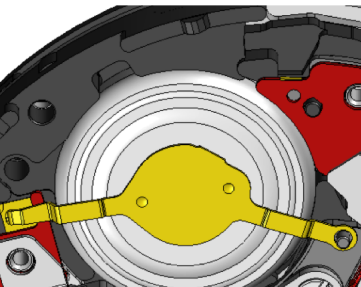
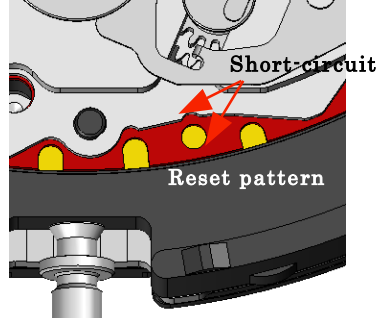
No.	PROCESS	ILLUSTRATIONS AND SPECIAL INSTRUCTIONS ETC.
24	Mount the secondary battery unit. ↓	<p><24> Mount the secondary battery unit.</p> <ul style="list-style-type: none"> ◆ Hook the arm of the secondary battery unit to the “a” portion in the Fig. 43 below. ◆ Take care so as not to deform the minus terminal when removing the secondary battery unit.
23	Mount the insulator for secondary battery. ↓	<p><23>Mount the insulator for secondary battery.</p> <ul style="list-style-type: none"> ◆ Firmly press down the hole of the insulator for secondary battery to the guide tube of the main plate (“e”), then press down the point of engagement “d” until insulator for secondary battery is securely set in position.
22	Mount the secondary battery guard. ↓	<p><22>Mount the secondary battery guard.</p> <ul style="list-style-type: none"> ◆ Firmly press down the points of engagement to securely set it in position. • Positioning guide tube: “e” • Points of engagement: “c” and “d”
21	Fix the insulator for secondary battery and secondary battery guard by tightening the secondary battery guard screws “b” and “f”.	<p><21> Fix the insulator for secondary battery and secondary battery guard by tightening the secondary battery guard screws “b” and “f”.</p>
	Reset the built in IC. Refer to the Fig. 44.	<p>Reset the built in IC.</p> <ul style="list-style-type: none"> ◆ Short-circuit the built-in IC by connecting the reset pattern on the circuit block and the circuit block cover A using a pair of tweezers for approximately 2 seconds.
		 <p>Fig. 42</p>  <p>Fig. 43</p>  <p>Fig. 44</p>

No.	PROCESS	ILLUSTRATIONS AND SPECIAL INSTRUCTIONS ETC.
20	Lubricate and set the oscillating weight wheel. Refer to the Fig. 46.	<p><20> Lubricate and set the oscillating weight wheel as shown in the Fig. 46.</p> <p><u>① Spring portion</u></p> <ul style="list-style-type: none"> ◆ Type of oil: AO-3 ◆ Apply the lubricant to the clearance around the tip of the spring so that the lubricant is applied to the entire surface. <p><u>② Axis/oscillating portion of the wheel</u></p> <ul style="list-style-type: none"> ◆ Type of oil: AO-3 ◆ Apply the lubricant to the clearance around the indentation so that the lubricant is applied entirely to the inside surface of the axis.
	↓	
19	Mount the oscillating weight.	<p><19> Mount the oscillating weight.</p>
	↓	
18	Fix the oscillating weight by tightening the oscillating weight screw.	<p><18> Fix the oscillating weight by tightening the oscillating weight screw.</p>
	↓	
	Check the power generating performance.	<p>Check the movement of the oscillating weight.</p> <ul style="list-style-type: none"> ◆ Ensure that the oscillating weight rotates smoothly without any friction or resistance.
	↓	
	Check the movement of the oscillating weight.	<p>Check the movement of the crown by winding it clockwise at its normal position.</p> <ul style="list-style-type: none"> ◆ Make sure that the crown does not run idle and that it rotates smoothly without any resistance. ◆ The crown should rotate without making creaking noises. * If the generating rotor is not appropriately lubricated, you will hear the creaking (high-pitch sound).
	↓	
	Check the movement of the crown.	<p>Check the power generating performance</p> <p><u>① Check if the power is generated while the oscillating weight is rotating</u></p> <ul style="list-style-type: none"> ◆ Range of the initial voltage: between 1.30V and 1.55V ◆ The increase in voltage after spinning the oscillating weight should not be less than 50 mV. <p><u>② Check if the power is generated while the winding stem is rotating</u></p> <ul style="list-style-type: none"> ◆ The increase in voltage after rotating the winding stem weight should not be less than 50 mV.

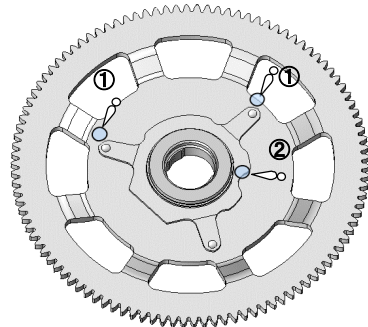

Fig. 46

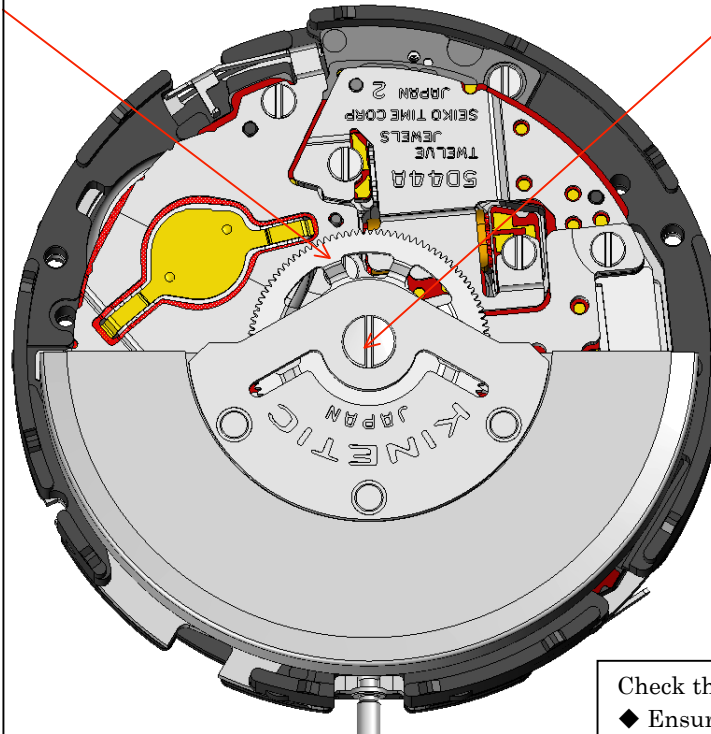

Fig. 45

Check the movement of the oscillating weight.

- ◆ Ensure that the oscillating weight rotates smoothly without any friction or resistance.

Check the movement of the crown by winding it clockwise at its normal position.

- ◆ Make sure that the crown does not run idle and that it rotates smoothly without any resistance.
- ◆ The crown should rotate without making creaking noises.
- * If the generating rotor is not appropriately lubricated, you will hear the creaking (high-pitch sound).

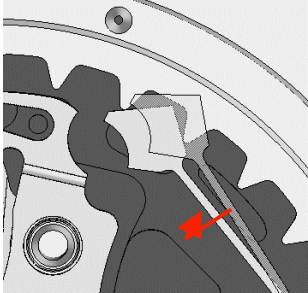
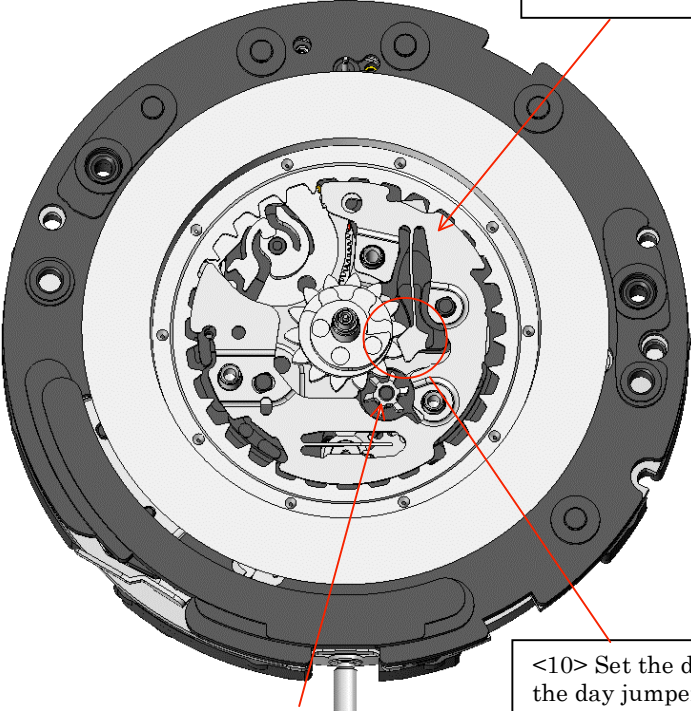
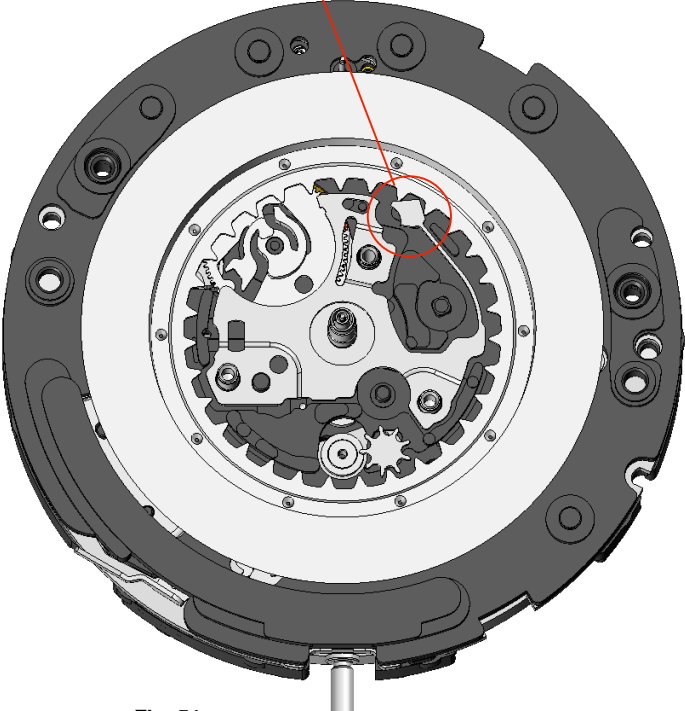
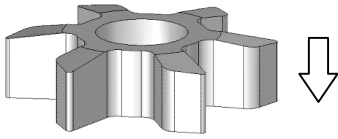
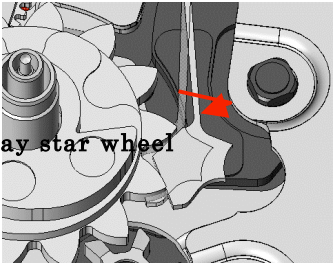

No.	PROCESS	ILLUSTRATIONS AND SPECIAL INSTRUCTIONS ETC.
	<p>IV)Assembling the dial side of the movement (2)</p>	
	<p>Set the movement upside down on the universal movement holder.</p>	
	<p>↓</p>	
17	<p>Mount the hour wheel.</p>	<p><17> Mount the hour wheel.</p>
	<p>↓</p>	
16	<p>Mount the dial washer. Refer to the Fig. 50.</p>	<p><15> Mount the date driving wheel. ◆Position the date driving wheel as shown in the Fig. 47 to avoid any friction after assembling the date dial and day star wheel.</p>
	<p>↓</p>	
15	<p>Mount the date driving wheel. Refer to the Fig. 47.</p>	<p>Lubricate the oscillating hole for the date corrector wheel. Refer to the Fig. 48.</p>
	<p>↓</p>	
14	<p>Mount the date corrector wheel after lubricating the oscillating hole.</p>	<p><13>Mount the date dial. <14> Mount the date corrector wheel.</p>
	<p>↓</p>	
13	<p>Mount the date dial.</p>	<p><16>Mount the dial washer.</p>
	<p>↓</p>	
		<p>◆Make sure the dial washer is put in the correct direction. (See the Fig. 51 below.)</p>
		<p>◆When mounting the dial washer, handle it with care so as not to bend or deform it.</p>
		<p>Fig. 47</p>
		<p>Fig. 48</p>
		<p>Fig. 49</p>
		<p>Fig. 50</p>

No.	PROCESS	ILLUSTRATIONS AND SPECIAL INSTRUCTIONS ETC.
12	Set and hook the date jumper to the date dial. Refer to the Fig. 53.	<p data-bbox="427 256 931 336"><12>Set and hook the date jumper to the date dial. ◆Take care so as not to deform it.</p>  <p data-bbox="813 584 882 608">Fig. 53</p>
11	Mount the date dial guard.	
10	Set the day star wheel and hook the day jumper of the date dial guard. Refer to the Fig. 55.	<p data-bbox="1675 256 2047 280"><11> Set the date dial. guard.</p>  <p data-bbox="1901 703 1971 727">Fig. 52</p>
9	Mount the intermediate wheel for day corrector. Refer to the Fig. 54.	 <p data-bbox="573 1382 642 1406">Fig. 51</p>
		<p data-bbox="1160 1018 1592 1098"><9>Mount the intermediate wheel for day corrector in the direction shown in the Fig. 54 below.</p>  <p data-bbox="1357 1334 1426 1358">Fig. 54</p>
		<p data-bbox="1664 943 2114 1023"><10> Set the day star wheel and hook the day jumper of the date dial guard as shown in the Fig. 55 below. ◆When mounting the day jumper, take care so as not to deform it.</p>  <p data-bbox="1693 1230 1890 1254">Day star wheel</p> <p data-bbox="1832 1382 1901 1406">Fig. 55</p>

No.	PROCESS	ILLUSTRATIONS AND SPECIAL INSTRUCTIONS ETC.
6	Mount the day lever spring without engaging.	<div style="display: flex; justify-content: space-around;"> <div data-bbox="680 204 1227 268" style="border: 1px solid black; padding: 5px;"><6>Mount the day lever spring.</div> <div data-bbox="1518 204 2159 300" style="border: 1px solid black; padding: 5px;"><2>Fix the day lever guard by tightening the day lever guard screws "a" and "b".</div> </div>
	↓	<div style="display: flex; justify-content: space-around;"> <div data-bbox="412 284 743 338" style="border: 1px solid black; padding: 5px;"><5>Mount the day lever.</div> <div data-bbox="1048 284 1460 338" style="border: 1px solid black; padding: 5px;"><3> Mount the day lever guard.</div> </div>
5	Mount the day lever.	
	↓	
4	Mount the day wheel.	
	↓	
3	Mount the day lever guard.	
	↓	
2	Fix the day lever guard by tightening the day lever guard screws.	
	↓	
	Securely hook the day lever spring underneath the tab of the day lever bridge. Refer to the Fig. 62.	<div style="display: flex; justify-content: space-around;"> <div data-bbox="443 357 1124 1050"> <p style="text-align: center;">Fig. 59</p> </div> <div data-bbox="1249 357 1930 1050"> <p style="text-align: center;">Fig. 60</p> </div> </div>
	↓	
	Lubricate the point of engagement between the day lever and day star wheel. Refer to the Fig. 61.	<div style="display: flex; justify-content: space-around;"> <div data-bbox="425 1129 797 1193" style="border: 1px solid black; padding: 5px;"><4>Mount the day wheel.</div> <div data-bbox="1066 963 1451 1458" style="border: 1px solid black; padding: 5px;"> <p>Lubricate the point of engagement between the day lever and day star wheel. ◆Type of oil:AO-3</p> <p style="text-align: center;">Fig. 61</p> </div> <div data-bbox="1733 976 2150 1458" style="border: 1px solid black; padding: 5px;"> <p>Securely hook the day lever spring underneath the tab of the day lever bridge.</p> <p style="text-align: center;">Fig. 62</p> </div> </div>

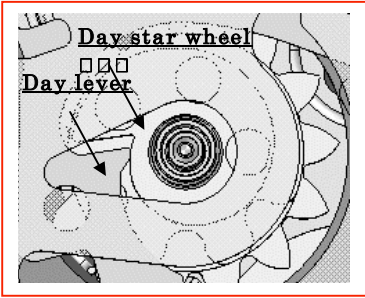
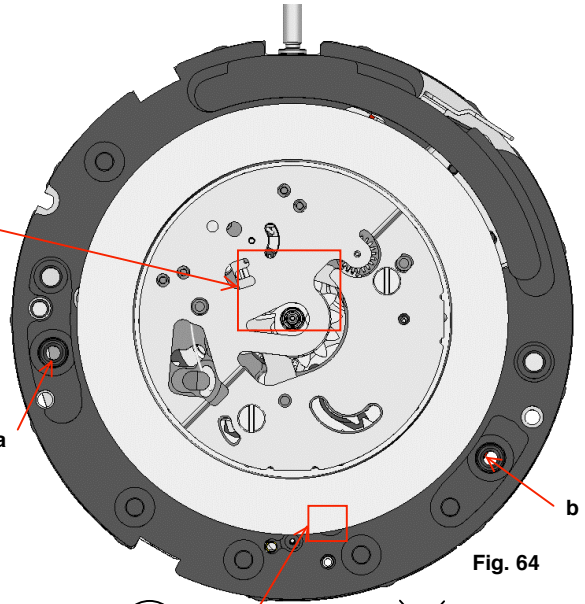
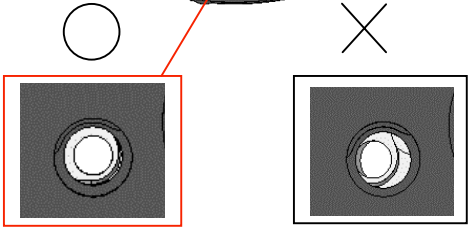
PROCESS	SPECIFICATIONS (QUALITY SPECIFICATIONS, HANDLING METHODS ETC.)
V) Function checks and installation of the exterior parts	
Check the movement of the winding stem and connected wheels.	<ul style="list-style-type: none"> ◆ Ensure that the winding stem works smoothly without being dragged at any position. <ul style="list-style-type: none"> • Pull out the winding stem to the first and second click position and vice versa. • Turn the crown clockwise and counterclockwise at each position.
Check the movement of the hands by winding the stem with crown at the second click position.	<ul style="list-style-type: none"> ◆ The hands should move smoothly without dropping off or being dragged while rotating or without any friction.
Check if the date and day are corrected when the crown is at the first click position.	<ul style="list-style-type: none"> ◆ Ensure that the calendar is corrected smoothly without any friction or resistance. ◆ Check full rotation of both the date dial and day star wheel.
Check if the date and day change correctly when the crown is at the second click position.	<ul style="list-style-type: none"> ◆ Ensure that the date and day correctly changes without any friction or resistance. ◆ The date and day should change instantly without being dragged. ◆ When the date changes, make sure that it does not advance for two days at one time. ◆ Make sure that the day changes correctly and instantly from the 7th day to the 1st.

No.	PROCESS	SPECIFICATIONS (QUALITY SPECIFICATIONS, HANDLING METHODS ETC.)	ILLUSTRATIONS AND SPECIAL INSTRUCTIONS ETC.
	Check the position of the day.	The day should be at the 1st day position. Make sure that the day lever and day star wheel are correctly mounted at the 1st day position. Refer to the Fig. 65.	<p>Make sure that the day lever and day star wheel are correctly mounted at the 1st day position as illustrated in the Fig. 65 below.</p>  <p>Fig. 65</p>
	Check the alignment of the power reserve wheels through the holes shown in the Fig. 66.		
	Mount the dial washer.	Take care so as not to bend or deform it.	
	Mount the end-piece for dial.	_____	
	Mount the dial.	Holes for dial fixing pins at “a” and “b”. Refer to the Fig. 64 at right.	 <p>Fig. 64</p>
	Check the clearance of the hour wheel.		 <p>Fig. 66</p>
	Preparation for mounting the direct drive indicator hand	(Refer to the instruction at right.)	<p>Preparation for mounting the direct drive indicator hand</p> <p>When the built-in IC is reset, the direct drive indicator hand temporarily returns to the 0 position and remains there for a period of maximum 9 minutes. <u>Carry out the following procedures within this time limit of 9 minutes.</u></p> <p><How to install the direct drive indicator hand after resetting the built-in IC></p> <ol style="list-style-type: none"> 1. With the winding stem at the second position, press the button located at the 10 o'clock position for 2 seconds or more. 2. After releasing the button, wait for 2 seconds or more, and then push the winding stem back to the original position. Doing this will trigger the system reset operation. The direct drive indicator hand returns to the 0 position (standby position). 3. Pull out the winding stem to the second position again and start mounting the hands. <p><i>Note) If the winding stem is at the original position or at the first click position, the direct drive indicator hand remains staying at the standby position for only 3 minutes after the built-in IC is reset.</i></p>

No.	PROCESS	SPECIFICATIONS (QUALITY SPECIFICATIONS, HANDLING METHODS ETC.)	ILLUSTRATIONS AND SPECIAL INSTRUCTIONS ETC.
	Mount the direct drive indicator hand.	The direct drive indicator hand should indicate the “0” position as illustrated at right. Push-in force: push it in with a force less than 2 kg.	 <p style="text-align: center;">Direct drive indicator hand</p>  <p style="text-align: center;">Day hand</p>
	Mount the day hand.	The day hand should indicate the “MON” position as illustrated at right. Push-in force: push it in with a force less than 2 kg.	
	Mount the hour hand.		
	Mount the minute hand.		
	Mount the second hand.		
	Check the hand installation height.	Make sure that the hands turn a full circle without having any friction with other hands or markings on the dial or the surface of the dial.	
	Check the movement of the hands.		
	↓		
	Check if the date and day change correctly.		
	↓		
	Remove the winding stem.	_____	
	Set the movement into the case.	Ensure that the case is firmly mounted without any clearance.	
	Set the winding stem with the crown.		
	Close the case back.		