

# 4006A (Seiko BELL-MATIC)

## 1. Specifications

Casing diameter	31.20 mm
Height	7.15 mm
Vibrations per hour	19,800
Automatic winding with sweep second Calendar (day and date)	
Instant date setting device	
Bell alarm device	

## 2. Structure of casing part

### 2-1. Glass

Glass with tension ring (Fig. 1 & 2)

### 2-2. Case back (Screw type)

A gasket mounted on the outside of the screwed part maintains a waterproof condition. (Fig. 1 & 2)

### 2-3. Securing the movement

The movement is secured by the casing spring which is located between the case back and the movement. (Fig. 2)

### 2-4. Crown

Ordinary waterproof type

### 2-5. Bell button

A bell button for setting the bell and date is attached at the 2 o'clock position.

This bell button is of the same waterproof construction as the crown of the recessed crown type. (Fig. 3)

### 2-6. Dial

Dial is especially shaped, provided with an edge to determine the positions of the dial and the alarm setting wheel. (Fig. 1)

### 2-7. Alarm setting wheel

An alarm setting wheel is provided on the dial periphery. This feature is found only in the 4006A which excels both in

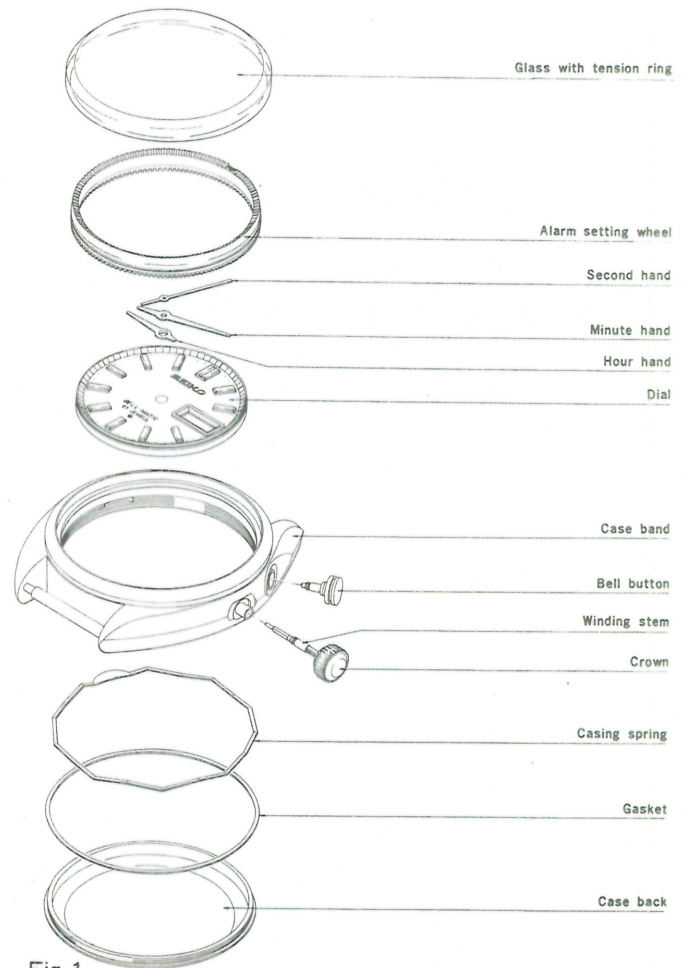

Fig. 1

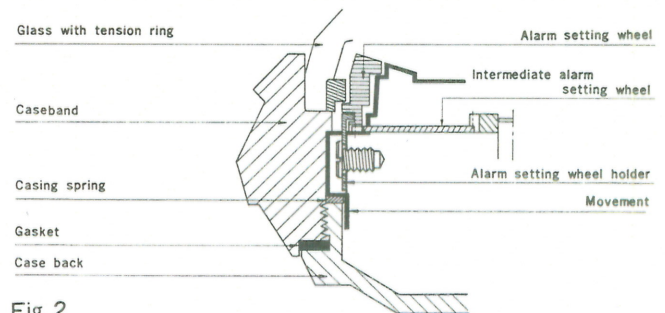

Fig. 2

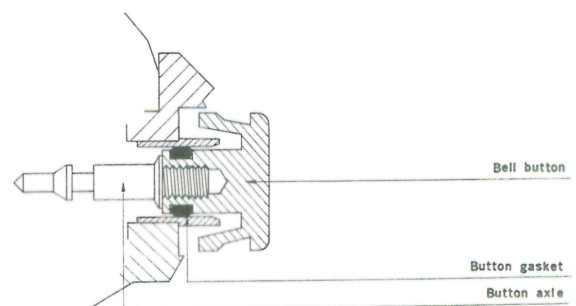

Fig. 3

design and function. The alarm setting wheel is secured to the movement through an alarm setting wheel holder, and it interlocks with the alarm setting train and crown. (Fig. 2)

### 3. Automatic winding mechanism

#### 3-1. Exploded view of automatic winding mechanism (Fig. 4)

#### 3-2. Transmission of force in automatic winding mechanism (Fig. 5)

- An eccentric pin in a ball bearing performs circular motions by right and left rotations of the oscillating weight.
- The pawl lever performs reciprocative motions due to circular movement of the eccentric pin, and the pawl lever rotates the transmission wheel constantly in one direction.
- This motion is transmitted to the ratchet wheel from the transmission wheel; thus, the mainspring is wound.
- Since a pawl lever is adopted, whose actions transmit right and left rotations of the oscillating weight in one direction—magnifying the rotating force—and prevent reversal motion of the main-spring, this automatic winding mechanism is extremely simplified.
- In addition to the simplified construction, all automatic winding parts are set on the framework for automatic device; as a result, disassembling and reassembling are extremely easy.

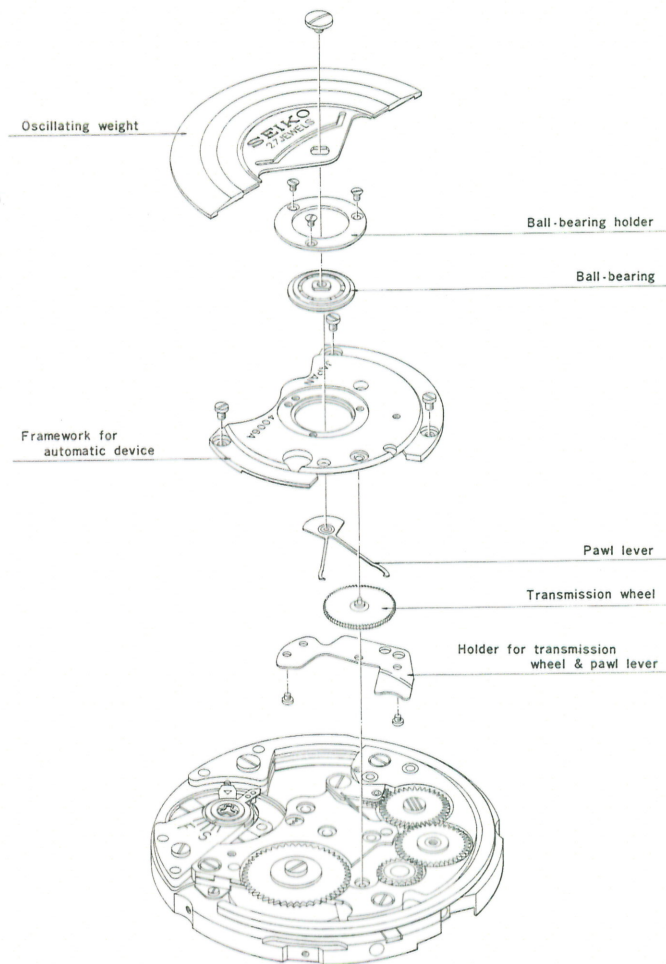

Fig. 4

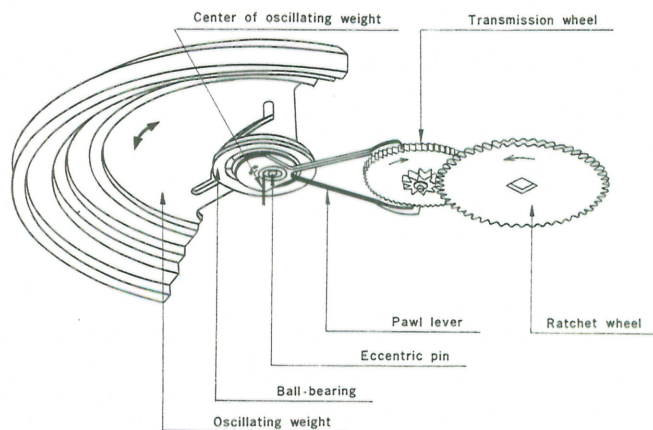
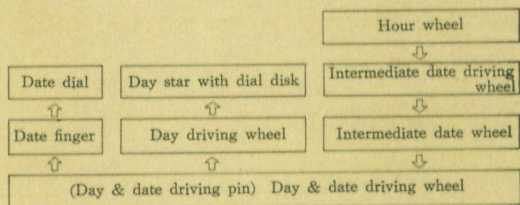

Fig. 5

4 Calendar and bell alarm mechanism

4-1. Exploded view of calendar and bell alarm mechanism (Fig. 6)

4-2. Mechanism of calendar device (Fig. 7)



4-3. Date setting (Fig. 8)

By depressing the bell button, the date corrector is actuated and the date dial driven.

Due to one-side free mechanism of the date finger, date correction through the button can be achieved even in a condition when the date finger is forwarding the date dial.

4-4. Day setting

Day setting can be performed by alternating the hands between 9:30 P.M. to 1:00 A.M. on the dial.

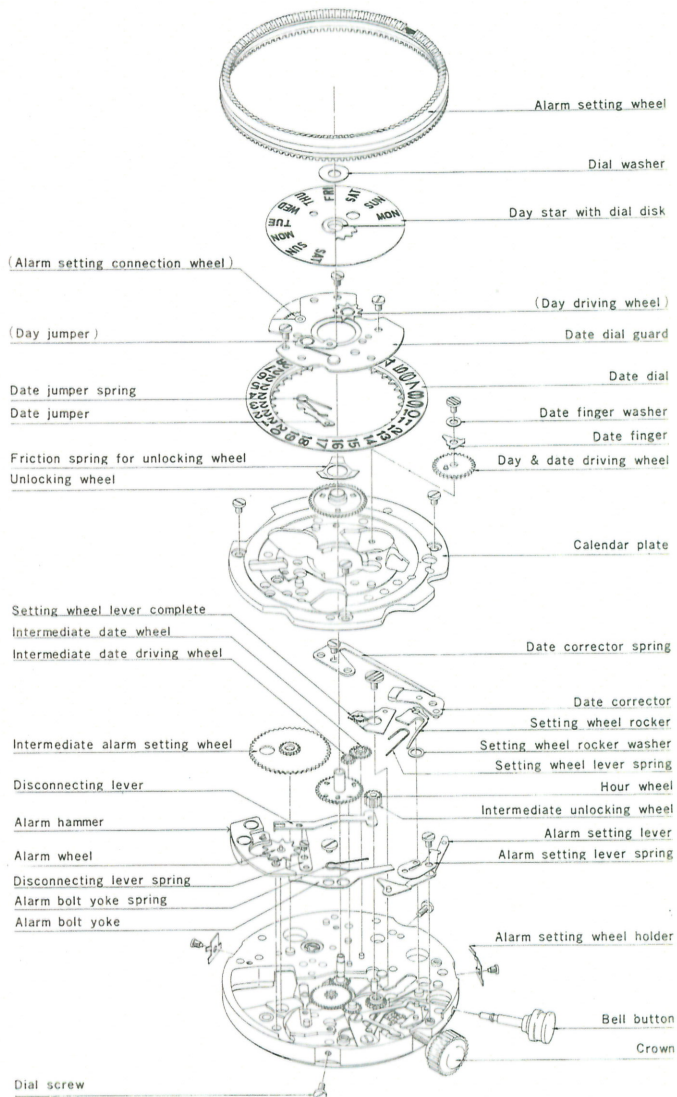

Fig. 6

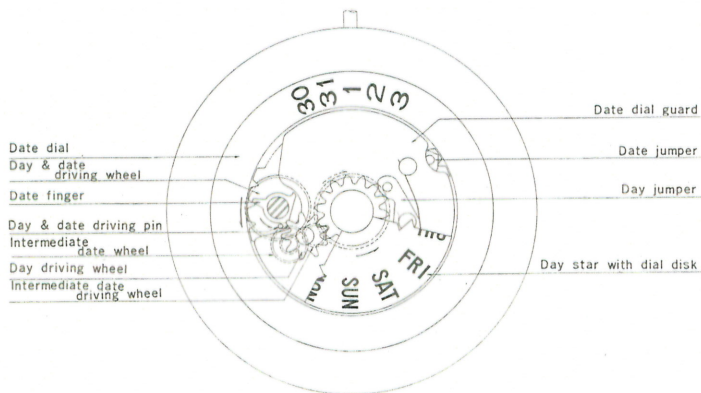

Fig. 7

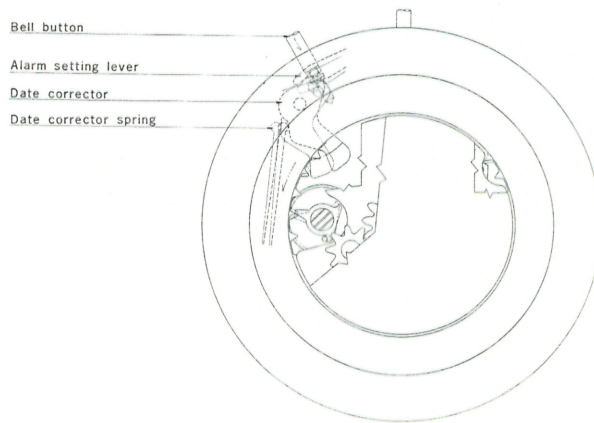

Fig. 8

**4-5. Setting mechanism**

The setting mechanism consists of the crown (three-position changeover) and bell button (two-position changeover and push).

**Turning the hands (Fig. 9)**

When the crown is pulled out to the third position, the yoke is pushed by the setting lever, meshing the clutch wheel and setting wheel.

At the same time, the setting wheel lever complete is pushed by the pin on the setting lever through the setting wheel rocker so that the intermediate setting wheel and the intermediate minute wheel are engaged. Therefore, by turning the crown hereon, force is transmitted in the sequence of clutch wheel→setting wheel→intermediate setting wheel→intermediate minute wheel→minute wheel→hour wheel·cannon pinion... thus turning the hands.

**Winding the alarm mainspring**

(Fig. 10, 11 & 12)

When the crown is under the first position, the clutch and the winding pinion are engaged with each other. By turning the crown, force is transmitted in the sequence of clutch wheel→winding pinion→crown wheel→intermediate winding wheel→alarm ratchet wheel...winding the alarm mainspring. (Fig. 10 & 11) If the bell button is pulled out, however, the yoke is pushed by the alarm setting lever; accordingly, under this condition the clutch wheel and winding pinion are disengaged, and the alarm mainspring is not wound. (Fig. 12) The intermediate wheel rocker for alarm serves as a click. When the spring is about to return (by force applied in the opposite direction indicated by the arrow mark), the alarm ratchet wheel and the alarm intermediate wheel are engaged with each other. This torque is transmitted in the sequence of the alarm intermediate wheel→alarm wheel→alarm hammer. Since the alarm hammer is stopped by the alarm bolt yoke, the spring remains wound. When winding the alarm mainspring, the intermediate wheel rocker spring for alarm will bend; consequently, the intermediate wheel and the alarm wheel are disengaged.

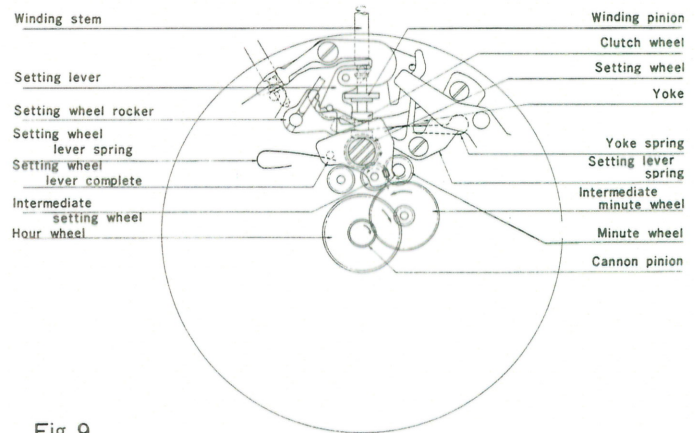

Fig. 9

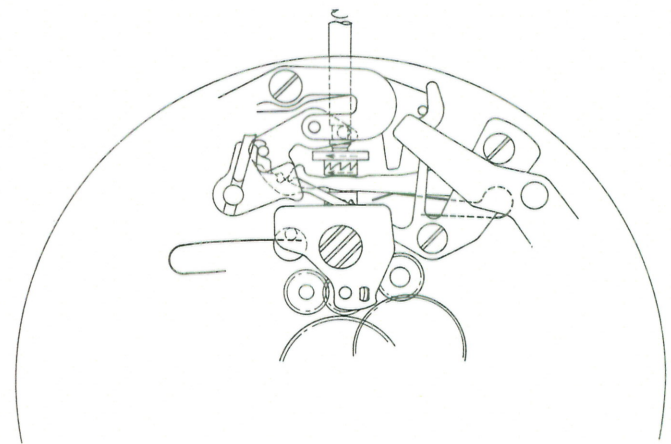

Fig. 10

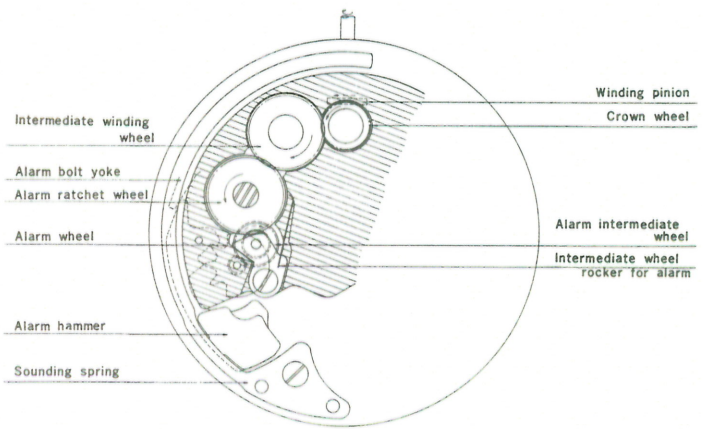

Fig. 11

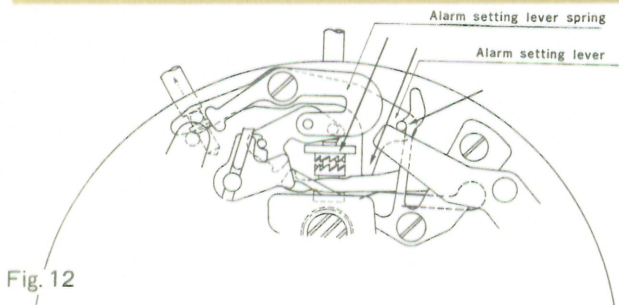

Fig. 12

**Bell time setting (Fig. 13)**

When the crown is pulled out to the second position, the yoke is pushed by the setting lever so that the clutch wheel and the setting wheel are meshed with each other. Under this condition, the setting wheel lever complete is held in a position shown in Fig. 13 by means of the setting lever spring, and the intermediate setting wheel is engaged with the intermediate unlocking wheel. Therefore, by turning the crown, torque is transmitted in the sequence of the clutch wheel→setting wheel→intermediate setting wheel→intermediate unlocking wheel...turning the unlocking wheel. Subsequently, torque is further transmitted in the sequence of the unlocking wheel→alarm setting connection wheel→intermediate alarm setting wheel...turning the alarm setting wheel. Under this condition, bell timing can be accurately set. The alarm setting wheel, interlocking with the unlocking wheel, serves to indicate the bell ringing position on the dial. The spring attached to the setting wheel rocker functions to press the alarm setting wheel as shown in Fig. 14 when the crown is depressed on completion of setting the bell time, preventing the alarm setting wheel from moving through receiving mechanical shocks.

**Bell setting (Fig. 15)**

When the bell button is pulled to the second position, the alarm setting lever is actuated, separating the alarm bolt yoke from the hammer; thus the bell is prepared for ringing. When the preset bell time arrives, the hammer is actuated and the bell rings. At this time, the alarm setting lever pushes the yoke, disengaging the winding pinion and the clutch wheel from each other. Therefore, the winding train wheel is reversed as far as the winding pinion. Until the bell ringing time arrives, the hammer is stopped by the disconnecting lever.

**Ringling the bell (Fig. 16)**

When the time indicated by the set mark is reached, the projection of the hour wheel is aligned with the unlocking wheel hole. Under this condition, the hour wheel and disconnecting lever are both raised by the disconnecting lever spring, resulting in separation of the disconnecting lever from the hammer. Then the hammer beats the sounding spring continuously, sounding the bell until the force of the alarm mainspring is expended.

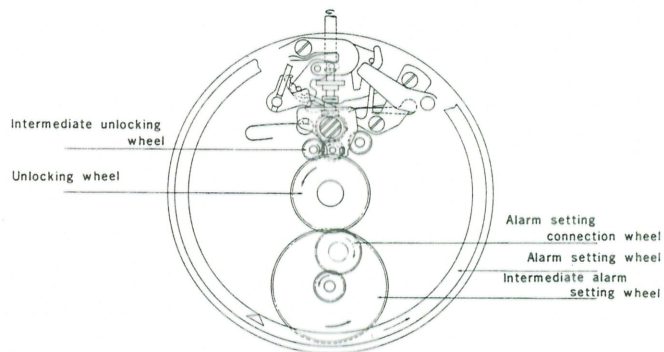

Fig. 13

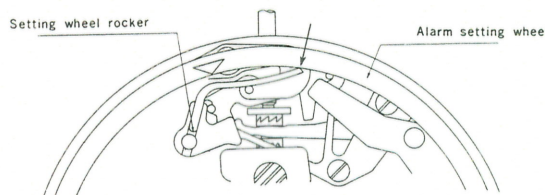

Fig. 14

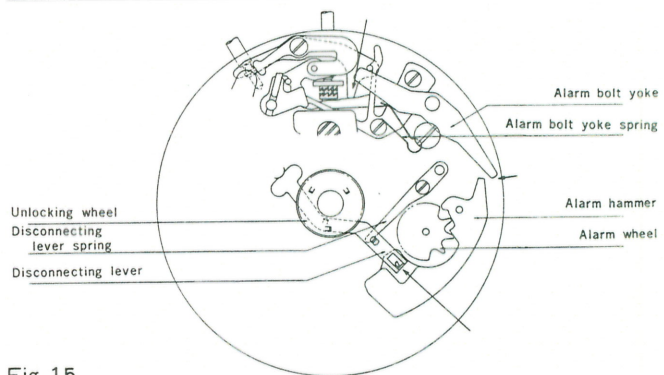

Fig. 15

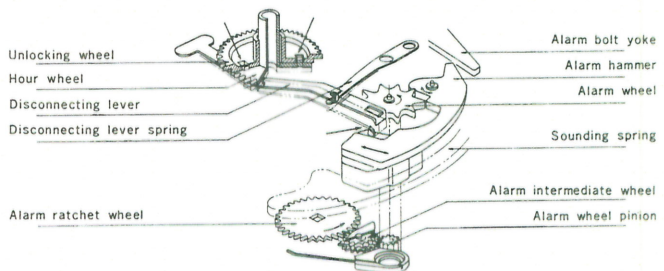

Fig. 16

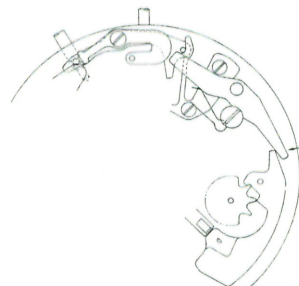

Fig. 17

**Stopping the bell (Fig. 17)**

When the bell button is pushed to the first position, the hammer is held by the alarm bolt yoke, stopping the bell from ringing.

**5. Movement**

*Exploded view of movement*

(Fig. 18 & 19)

**6. Disassembly, assembly, and checking**

Refer to the following pages.

4006A-7~4006A-17.

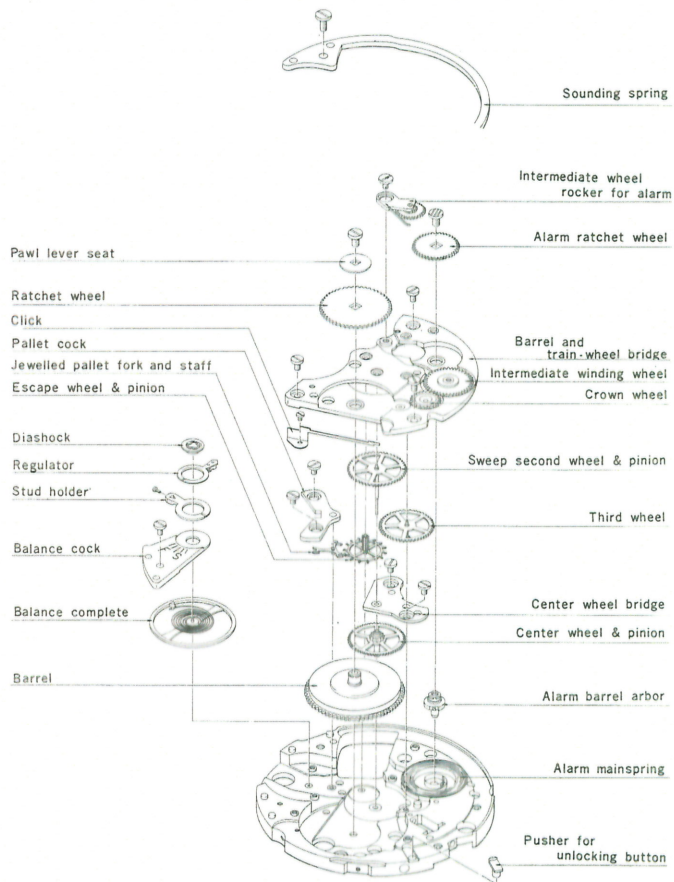

Fig. 18

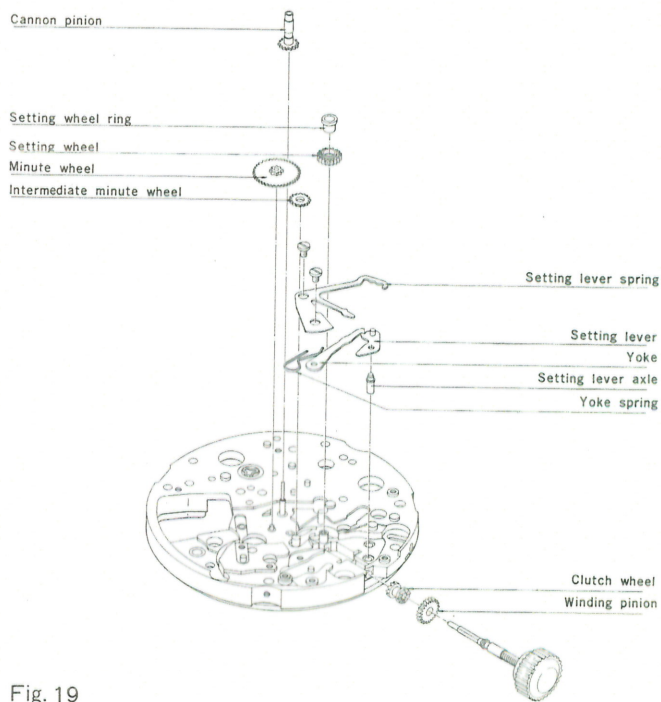

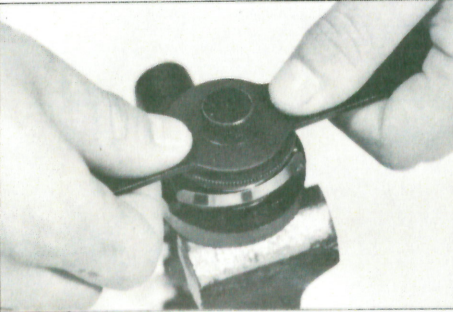
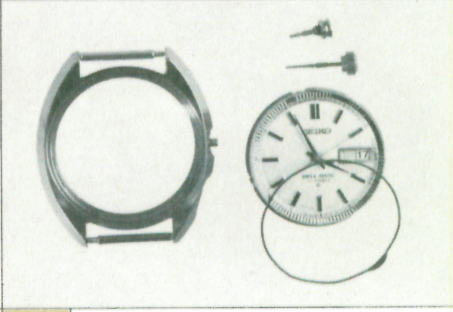
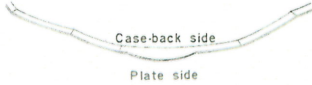
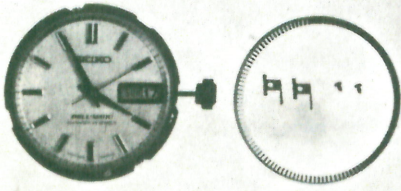
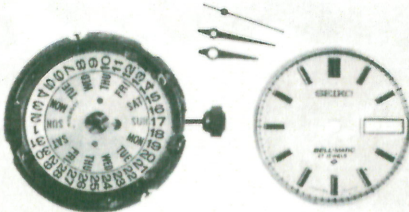



Fig. 19



## 4006A Disassembly and assembly—continued

Disassembly	Method	Remark	Photo
	<p><b>1 CASE BACK</b></p> <ol style="list-style-type: none"> <li>1) Set case in case-holder held by vise</li> <li>2) Remove case back with SEIKO case opener</li> <li>3) Remove case back gasket</li> </ol> <p>Concerning use of case-holder and opener, refer to item entitled Instruments for Repairing and Testing Machines.</p>		
	<p><b>2 REMOVAL OF MOVEMENT</b></p> <ol style="list-style-type: none"> <li>1) Remove case spring</li> <li>2) Remove bell button by pushing pusher for unlocking button</li> <li>3) Remove winding stem by pushing setting lever axle</li> <li>4) Turn case upside down and gently remove movement from case. Be careful not to deform case spring</li> </ol>	<p>Usually there is no need of removing glass; however, when it is necessary to do so, remove glass by pushing it from inside. (It is not necessary to remove bezel.)</p>	
			
			
Assembly	Method	Remark	
	<p><b>32 CHECKING</b></p> <ol style="list-style-type: none"> <li>1) Space between hands</li> <li>2) The position of crown</li> <li>3) Rotation of hands</li> <li>4) Positions of hour and minute hands at 12 o'clock</li> <li>5) Date changes near midnight; day changes near 1 A.M.</li> <li>6) Date setting</li> <li>7) Bell time setting</li> <li>8) Stopping the bell</li> <li>9) Waterproof test</li> </ol>		
	<p><b>31 CASE BACK</b></p> <ol style="list-style-type: none"> <li>1) Thinly apply silicon grease (500,000 c.s.) to case back gasket</li> <li>2) Mount case back gasket on case back</li> <li>3) Assemble case back with case-holder and opener. Tighten case back securely and completely.</li> </ol>		
	<p><b>30 CASING</b></p> <ol style="list-style-type: none"> <li>1) Remove winding stem and bell button</li> <li>2) Insert movement in case</li> <li>3) Apply silicon grease (500,000 c.s.) to crown gasket</li> <li>4) Set winding stem</li> <li>5) Apply silicon grease (500,000 c.s.) to bell button gasket</li> <li>6) Set bell button</li> <li>7) Align projection of casing spring with dented portion on the case (near balance wheel) and set casing spring (Refer to drawing to avoid confusing front and back)</li> </ol>		

## 4006A Disassembly and assembly—continued

	<b>3</b>	<b>4</b>	<b>5</b>
<b>Disassembly</b>	<b>ALARM SETTING WHEEL</b>	<b>DIAL</b>	<b>DAY STAR WITH DIAL DISK</b>
<b>Method</b>	<ol style="list-style-type: none"> <li>1) Set winding stem to facilitate disassembling (It can be set by merely inserting winding stem without pushing setting lever axle)</li> <li>2) Remove alarm setting wheel holder screws (2 pcs.)</li> <li>3) Remove alarm setting wheel holders</li> <li>4) After pulling crown to second or third position, remove alarm setting wheel</li> </ol>	<ol style="list-style-type: none"> <li>1) Remove second hand, minute hand, and hour hand</li> <li>2) Loosen dial screws and remove dial</li> </ol>	<ol style="list-style-type: none"> <li>1) Remove dial washer and day star with dial disk</li> </ol>
<b>Remark</b>	Setting wheel rocker spring is designed to project from periphery of plate; consequently, disassemble or reassemble watch very carefully. When crown is pulled to second or third position, spring withdraws.		
<b>Photo</b>			
<b>Assembly</b>	<b>29</b>	<b>28</b>	<b>27</b>
<b>Method</b>	<ol style="list-style-type: none"> <li>1) Pull crown to third position and turn it, then set hands to 12 o'clock</li> <li>2) Turn crown at second position, stopping crown at moment bell begins to ring. Then set alarm setting wheel in such a position that its set-mark is aligned with 12 o'clock</li> <li>3) Set alarm setting wheel holders and screws while holding alarm setting wheel and intermediate alarm setting wheel in an engaged condition</li> <li>4) Check bell ringing time and reset alarm setting wheel if too large an error of bell ringing time exists (Normal tolerance : ± 5 minutes)</li> </ol>	<ol style="list-style-type: none"> <li>1) Set dial and tighten dial screws</li> <li>2) Turn crown at third position, stop crown on moment when date dial is changed, and set hour hand and minute hand to 12 o'clock</li> <li>3) When projection of hour wheel enters hole of unlocking wheel (bell ringing time), check clearance between hour hand and dial (As hands advance, one position is reached where hour hand is elevated to a higher position. Reverse hands therefrom and check hour hand and minute hand by setting one over the other)</li> <li>4) Set second hand</li> </ol>	<ol style="list-style-type: none"> <li>1) Correct day jumper position</li> <li>2) Set day star with dial disk (Mesh day star with day jumper head through hole of dial disk)</li> <li>3) Set dial washer</li> </ol>
<b>Remark</b>			Proper height of dial washer is 0.25mm, equal to thickness of setting lever spring.

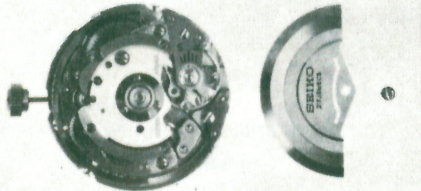
## 4006A Disassembly and assembly—continued

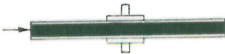
<b>Disassembly</b>	<b>6</b>	<b>OSCILLATING WEIGHT</b> 1) Remove screw for oscillating weight 2) Remove oscillating weight	<b>7</b>	
<b>Method</b>			<b>FRAMEWORK FOR AUTOMATIC DEVICE</b> 1) Remove framework screws for automatic device (3 pcs.) 2) Remove framework for automatic device	
<b>Remark</b>				
<b>Photo</b>				
<b>Assembly</b>	<b>26</b>	<b>25</b>	<b>24</b>	
<b>Method</b>	<b>INSPECTION</b> 1) Make sure that pawl lever is correctly engaged with transmission wheel 2) Check automatic winding operating conditions 3) Inspect overall movement	<b>OSCILLATING WEIGHT</b> 1) Set oscillating weight and screw for oscillating weight	<b>FRAMEWORK FOR AUTOMATIC DEVICE</b> 1) Lubricate upper and lower hole jewels of transmission (watch oil S-4 or Moebius grease "Remontoires") 2) Ascertain that transmission wheel is engaged with ratchet wheel and tighten framework screws for automatic device (Confirm by turning ratchet wheel) 3) Lubricate transmission wheel tooth surface (watch oil S-4 or Moebius grease "Remontoires")	
<b>Remark</b>		Tighten screw for oscillating weight securely. Check contacting conditions with sounding spring.		

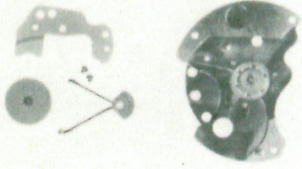
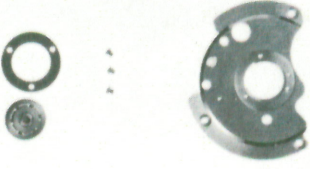
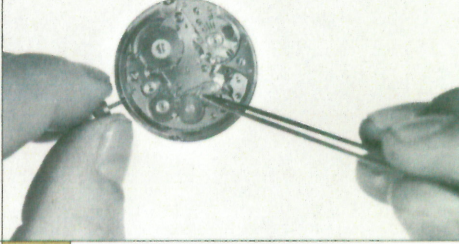
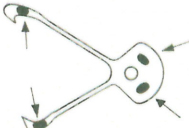
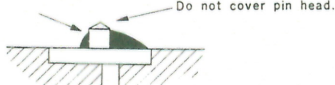

## 4006A Disassembly and assembly—continued

Disassembly	<b>8</b>	<b>TRANSMISSION WHEEL</b>	<b>9</b>	<b>BALL-BEARING</b>	<b>10</b>	<b>ALARM MAINSPRING</b>
	<ol style="list-style-type: none"> <li>1) Remove holder screws for transmission wheel and pawl lever (2 pcs.)</li> <li>2) Remove holder for transmission wheel and pawl lever</li> <li>3) Remove transmission wheel and pawl lever</li> </ol>		<ol style="list-style-type: none"> <li>1) Remove ball-bearing holder screws (3 pcs.)</li> <li>2) Remove ball-bearing holder.</li> <li>3) Remove ball-bearing.</li> </ol>		<ol style="list-style-type: none"> <li>1) Disengage alarm intermediate wheel and alarm wheel pinion with a pair of tweezers (by turning intermediate wheel rocker for alarm clockwise); then unwind alarm mainspring slowly by operating crown (see photo) or by ringing bell</li> </ol>	
	Be careful not to deform pawl lever.		Ball-bearing cannot be disassembled.			
Photo						
Assembly	<b>23</b>	<b>TRANSMISSION WHEEL</b>	<b>22</b>	<b>BALL-BEARING</b>	<b>21</b>	<b>CHECK ON BELL RINGING CONDITION</b>
	<ol style="list-style-type: none"> <li>1) Lubricate pawl lever (watch oil S-4 or Moebius grease "Remontoires")</li> <li>2) Set transmission wheel</li> <li>3) Set pawl lever and mesh it with transmission wheel</li> <li>4) Set holder for transmission wheel and pawl lever, and holder screws for transmission wheel and pawl lever</li> </ol>		<ol style="list-style-type: none"> <li>1) Set ball-bearing, ball-bearing holder, and ball-bearing holder screws</li> <li>2) Lubricate each ball in ball-bearing with Moebius Synt-A-Lube</li> <li>3) Lubricate eccentric pin (watch oil S-4); See remarks below</li> </ol>		<ol style="list-style-type: none"> <li>1) Wind alarm mainspring and pull out bell button. Turn crown at second position, making sure that bell rings when projections of hour wheel fit in holes of unlocking wheel</li> <li>2) Check date correction and date driving conditions</li> </ol>	
						
Remark						

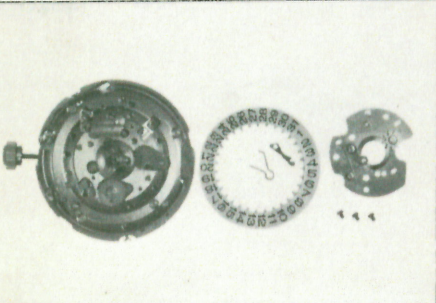
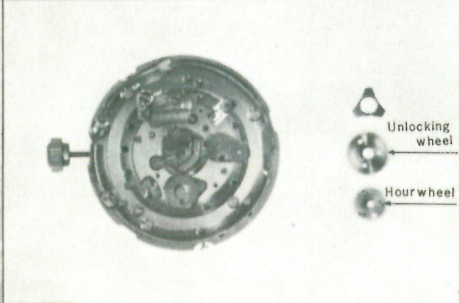
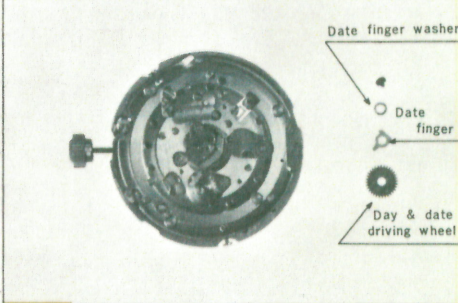
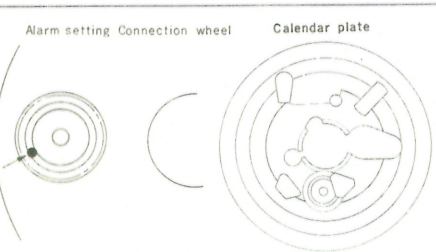
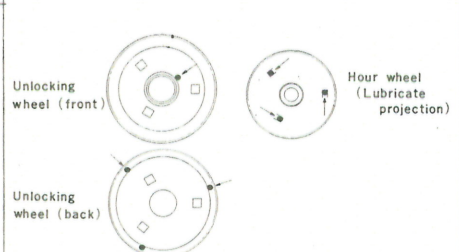

## 4006A Disassembly and assembly—continued

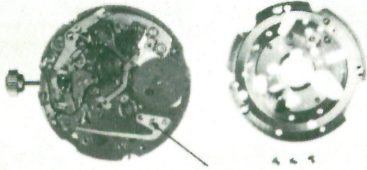
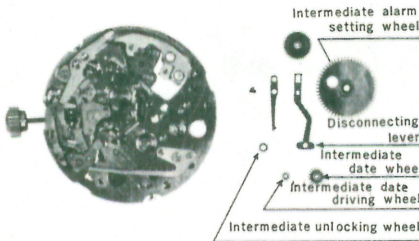
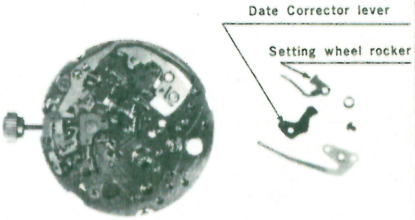
	<b>11</b> <b>DATE DIAL</b>	<b>12</b> <b>HOUR WHEEL</b>	<b>13</b> <b>DAY &amp; DATE DRIVING WHEEL</b>
<b>Disassembly</b>	<p><b>Method</b></p> <ol style="list-style-type: none"> <li>1) Remove date dial guard screws (3 pcs.)</li> <li>2) Remove date dial guard</li> <li>3) Remove date jumper spring and date jumper</li> <li>4) Remove date dial</li> </ol>	<ol style="list-style-type: none"> <li>1) Remove friction spring for unlocking wheel</li> <li>2) Remove unlocking wheel</li> <li>3) Remove hour wheel</li> </ol>	<ol style="list-style-type: none"> <li>1) Remove screw for day and date driving wheel</li> <li>2) Remove date finger washer, date finger, and day &amp; date driving wheel</li> </ol>
<b>Remark</b>			Because it has left-handed threads, loosen screw for day & date driving wheel by turning it to the right.
<b>Photo</b>			
<b>Assembly</b>	<p><b>Method</b></p> <ol style="list-style-type: none"> <li>1) Lubricate date dial contacting part of calendar plate (Moebius Synt-A-Lube)</li> <li>2) Lubricate alarm setting connection wheel on back side of date dial guard (Moebius Synt-A-Lube)</li> <li>3) Set date dial</li> <li>4) Lubricate engaging part between date jumper and date dial (Moebius Synt-A-Lube)</li> <li>5) Set date jumper and date jumper spring</li> <li>6) Set date dial guard and screws</li> </ol>	<p><b>Method</b></p> <ol style="list-style-type: none"> <li>1) Lubricate upper and lower pivot of alarm wheel and alarm hammer (watch oil S-4 or Moebius grease "Remontoires")</li> <li>2) Lubricate cannon pinion (Moebius Synt-A-Lube)</li> <li>3) Lubricate hour wheel (Moebius Synt-A-Lube)</li> <li>4) Set hour wheel</li> <li>5) Lubricate unlocking wheel with watch oil S-4 or Moebius grease "Remontoires"</li> <li>6) Set unlocking wheel</li> </ol>	<p><b>Method</b></p> <ol style="list-style-type: none"> <li>1) Lubricate day &amp; date driving wheel axle (Moebius Synt-A-Lube)</li> <li>2) Set day &amp; date driving wheel</li> <li>3) Set date finger</li> <li>4) Set date finger washer (open downward)</li> <li>5) Set the screw for day and date driving wheel (tighten by turning to left)</li> </ol>
<b>Remark</b>			<p>Be sure to position date finger against day driving pin correctly (refer to photo of Hour Wheel)</p>

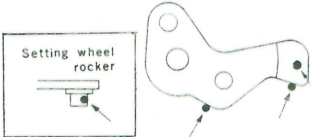

## 4006A Disassembly and assembly—continued

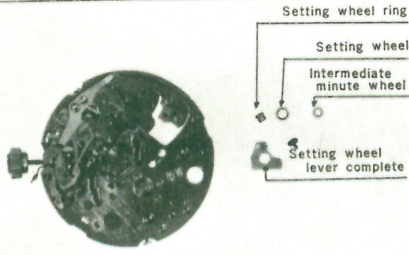
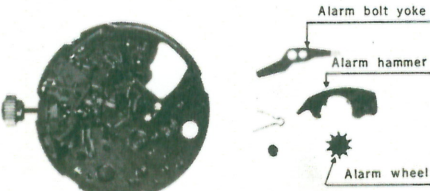
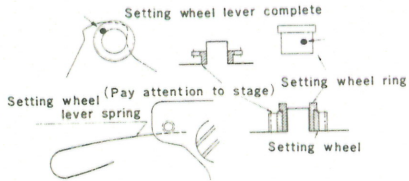
	<b>14</b>	<b>15</b>	<b>16</b>
<b>Disassembly</b>	<b>CALENDAR PLATE</b>	<b>INTERMEDIATE ALARM SETTING WHEEL</b>	<b>DATE CORRECTOR LEVER</b>
<b>Method</b>	<ol style="list-style-type: none"> <li>1) Remove calendar plate screws (3 pcs.)</li> <li>2) Remove calendar plate</li> </ol>	<ol style="list-style-type: none"> <li>1) Remove intermediate alarm setting wheel</li> <li>2) Remove intermediate date wheel</li> <li>3) Remove intermediate date driving wheel</li> <li>4) Remove disconnecting lever</li> <li>5) Remove disconnecting lever spring screw</li> <li>6) Remove disconnecting lever spring</li> <li>7) Remove minute wheel</li> <li>8) Remove intermediate unlocking wheel</li> </ol>	<ol style="list-style-type: none"> <li>1) Remove date corrector lever spring screw</li> <li>2) Remove date corrector lever spring</li> <li>3) Remove date corrector lever</li> <li>4) Remove setting wheel rocker</li> <li>5) Remove setting wheel rocker washer</li> </ol>
<b>Remark</b>	Do not inadvertently remove the screw indicated by arrow in photo. It is date corrector spring screw. Intermediate date driving wheel and intermediate unlocking wheel are often removed together with calendar plate.		
<b>Photo</b>			
<b>Assembly</b>	<b>17</b>	<b>16</b>	<b>15</b>
<b>Method</b>	<ol style="list-style-type: none"> <li>1) Set calendar plate and its screws</li> <li>2) Check bell for ringing conditions. Wind alarm mainspring with crown, ascertaining that bell rings when bell button is pulled out to second position. If bell does not ring, check disconnecting lever or alarm train.</li> </ol>	<ol style="list-style-type: none"> <li>1) Lubricate intermediate unlocking wheel axle and minute wheel axle (Moebius Synt-A-Lube)</li> <li>2) Set intermediate unlocking wheel</li> <li>3) Set minute wheel</li> <li>4) Lubricate intermediate date driving wheel axle, intermediate date wheel axle, and alarm setting connection wheel axle (Moebius Synt-A-Lube)</li> <li>5) Set intermediate date driving wheel, intermediate date wheel, and intermediate alarm setting wheel</li> <li>6) Set disconnecting lever spring and its screw</li> <li>7) Lubricate disconnecting lever (watch oil S-4)</li> <li>8) Set disconnecting lever</li> </ol>	<ol style="list-style-type: none"> <li>1) Lubricate setting wheel rocker axle (watch oil S-4)</li> <li>2) Set setting wheel rocker washer and setting wheel rocker (set crown to first position)</li> <li>3) Lubricate date corrector lever axle (watch oil S-4, Moebius grease "Remontoires" or Moebius Synt-A-Lube)</li> <li>4) Set date corrector lever after lubricating it (watch oil S-4 and Moebius Synt-A-Lube)</li> </ol>
<b>Remark</b>			

## 4006A Disassembly and assembly—continued

<b>Disassembly</b>	<b>17</b>	<b>SETTING WHEEL LEVER COMPLETE</b>	<b>18</b>	<b>ALARM HAMMER</b>	<b>19</b>	<b>UNWINDING MAINSPRING</b>
	<ol style="list-style-type: none"> <li>1) Remove setting wheel lever screw</li> <li>2) Remove setting wheel lever complete</li> <li>3) Remove setting wheel lever spring</li> <li>4) Remove setting wheel ring and setting wheel</li> <li>5) Remove intermediate minute wheel</li> </ol>		<ol style="list-style-type: none"> <li>1) Remove alarm wheel</li> <li>2) Remove alarm hammer</li> <li>3) Remove alarm bolt yoke spring</li> <li>4) Remove alarm bolt yoke screw</li> <li>5) Remove alarm bolt yoke</li> </ol>			
	<p>Because it has left-handed threads, loosen setting wheel lever screw by turning it to right.</p>				<p>When unwinding mainspring, let it unwind solely by its returning force.</p>	
<b>Assembly</b>	<b>14</b>		<b>13</b>	<b>ALARM HAMMER</b>	<b>12</b>	<b>AMPLITUDE INSPECTION</b>
	<ol style="list-style-type: none"> <li>1) Lubricate setting wheel ring and intermediate minute wheel axle (Moebius Synt-A-Lube)</li> <li>2) Set setting wheel and setting wheel ring</li> <li>3) Set intermediate minute wheel</li> <li>4) Lubricate setting wheel lever complete (Moebius Synt-A-Lube)</li> <li>5) Set setting wheel lever complete</li> <li>6) Set setting wheel lever screw (tighten by turning to left)</li> <li>7) Ascertain that setting wheel lever complete moves to right and left smoothly</li> <li>8) Set setting wheel lever spring</li> </ol>		<ol style="list-style-type: none"> <li>1) Lubricate alarm bolt yoke axle (watch oil S-4)</li> <li>2) Lubricate alarm bolt yoke (watch oil S-4)</li> <li>3) Set alarm bolt yoke</li> <li>4) Set alarm bolt yoke screw (confirm mounting position by referring to 14)</li> <li>5) Set alarm bolt yoke spring</li> <li>6) Set alarm wheel</li> <li>7) Lubricate alarm hammer (watch oil S-4 or Moebius grease "Remontoires")</li> <li>8) Set alarm hammer</li> </ol>		<ol style="list-style-type: none"> <li>1) Check condition of hairspring</li> <li>2) Wind spring fully Hold movement vertical and check amplitude making sure that amplitude is 180° or larger (spring can be fully wound by turning ratchet wheel 8 or more times)</li> </ol>	
<b>Photo</b>						
<b>Remark</b>						

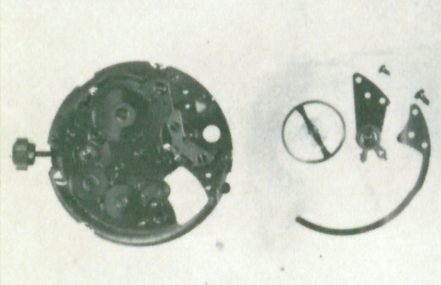

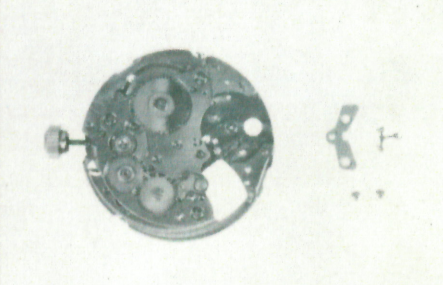
## 4006A Disassembly and assembly—continued

	<b>20</b>	<b>21</b>	<b>22</b>
<b>Disassembly</b>	<b>BALANCE COMPLETE</b>	<b>DIASHOCK</b>	<b>PALLET</b>
<b>Method</b>	<ol style="list-style-type: none"> <li>1) Remove sounding spring screw</li> <li>2) Remove sounding spring</li> <li>3) Remove balance cock screw</li> <li>4) Remove balance cock</li> <li>5) Loosen stud screw and remove stud from stud holder</li> <li>6) Remove balance by turning regulat key</li> </ol>	<ol style="list-style-type: none"> <li>1) Remove Diashock springs from plate and balance cock</li> <li>2) Remove cap jewel and hole jewel with frame, cleaning them with benzine or trichlorethylene</li> </ol>	<ol style="list-style-type: none"> <li>1) Remove pallet cock screws (2 pcs.)</li> <li>2) Remove pallet cock</li> <li>3) Remove pallet</li> </ol>
<b>Remark</b>	Pay attention to any deformation of sounding spring.	Wash with fresh cleaning solution using a brush.	
<b>Photo</b>			
<b>Assembly</b>	<b>11</b>	<b>10</b>	<b>9</b>
<b>Method</b>	<ol style="list-style-type: none"> <li>1) Set balance on balance cock</li> <li>2) Place hairspring on regulator key and turn key</li> <li>3) Tighten stud to stud holder with a screw. Flush upper surfaces of stud head and stud holder</li> <li>4) Set balance cock and its screw</li> <li>5) Set sounding spring and its screw</li> </ol>	<ol style="list-style-type: none"> <li>1) Place cap jewel with flat surface upward</li> <li>2) Put drop of oil on its center, holding cap jewel with tweezers. Extent of lubrication : Dia. of hole jewels. Max. 1/2 Min. 1/3</li> <li>3) Set Diashock frame with hole jewel directly over oiled cap jewel</li> </ol>	<ol style="list-style-type: none"> <li>1) Lubricate pallet jewels with Moebius Synt-A-Lube</li> <li>2) Set pallet</li> <li>3) Set pallet cock and screws</li> <li>4) Check end shake of pallet</li> </ol>
<b>Remark</b>	Check sounding spring and plate for contacting condition. (If sounding spring contacts something, a proper sound will not result.)	Lubricating Diashock: For assembling it in plate, refer to item on Diashock.	

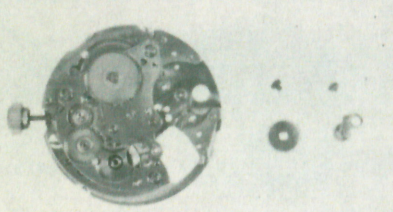
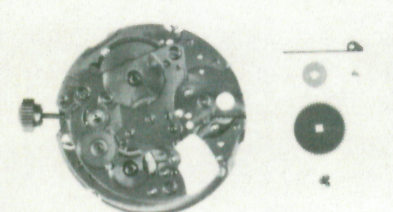
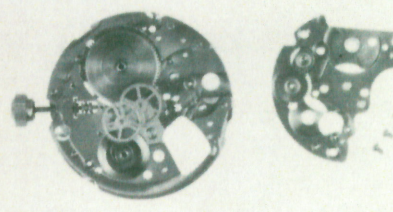
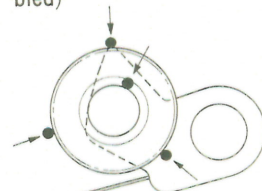
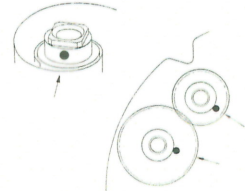
## 4006A Disassembly and assembly—continued

<b>Disassembly</b>	<b>23</b>	<b>24</b>	<b>25</b>
	<b>ALARM RATCHET WHEEL</b>	<b>RATCHET WHEEL</b>	<b>BARREL AND TRAIN-WHEEL BRIDGE</b>
<b>Method</b>	<ol style="list-style-type: none"> <li>1) Remove alarm ratchet wheel screw</li> <li>2) Remove alarm ratchet wheel</li> <li>3) Remove intermediate wheel rocker screw for alarm</li> <li>4) Remove intermediate wheel rocker for alarm</li> </ol>	<ol style="list-style-type: none"> <li>1) Remove ratchet screw</li> <li>2) Remove pawl lever seat and ratchet wheel</li> <li>3) Remove click screw</li> <li>4) Remove click</li> </ol>	<ol style="list-style-type: none"> <li>1) Remove bridge screws (3 pcs.)</li> <li>2) Remove barrel and train wheel bridge</li> </ol>
<b>Remark</b>	Because it has left-handed threads, loosen alarm ratchet wheel screw by turning it to the right. Pay attention to any deformation of spring of intermediate wheel rocker for alarm.		Do not disassemble crown wheel and intermediate winding wheel from the bridge. Remove barrel and train wheel bridge while holding alarm barrel arbor so that alarm mainspring does not project.
<b>Photo</b>			
<b>Assembly</b>	<b>8</b>	<b>7</b>	<b>6</b>
	<b>ALARM RATCHET WHEEL</b>	<b>RATCHET WHEEL</b>	<b>BARREL AND TRAIN-WHEEL BRIDGE</b>
<b>Method</b>	<ol style="list-style-type: none"> <li>1) Lubricate tube for intermediate wheel rocker for alarm (Moebius Synt-A-Lube)</li> <li>2) Sufficiently lubricate alarm intermediate wheel (Moebius Synt-A-Lube)</li> <li>3) Set intermediate wheel rocker for alarm and its screw</li> <li>4) Set alarm ratchet wheel and alarm ratchet wheel screw (tighten screw by turning it to the left)</li> <li>5) Check winding process of alarm mainspring by turning crown (Crown can be reversed since hammer portion is not assembled)</li> </ol>	<ol style="list-style-type: none"> <li>1) Set click and click screw</li> <li>2) Set ratchet wheel, pawl lever seat, and ratchet wheel screw</li> <li>3) Check condition of train wheels</li> </ol>	<ol style="list-style-type: none"> <li>1) Lubricate alarm barrel arbor upper pivot (watch oil S-4 or Moebius grease "Remontoires")</li> <li>2) Set barrel and train-wheel bridge and its screws</li> <li>3) Sufficiently lubricate crown wheel and intermediate winding wheel axle (Moebius-Synt-A-Lube)</li> <li>4) Lubricate third wheel, sweep second wheel &amp; pinion, and escape wheel pivots (Moebius Synt-A-Lube)</li> </ol>
<b>Remark</b>			

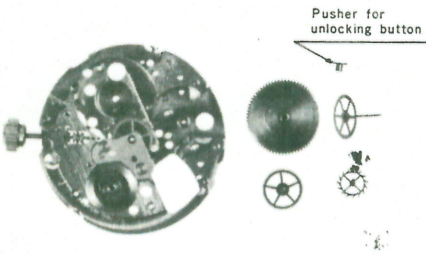
## 4006A Disassembly and assembly—continued

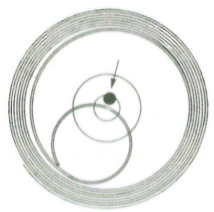
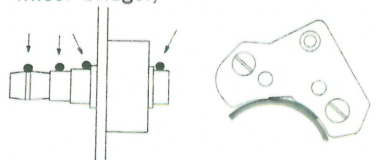
<b>Disassembly</b>	<b>26</b>	<b>TRAIN-WHEELS</b>	<b>27</b>
	<ol style="list-style-type: none"> <li>1) Remove escape wheel, sweep second wheel &amp; pinion, third wheel, and barrel</li> <li>2) Remove pusher for unlocking button</li> </ol>		<ol style="list-style-type: none"> <li>1) Remove alarm barrel arbor while holding alarm mainspring so that it does not project</li> </ol>
			<p>There is no need of removing alarm mainspring because it is self-greasing spring. (Spring assembled in plate does not project even when washed with ultrasonic cleaner.)</p>
<b>Method</b>			
<b>Remark</b>			
<b>Photo</b>			
<b>Assembly</b>	<b>5</b>	<b>TRAIN-WHEELS</b>	<b>4</b>
	<ol style="list-style-type: none"> <li>1) Lubricate barrel (Moebius grease "Remontoires" or S-4)</li> <li>2) Set barrel, third wheel, and escape wheel</li> <li>3) Lubricate sweep second portion of jewel for center wheel (Moebius Synt-A-Lube)</li> <li>4) Lubricate lower pivot of sweep second pinion with Moebius Synt-A-Lube</li> <li>5) Set sweep second wheel</li> <li>6) Lubricate pusher for unloking button (Moebius Synt-A-Lube)</li> <li>7) Set pusher for unlocking button, directing protruded portion inside</li> </ol>		<ol style="list-style-type: none"> <li>1) Lubricate pivot hole under alarm barrel arbor (Moebius grease "Remontoires")</li> <li>2) Set alarm barrel arbor</li> </ol>
			<p>When setting center wheel bridge, pay attention to contact portion with alarm mainspring. (Hold end of alarm mainspring to side of center wheel bridge.)</p>
<b>Method</b>			
<b>Remark</b>			

## 4006A Disassembly and assembly—continued

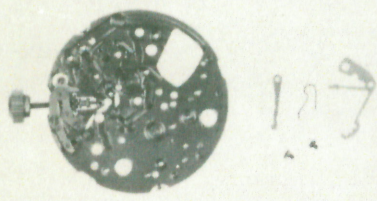
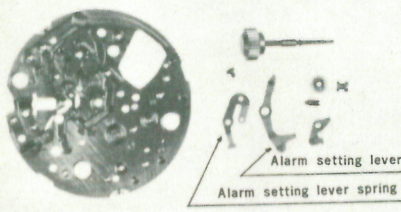
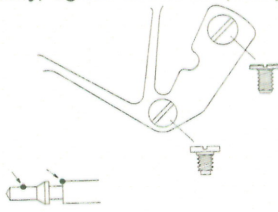
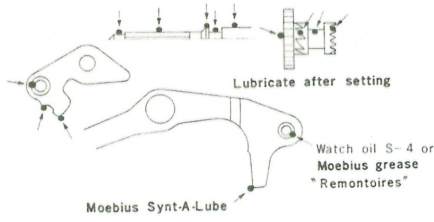
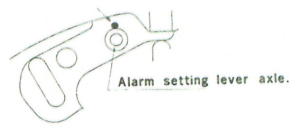

Disassembly	<b>29</b>	<b>YOKE</b>	<b>30</b>	
	<b>31</b>	<b>CLEANING</b>		
	<b>Method</b>	<ol style="list-style-type: none"> <li>1) Remove setting lever spring screws (2 pcs.)</li> <li>2) Remove setting lever spring</li> <li>3) Remove yoke spring</li> <li>4) Remove yoke</li> </ol>	<ol style="list-style-type: none"> <li>1) Remove alarm setting lever spring screw</li> <li>2) Remove alarm setting lever spring</li> <li>3) Remove alarm setting lever</li> <li>4) Remove setting lever</li> <li>5) Remove setting lever axle</li> <li>6) Remove winding stem, clutch wheel, and winding pinion</li> </ol>	<p>Check and clean all parts so far disassembled. (For further particulars see the item on Cleaning.)</p>
<b>Remark</b>				
<b>Photo</b>				
Assembly	<b>2</b>	<b>YOKE</b>	<b>1</b>	
	<b>Method</b>	<ol style="list-style-type: none"> <li>1) Set yoke</li> <li>2) Set yoke spring</li> <li>3) Set setting lever spring and its screws</li> <li>4) Lubricate the axle of the bell button (watch oil S-4 or Moebius grease "Remontoires")</li> <li>5) Set bell button (Button can be set by merely depressing it)</li> </ol>	<ol style="list-style-type: none"> <li>1) Lubricate winding stem, winding pinion, and clutch wheel with Moebius Synt-A-Lube, then set them to plate</li> <li>2) Set setting lever axle</li> <li>3) Lubricate setting lever with watch oil S-4 or Moebius Synt-A-Lube</li> <li>4) Lubricate alarm setting lever axle with watch oil S-4 or Moebius grease "Remontoires"</li> </ol>	<ol style="list-style-type: none"> <li>5) Lubricate alarm setting lever with watch oil S-4 and set it</li> <li>6) Set alarm setting lever spring</li> <li>7) Set alarm setting lever spring screw</li> </ol>
	<b>Remark</b>	<p>Generally, tighten screws completely.</p> 		 <p>Make head of alarm setting lever screw completely free from burr.</p>

# Oiling 4006A



## 1. Lubricating points and types of oil

- Refer to {
- Front train wheel.....Fig. 1
  - Setting mechanism .....Fig. 2
  - Automatic winding mechanism .....Fig. 3
  - Calendar and bell mechanism .....Fig. 4

### Oil to be used for this caliber

-  : Moebius Synt-A-Lube
-  : Seiko watch oil S-4
-  : Seiko watch oil S-2

### Oil quantity

-  : Extremely small quantity
-  : Normal quantity
-  : Sufficient quantity

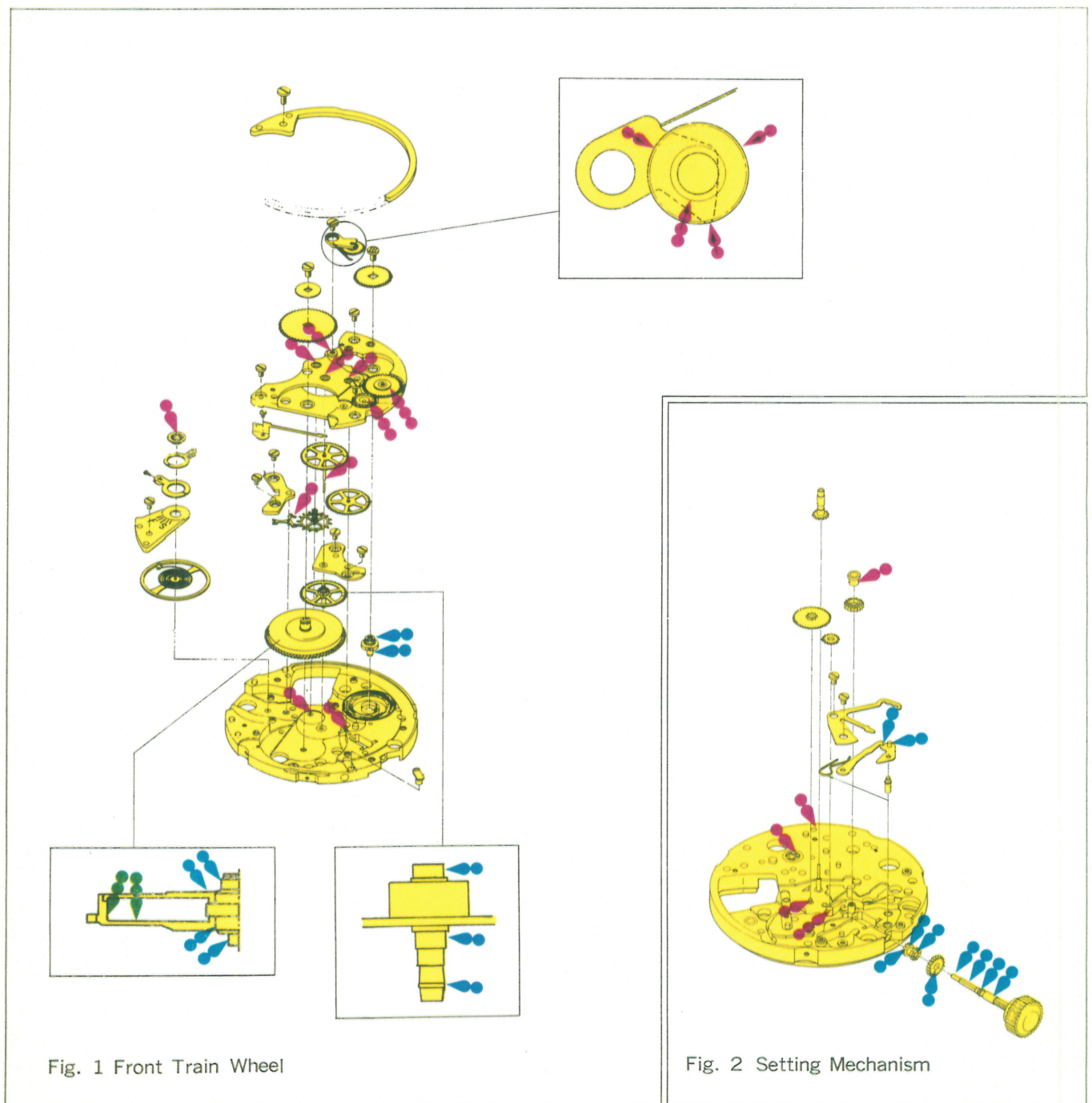

Lubricate the three ball bearings alternately.

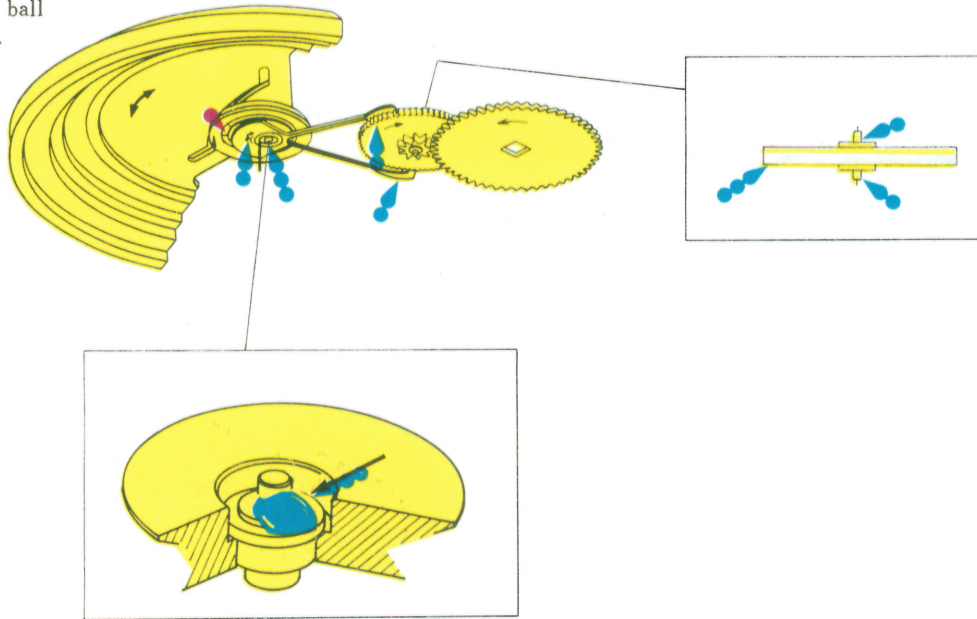

Fig. 3 Automatic Winding Mechanism

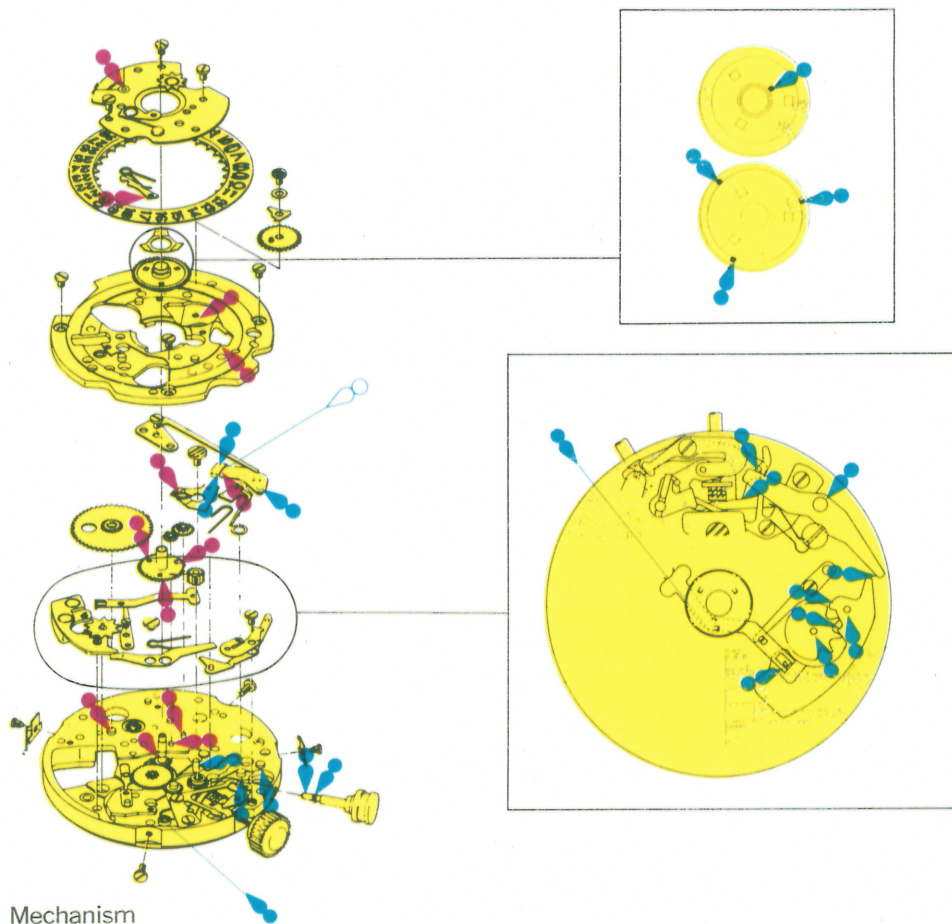

Fig. 4 Calendar and Bell Mechanism